

Copyright Notice

Copyright 2002-2009 Huper Laboratories. All Rights Reserved.

This document may not, in whole or in part, be reproduced or transmitted in any form or by electronic, mechanical, or optical means, including photocopying, recording, or storing in a retrieval system, or translated into any language in any form without the prior written consent of Huper Laboratories.

Warranties

Huper Laboratories makes no warranties with respect to this documentation and disclaims any implied warranties of merchantability and fitness for a particular purpose. Huper Laboratories shall not be liable for any error or for incidental or consequential damages in connection with the furnishing, performance, or use of this documentation or the examples herein. The information in this documentation is subject to change without notice.

Software License

The software described in the documentation is furnished under a User License Agreement that is included with the product. This Agreement specifies the permitted and prohibited uses of the product.

Trademarks

 and the **huperVision** logo are trademarks of Huper Laboratories. All other product names mentioned in this documentation are for identification purposes only and remain the sole property of their respective owners.



Table of Contents

Chapter 1: Introducing huperVision	1-1
Chapter 2: Site Server	2-1
Chapter 3: Record Player	3-1
Chapter 4: Backup Scheduler and Other Utilities	4-1
Chapter 5: huperRemote.....	5-1
Chapter 6: Remote Viewer	6-1
Chapter 7: Remote Record Player	7-1
Chapter 8: huperRemote PDA	8-1
Chapter 9: List Server	9-1
Appendix 1: How to Use the I/O Ports of a Video Capture Card	AP1-1
Appendix 2: Profile Settings of LiveTag.ini.....	AP2-1
Appendix 3: Guide to Connect PTZ Camera	AP3-1
Appendix 4: An Example of PTZ Custom Command Usage:	AP4-1
Appendix 5: IOC-0404P Card Guide.....	AP5-1
Appendix 6: IOB-0805 BOX Guide	AP6-1
Appendix 7: IOB-1616 BOX Guide.....	AP7-1
Appendix 8: LB-16 Input Video Loopback Card	AP8-1
Appendix 9: PTZ Camera Auto-tracking Guide	AP9-1
Appendix 10: ATI & Nvidia Dual-screen setting.....	AP10-1
Appendix 11: People Counter User Guide	AP11-1
Appendix 12: An Example of IP Camera (Video Server) Network Setting.....	AP12-1
Appendix 13: Face Detection.....	AP13-1
Appendix 14: Scene Change Detection.....	AP14-1
Appendix 15: Flame Detection Pro.....	AP15-1
Appendix 16: HV Settings Import Export.....	AP16-1
Appendix 17: Web Remote Player.....	AP17-1
Appendix 18: Privacy mask.....	AP18-1
Appendix 19: Web Remote Player 2.0.....	AP19-1
Appendix 20: SMTP settings.....	AP20-1
Appendix 21: MultipleView.....	AP21-1



Chapter 1

Introducing **huperVision**

The huperVision Surveillance System is the perfect security solution for the home and small businesses, as well as for large sites such as schools, airport terminals, office and condominium buildings, factories, and supermarkets. By installing the huperVision suite into the computer that is connected with surveillance cameras including IP cameras, motion sensors, and alarm devices and that will act as the DVR/Hybrid DVR/NVR server, you can monitor from this server both in- and outdoor premises, and record intruder break-ins, suspicious packages left on- scene, thefts, and any other abnormal activities on digital video. By using the client programs such as huperRemote, Remote Viewer or huperRemote PDA, you would also be able to monitor surveillance video from a remote computer or even a PDA.

The huperVision Surveillance System provides the following set of programs:

- **Site Server**

[Programs > huperVision > Site Server]

Site Server is the main surveillance and digital recording program. Its user interface allows live monitoring of up to 16 video cameras (such as CCTV, IP and PTZ video cameras) and 16 sensor units, and provides event detection/notification capabilities. You can set up Site Server to detect events using Motion detection, Sensor detection, Missing/left object detection, Virtual fence detection, Secure zone detection, etc. This program can also be configured to automatically record detected events, trigger alarms, and/or send notifications (such as sending e-mail, dialing out to a phone, etc.). You can have the same configuration options for all camera/sensor devices or specify different settings for each device. See " Chapter 2 Site Server" for details.

■ Record Player

[Programs > huperVision > Record Player]

Record Player allows you to search and view previously recorded surveillance video. You can search for video records by specifying the camera number or the type of event (such as Motion detection, Virtual fence detection, etc.). This innovative smart search and detection technology saves you much time in locating certain video recordings from a huge database.

■ Backup Scheduler

[Programs > huperVision > Backup Scheduler]

Backup Scheduler allows you to make backups of the recorded videos. You can initiate the backup process manually, or configure this program to perform automatic backup onto the specified storage locations. See "Chapter 4 Backup Server" for details.

■ huperRemote

[Programs > huperRemote > huperRemote]

huperRemote is a specially designed client software that allows users to view remote video cameras and record the video and audio from these cameras to the local computer. It also allows users to download and view video recordings from remote DVR servers. Other features include scheduled recording, remote PTZ camera control, weighted bandwidth assignment (for smoother viewing of remote cameras), two-way voice communication, and remote live sound broadcast. See "Chapter 5 huperRemote" for details.

■ Remote Viewer and Remote Record Player

[Programs > Remote Viewer HV > Remote Vier] and [Programs > Remote Viewer HV > Remote Record Player]

Remote Viewer allows live video surveillance and recording in a remote computer via a Web browser. Remote users that are granted sufficient rights will be able to monitor video cameras, control PTZ cameras, record events on digital video, and

play back recorded events, and talk to the DVR Site Server. See "Chapter 6 Remote Viewer" for details.

Whereas Remote Record Player allows you to download a video recording from a remote DVR server to your local computer, specify the date and time of the video recording to download after downloading, you can play back the video recording using this same program. See "Chapter 7 Remote Record Player" for details.

■ **huperRemote PDA**

huperRemote PDA is a client software that allows users to view remote video cameras and control remote PTZ cameras right on the PDA. See "Chapter 8 huperRemote PDA" for details.

■ **List Server**

List Server keeps track of the DVR servers that are connected on the network and maintains the user account database. This program runs in the background. See "Chapter 9 List Server" for details.

Features

Site Server

- **Multi-screen, High-Quality Video Display**
 - 1, 4, 6, 7, 9, 10, 13, and 16 split-screen layout.
 - Supports full-screen view.
 - Excellent video display quality without trailing or 'ghost' effect.
 - Adjustable brightness, contrast, saturation, and hue for a clearer camera picture.
 - Visibility enhancement impressively enhances dark/nighttime video for better viewing.
 - Sharpness adjustment increases readability of blurred text or sharpens blurred images on the camera video.
 - Noise reduction eliminates camera video noise, and also reduces noise in dark scenes or nighttime environment.
 - Supports digital zoom for magnifying the live camera view.
 - Caption display on the split screens.

- **Advanced Surveillance Features**
 - Supports the integration of traditional security sensors and devices.
 - Device control support I/O devices up to 16 sensor inputs and 16 relay outputs.
 - Features an electronic map that lays out the location of video cameras, sensors and alarm devices.
 - Advanced PTZ control functions include:
 - Adjustable iris level, focus, pan speed, and tilt speed
 - Auto-panning and auto-loop
 - A joystick or keyboard can be used to control the PTZ camera.
 - Direct PTZ Control for monitoring and controlling high-end smart dome PTZ cameras.
 - Converse with a colleague or security guard who's in another location using the Talk feature.
 - Responds to events by notification or by sending signals to external devices such as alarms.
 - Task scheduling for video recording, motion detection, and event notification.

- **Notification**
 - Capture image snapshots when an event is detected and send e-mail notification with image attachment. Time interval between snapshots can be set from 1 up to 5 seconds.
 - Event notification by phone, e-mail, fax, alarm, or flashing message.
 - Phone notification on video loss.
 - Trigger traditional alarm devices.
 - Auto-generate and send by e-mail reports that show information about detected events on a daily, weekly, or monthly basis.

- **Complete Digital Video and Audio Recording Features**
 - Uses industry standard Motion-JPEG compression when recording video. Also features Huper Laboratories' proprietary HM (MPEG4-like) compression that provides near loss-less video quality and saves a great deal of disk space.
 - Features automatic adjustment of compression ratios based on scene complexity, and achieves optimal quality and high compression ratio.
 - Supports up to D1 video resolution. Choose to record video in one of the following resolutions:
NTSC: 320x240, 640x240, 640x480, 640x480 HD, 720x240, 720x480, 720x480 HD
PAL: 320x240, 640x240, 640x480, 640x480 HD, 720x288, 720x576, 720x576 HD
 - Pre-event recording starts the video recording 1 up to 10 seconds prior to the time a detected event occurred.
 - Adjustable recording quality and frame rate for each video camera.
 - Types of video recording include non-stop recording, non-stop smart recording, event recording and time-lapse recording.
 - Record audio along with the video using a separate audio recording device for each camera.
 - Smart saving during recording. Site Server automatically determines the recording frame rate based on the amount of movement. Lower frame rate is used for static video, and higher frame rate for full motion video.

- **Object Tracking, Size Filtering, and Various Types of Detection Methods**
 - 8 methods of detecting events: Motion detection, Sensor detection, Manual trigger, Missing & left object detection, Virtual fence detection, Secure zone

detection, Flow counting, and Flame detection.

- Supports signal tolerance, sensitivity adjustment, and eliminates prompt motion to avoid false alarms.
 - Mask out insignificant areas to exclude them during detection.
 - Real-time object tracking of moving objects. Suspicious moving objects will be displayed with a bounding box to highlight them on the screen.
 - Size filtering allows insignificant moving objects to be ignored to reduce false alarms. The minimum and maximum size of objects to be filtered can be defined.
- **Stability and Productivity**
 - Hardware watchdog restarts the DVR server automatically when system errors occur.
 - Timer for auto-restarting the DVR server. Start-up time can be adjusted.
 - Allows multiple drive and folder locations to be used for storing video recordings.
 - Recycles hard drive storage to keep fixed days of video recordings.
 - Keeps a log of DVR server activities, including log-on and log-off sessions, configuration changes, motion event, alarm event, and more.
 - Keep the last 24 hours of events in the New Event Information log.
 - Double-click an entry in the event log to open the Event Player and view a recorded event.
 - **Networking and Security**
 - Local or centralized control of user account database.
 - Provides multiple levels of user ID and password protection.
 - Web server support allows users to remotely view/control video cameras and PTZ cameras via a Web browser (through the Internet or dial-up connection) or on mobile phones.
 - Dynamic IP server support allows DVR servers to be assigned with dynamic IP addresses. Users can view Webcam pages by choosing the site name at the Dynamic IP Server. All sites posted at the Dynamic IP Server are protected by ID and password.
 - Video server support allows real-time video and audio streaming for users to remotely play back video recordings.

Record Player

- Video recordings are played in the original video size by default.
- Zoom in during playback of video recordings.
- Calendar highlights the dates that have video recordings.
- Locate a video recording by specific date and camera.
- Search through a video recording by time or type of event. 4 types of events: motion events, missing & left object events, sensor events, or manually triggered events.
- Smart search allows you to search only for motion changes, missing objects, or unattended/suspicious objects on the video recording:
 - Create profiles that contain your custom-defined settings for detecting motion or static objects.
 - Mask out insignificant areas to exclude them during detection.
 - Real-time object tracking of moving objects. Suspicious moving objects will be displayed with a bounding box to highlight them on the screen.
 - Size filtering allows insignificant moving objects to be ignored to reduce false alarms. The minimum and maximum size of objects to be filtered can be defined.
- Use thumbnail or list mode to display search results.
- Save a part of the video recording to an AVI or self-executable file. The self-executable file is embedded with digital watermark and password for authentication and protection.
- Capture images from a video recording and print or save.

Backup Scheduler

- Select video cameras and perform manual backup of video recordings.
- Specify a preset schedule for performing automatic back-up of video recordings.
- Back-up database records event information.

huperRemote

- Multi-screen, High-Quality Video Display
 - Two program window sizes are available for the user interface: 1024x768 and 800x600. You can choose the proper window size according to the display resolution you have set for your monitor display.

- Flexible split-screen display allows you to resize split screens and change their positions on the user interface easily.

- Remote Monitoring and Recording
 - Connect to remote sites by the DVR site name or by camera groups.
 - Always display live video from all remote cameras, or display the camera video only when events have been detected. Audio from the remote cameras can also be enabled.
 - Display at most 16 remote cameras from different DVR sites through your Internet connection. Display camera video in full-screen, 1/4/9/16 split-screen, or in loop mode.
 - Meaningful icons are provided for you to easily identify PTZ cameras, CCTV cameras, event recordings, continuous recordings, local recordings, and more.
 - Manually trigger an event to a remote DVR server to issue an immediate warning in the event of an intrusion or abnormal situation.
 - Directly control remote PTZ/DOME cameras.
 - Allocate full bandwidth to a specific camera on-the-fly to increase the display frame rate.
 - Notify events by alarm sound.
 - Remote desktop control. Remotely modify settings of remote DVR servers.
 - Event-only mode displays only remote cameras when there is an abnormal event taking place.
 - Real-time, full-duplex (two-way) voice communication for instant event handling. Transmit voice and remotely receive live audio from the server sites.
 - Live video and audio recording. Provides two recording modes: Non-stop recording and Event recording.
 - Scheduled recording: daily or weekly basis.
 - Recycle storage to either keep fixed days of video recordings on the local drive or to free up disk space when hard disk space is almost full.

- Scheduler
 - Set up specific day and time schedules for continuous recording of surveillance video from remote cameras on your local drive.
 - Batch download video recordings.

- Playback of Surveillance Recordings
 - Retrieve history records from a remote DVR site, and download or stream surveillance recordings for playback on your local computer.
 - Retrieve history records from a remote DVR site, and download or stream surveillance recordings for playback on your local computer.
 - View at most 16 recordings simultaneously. Playback speed can be adjusted from 1/8X speed to 128X speed.
 - Download remote video recordings in batches.
 - A Calendar window on the user interface clearly indicates which days of the month have surveillance recordings.
 - Take a snapshot of video frames, then print them or save them in BMP or JPEG format.

Remote Viewer

- Supports Internet or modem dial-up connection.
- 1, 4, 9, and 16 split-screen layout and full-screen view on a Web browser.
- Connect to multiple cameras from different DVR servers.
- Control the DVR server desktop remotely.
- Allows remote configuration of multiple DVR servers over the Internet.
- Remotely control video cameras and PTZ cameras.
- Record surveillance video from remote cameras into the local hard drive.
- Preview live sound from remote video cameras over the Internet.
- Two-way voice communication between the DVR Server and client.
- Dynamic IP server support allows remote users to query the DVR server's IP address through the Internet.
- Capture an image snapshot during playback and print the image.

Remote Record Player

- Download video recordings from a DVR server and play back on a local computer.
- Zoom in or out while playing the downloaded recording.

List Server

- Keeps track of all DVR servers and provides centralized management of the user account database.

Applications

- Monitoring the babies room, a sick family member or the elderly.
- Home and community security: Notify security personnel in time by telephone when there is an intrusion. Remote monitoring is also supported.
- Store or supermarket surveillance: Monitor whether or not there are unauthorized people trespassing your warehouse through 24-hour or month-long recording.
- Office surveillance: Monitor entrance and exit to keep track of who goes in and out of your office.
- Automated bank machine and teller counter surveillance.
- Department store surveillance: Monitor showcase counters, display counters, and visiting customers.
- Remote monitoring of each floor in a building. Centralize the monitored records in a secure place through LAN.
- Monitoring server rooms and factory machines for easier tracking of abnormal situations.
- Traffic flow
- Checking airport terminals for suspicious luggage that are left behind.
- Monitoring stores and shopping malls for theft and shoplifting.
- Building and security checkpoint monitoring
- Inventory monitoring in warehouses.
- Manufacturing process monitoring in industry sites
- Fire control.
- And much...

Note: The stability of the DVR system may be affected by the type or brand of motherboard and chipsets used.

Chapter 2

Site Server

Site Server is a digital video and audio surveillance and recording program. It allows up to 16 video cameras, 16 audio input devices, and 16 sensors to be monitored simultaneously on the program screen. For each camera, the motion detection feature and other methods of detection can be activated for tracking and recording suspicious events. For the utmost security, round-the-clock, non-stop video recording can also be enabled. As the administrator of your huperVision Surveillance System, you can also create accounts for other users and give them access rights to Site Server and the other programs of your huperVision system.

Launching the Site Server

Everytime you start your computer, Site Server automatically runs by itself. By default, Site Server will allow any user to have access to the program. To restrict the program's access rights only to the local Administrator account, click  to open the Preferences dialog box, then click the User tab and select the "Enable access control" option.

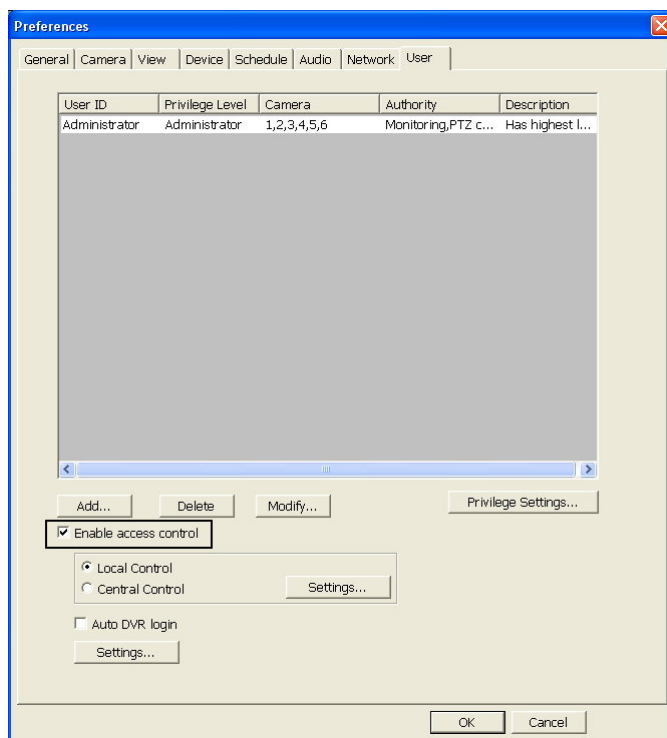

A message box then appears, informing you that there is no password yet for the local Administrator account. Click OK.



The Modify User dialog box then opens. Enter the desired password twice in the Password and Confirm password text boxes, then click OK.

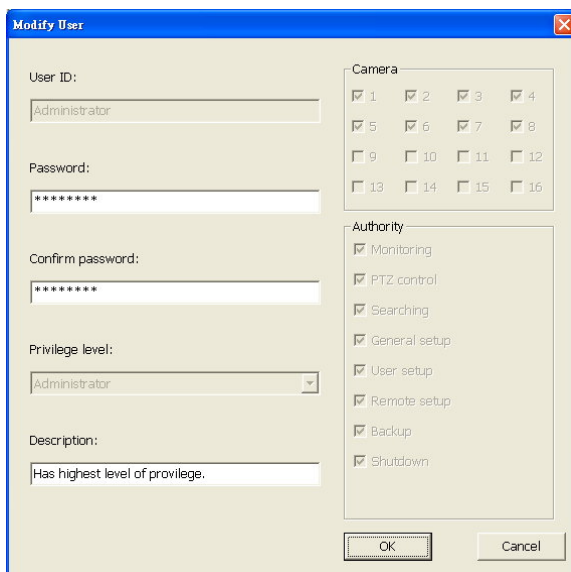

When access control is enabled, Site Server will, by default, run in logoff mode when the program is launched. When Site Server is in logoff mode, the split screens on the program window will not show any surveillance video and will appear as gray frames.

To logon to Site Server and have access to all of its functions, click . A pop-up menu then opens. Click Log In on the pop-up menu. The Site Server Login dialog box then opens. Type "Administrator" and the password in the "User ID" and "Password" text boxes, then

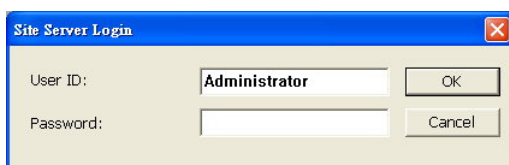

Notes:

- You can add more user accounts to Site Server. (See "Creating and maintaining user accounts".)
- If there are several computers installed with Site Server and connected via LAN, use the List Server program to manage and monitor the different Site Server systems. (See Chapter 9 for more information on the List Server.)

Introducing the Site Server Interface

When you have entered or logged into the Site Server program, the program goes into Live mode. In this mode, you will be able to see live video from up to 16 cameras and monitor input/output devices (such as sensors and alarms).

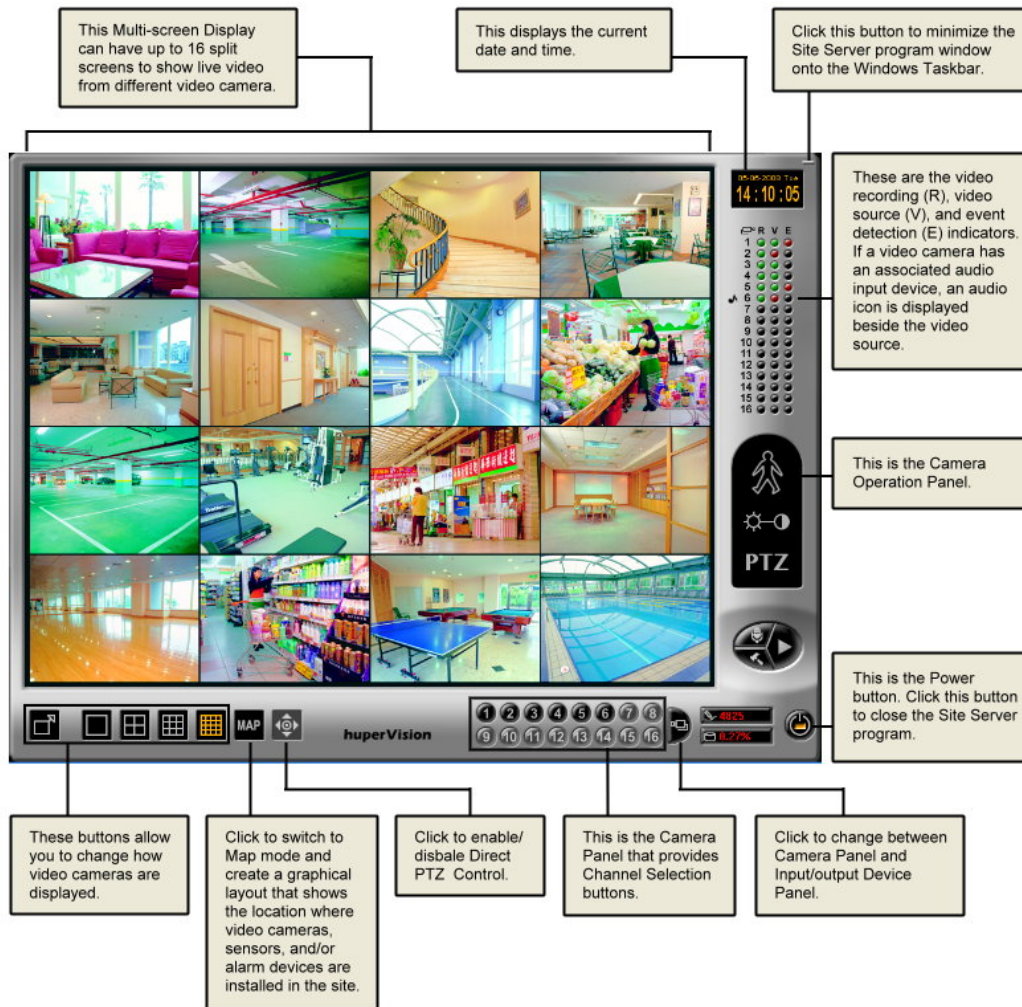

Split Screen buttons

These buttons set how many split screens are displayed on the program screen.

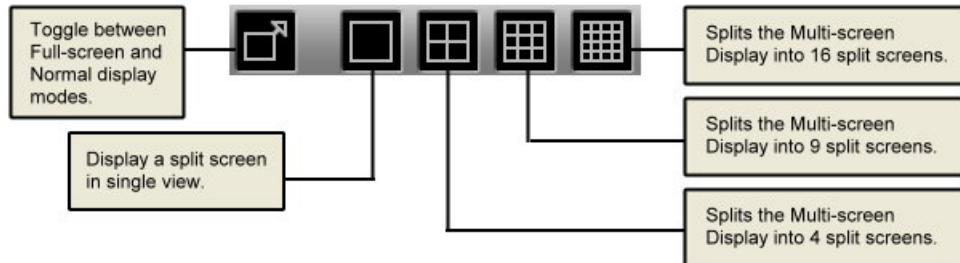

When you click the Full Screen button  to change Site Server into Full Screen mode, only video windows will be shown and the user interface controls will be hidden. To make the user interface controls appear, press [ESC] or move the mouse near the lower side or the right side of the screen.

If Full Screen mode will be used, it is recommended to hide the Windows taskbar to prevent it from covering the user interface controls.

Split Screens

Split screens show live video from the video cameras that are installed in the monitored site. On the split screens, the video camera number, current date and time, etc. can be displayed. If video recording is currently in progress, a "REC" indicator will also appear at the bottom right corner of the corresponding screen.



Note: Per split screen, the "REC" indicator will be displayed if and only if the caption display is enabled in the Preferences dialog box: Camera tab and when the respective cameras are in video recording mode. (See "Configuring caption display settings".)

Maximizing split screen size

If there are multiple split screens displayed, double-click a split screen if you want to maximize its size and temporarily cover its three neighboring screens. How a split screen is maximized depends on the total number of split screens that are currently displayed on the Site Server program window. For instance, if there are 9 split screens displayed, double-clicking Camera 1 will enlarge it to occupy half of the program window; double-clicking Camera 1 again will further enlarge it to occupy the entire program screen.

To restore a split screen back to its previous size, double-click on it again.

To restore enlarged split screens back to their normal size, right-click any of the split screens, then select Reset Layout from the pop-up menu.

Changing split screen position

Drag a split screen and drop it to another split screen to exchange their positions.

Map button

Click the Map button to switch Site Server to Map mode. This mode shows a graphical layout of the site being monitored, with clear indications on where the video cameras, sensors, and/or alarms are installed. (See "Monitoring a Site in Map Mode" for details.)

Channel Selection Panel

By default, Video Camera buttons are displayed at the bottom of the Site Server program window. These buttons allow you to display a split screen in single view.

If there are input/output devices such as sensors and alarms also connected, you can easily switch between viewing video cameras and monitoring the input/output devices.

Camera Panel

This panel provides camera buttons that are numbered in sequence and a Switcher button.



Input/Output Device Panel

Input/Output Device Panel displays the status of connected sensors, alarms and other traditional security devices.

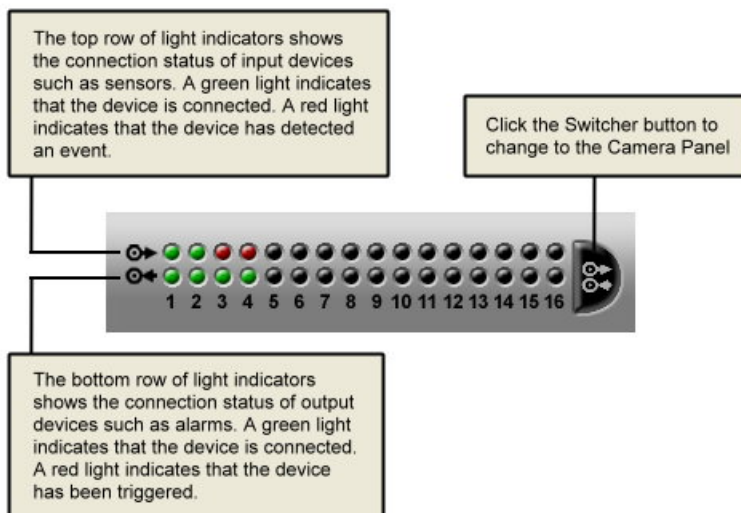

Status Panel

The Status Panel displays four types of status information: Video Recording, Video Signal, Audio Connection Icon, and Event Signal.

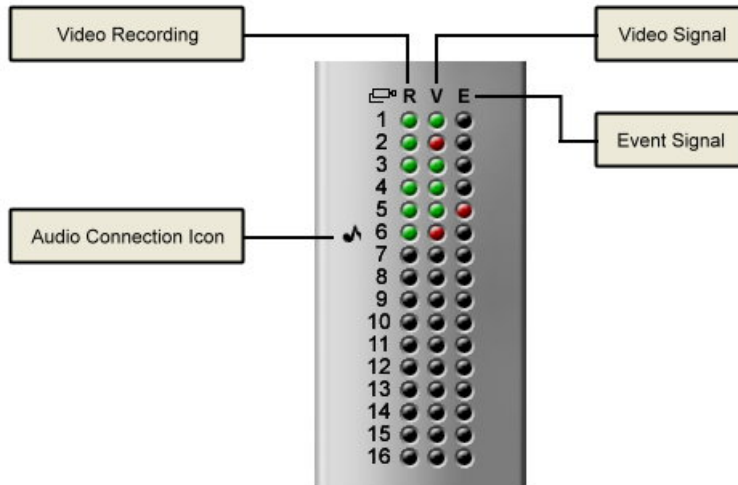

Video Recording

"R" stands for video recording. When a light indicator appears green in color, it means that the video recording function is enabled for the video camera.

Video Signal

"V" stands for video signal from cameras. When a light indicator appears green in color, it means that the video camera is connected and turned on. When a light indicator appears red in color, it means that connection to the video camera is lost.

Event Signal

"E" stands for event signal, which could have been activated by motion detection or by an input device such as the sensor. The light indicator appears red in color when an event has been detected.

Note: Video/Audio recording features, video camera connections, audio channel connections, and input device connections can all be enabled or disabled in the Preferences dialog box. (Refer to the section "Configuring the Site Server" for details.)

Camera Operation Panel

The Camera Operation Panel allows you to switch between three different control panels: Motion Detection Panel, Camera Adjustment Panel, and PTZ Camera Control Panel.

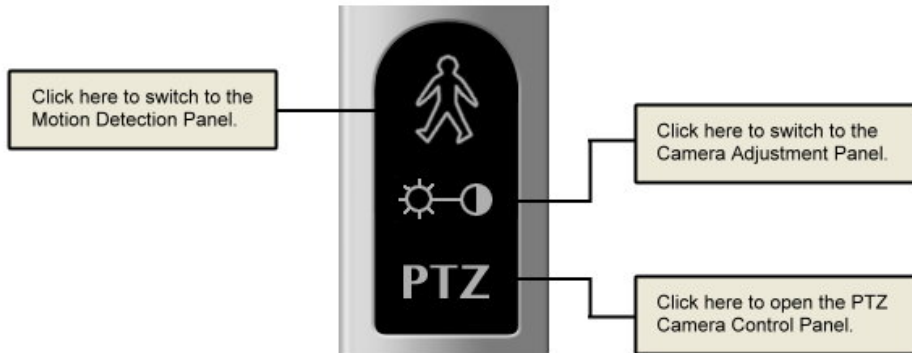

Motion Detection Panel

The Motion Detection Panel allows you to manually start or stop motion detection. The Start and Stop buttons are available only when the current camera's motion detection function has not been configured to be performed on a scheduled basis.

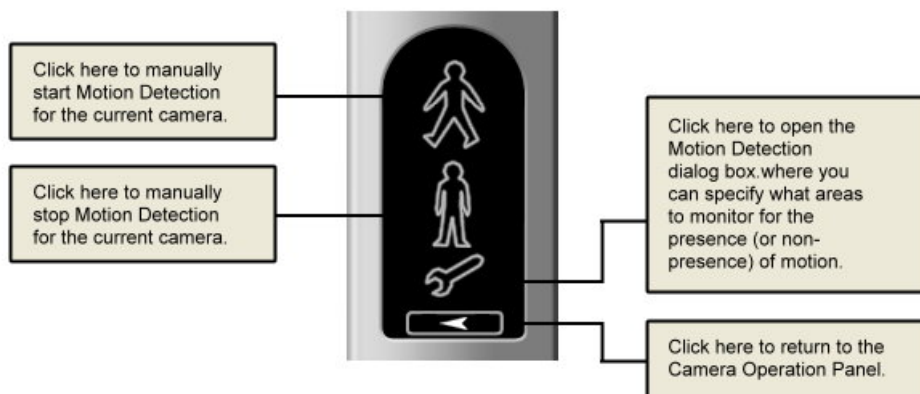

Note: Motion detection cannot be stopped if the recording method is set to Non-stop smart recording.

Camera Adjustment Panel

The Camera Adjustment Panel provides controls for adjusting the hue color, saturation, brightness, and contrast of the camera video.

Brightness and Contrast Panel

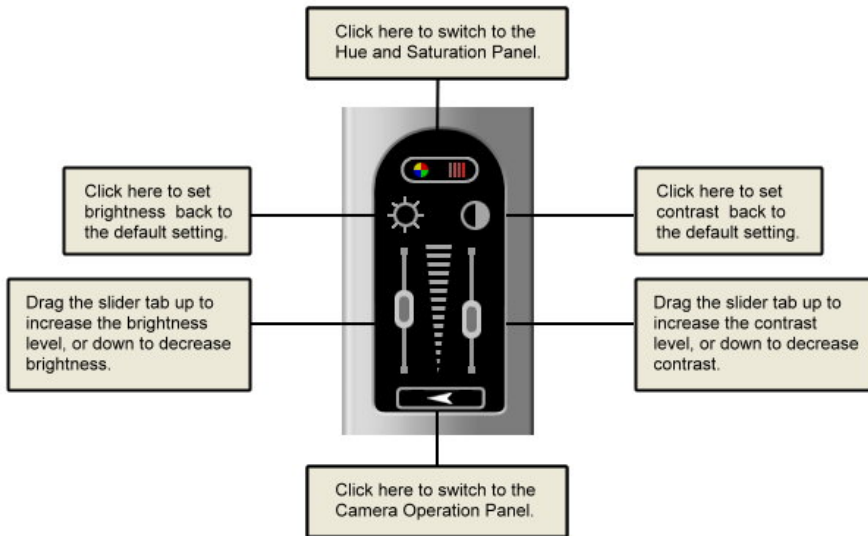

Hue and Saturation Panel

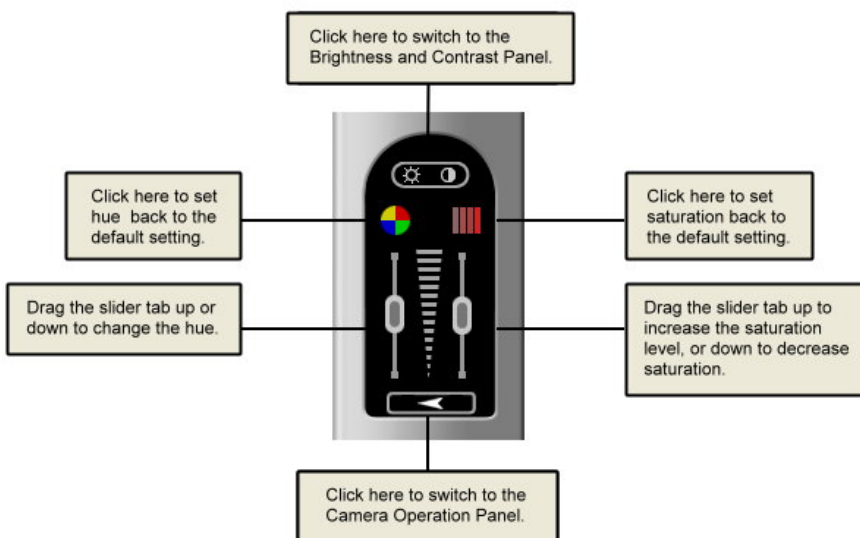

Note: Hue adjustment is not available on PAL video cameras.

Other button controls

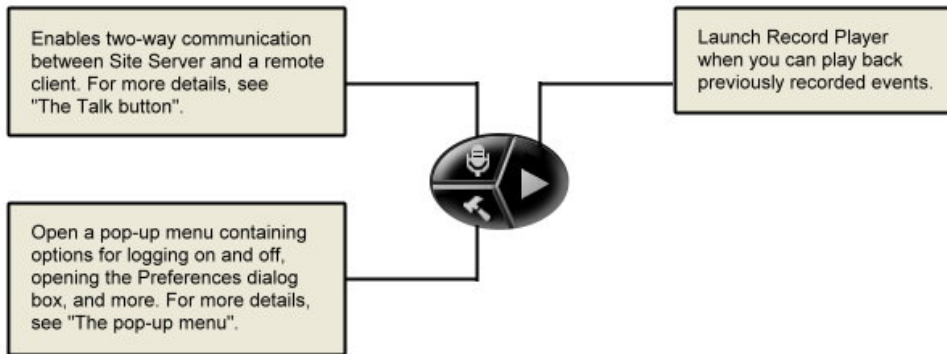

The pop-up menu

Clicking the  button opens the following pop-up menu:



- | | |
|------------------|--|
| Log In / Out | Allows you to log on or off the Site Server. |
| Operation Log | Opens a dialog box where you can see a list of operations that are logged by the Site Server. For more details, see "Viewing logs and disk usage information" in this chapter. |
| Backup Scheduler | Launches Backup Scheduler where you can manually do a backup of video records or schedule a daily backup. For more information, see Chapter 4. |
| Preferences | Opens the Preferences dialog box where you can customize surveillance video recording, smart detection, and more. |
| About | Opens the About dialog box where you can see copyright and version information about huperVision. |

The Talk Button

Site Server can be enabled to accept two-way communication request from a remote client site also running the Remote Viewer program. Click the Talk button to open the Talk dialog box where you can configure settings to enable two-way voice communication.

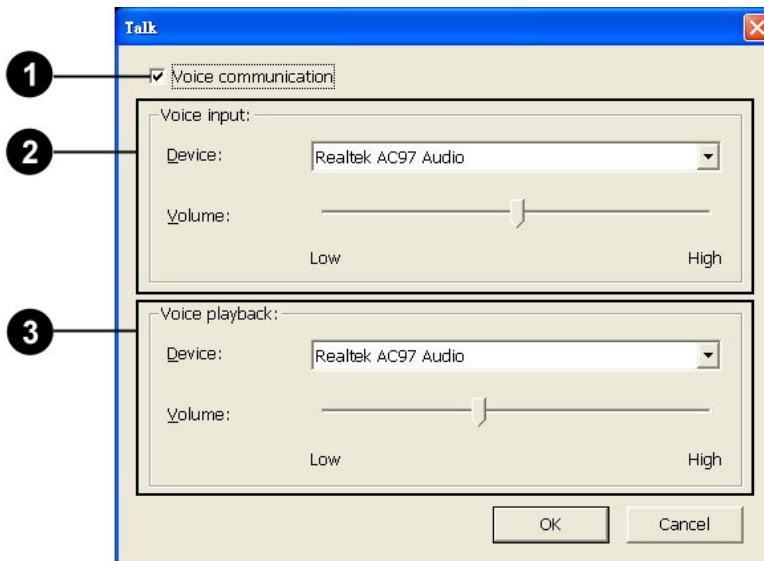

- 1** Voice communication Select this option to activate the Talk feature of Site Server.
- 2** Voice input Displays the audio device used by your input device (e.g. microphone) to capture your voice. You can also adjust the input device's volume here. If you have more than one audio device installed, select the device you want to use from the drop-down menu.
- 3** Voice playback Displays the audio device used by your playback device (e.g. speakers) to play back the voice from your counterpart. You can also adjust the playback device's volume here. If you have more than one audio device installed, select the device you want to use from the drop-down menu.

The Voice input and Voice playback audio devices that you select must not be occupied by another device when using the Talk feature. Please check the Audio tab in Preferences to see if the audio device is being used or not. See "Audio capturing device settings (Audio tab)" for details.

Operating PTZ Cameras

Use the PTZ Camera Control Panel to operate PTZ (Pan/Tilt/Zoom) cameras.

PTZ Control Panel

The PTZ Camera Control Panel provides four types of adjustment panels that allow you to customize and operate PTZ cameras. Click  to open a pop-up menu where you can switch between these four panels.

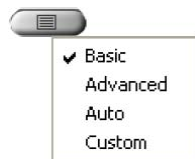

- | | |
|----------|--|
| Basic | Switch to the Basic panel if you want to manually control camera panning, tilt movements, and zooming. |
| Advanced | The Advanced panel allows you to set the iris level and focus of a selected PTZ camera as well as the camera's pan and tilt speed. |
| Auto | Switch to the Auto panel if you want to enable/disable the auto-panning or auto-loop function. In this panel, you can define settings for these functions. |
| Custom | The Custom panel lists commands for operating the PTZ camera that you have custom-defined in the Settings dialog |

Basic

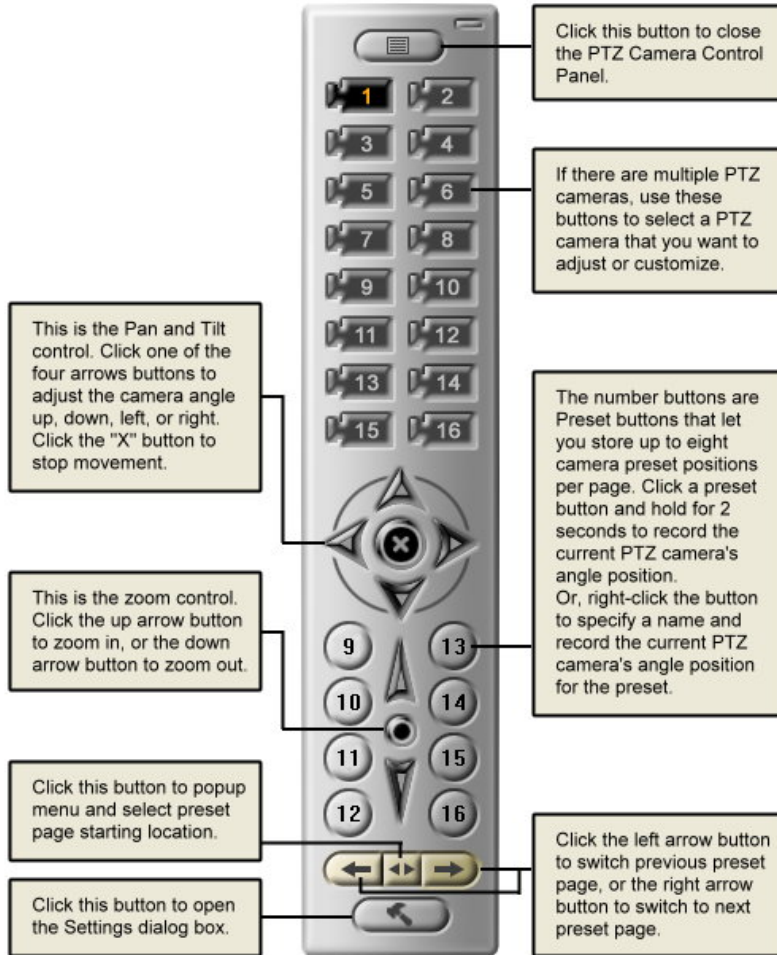

Advanced

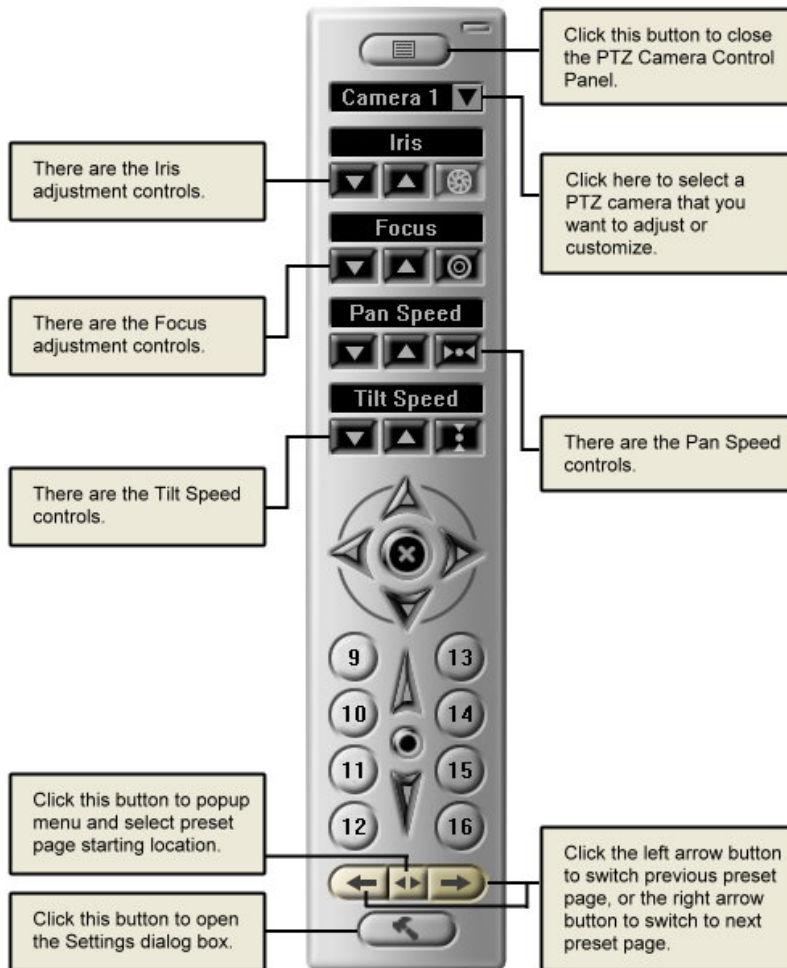

Iris controls

The iris lens of a PTZ camera controls the amount of light that enters the camera. These are the Iris adjustment controls:



Focus controls

Use the Focus controls to set the focus distance.

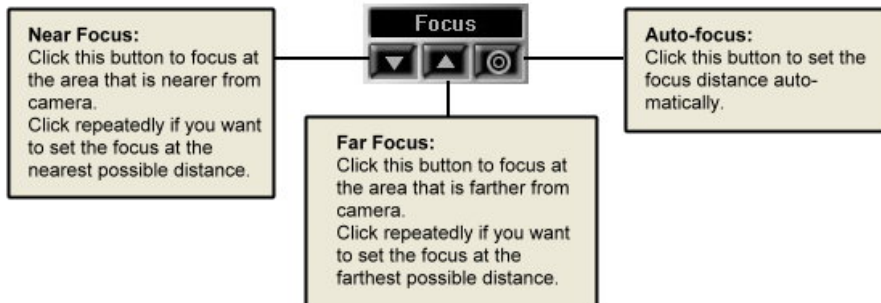

Pan Speed controls

Use the Pan Speed controls to set the speed for turning the PTZ camera.

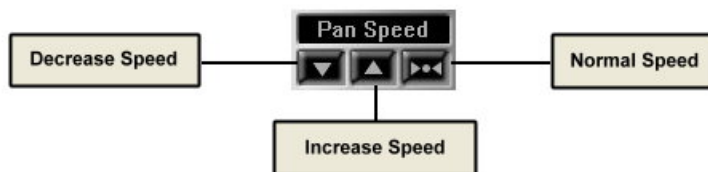

Tilt Speed controls

Use the Tilt Speed controls to set the speed for adjusting the angle of the PTZ camera.

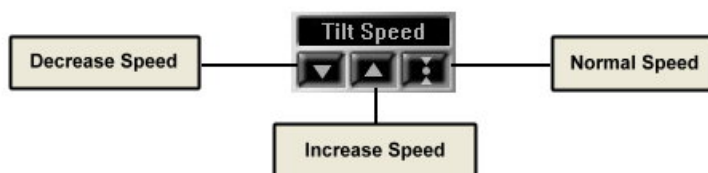

Auto

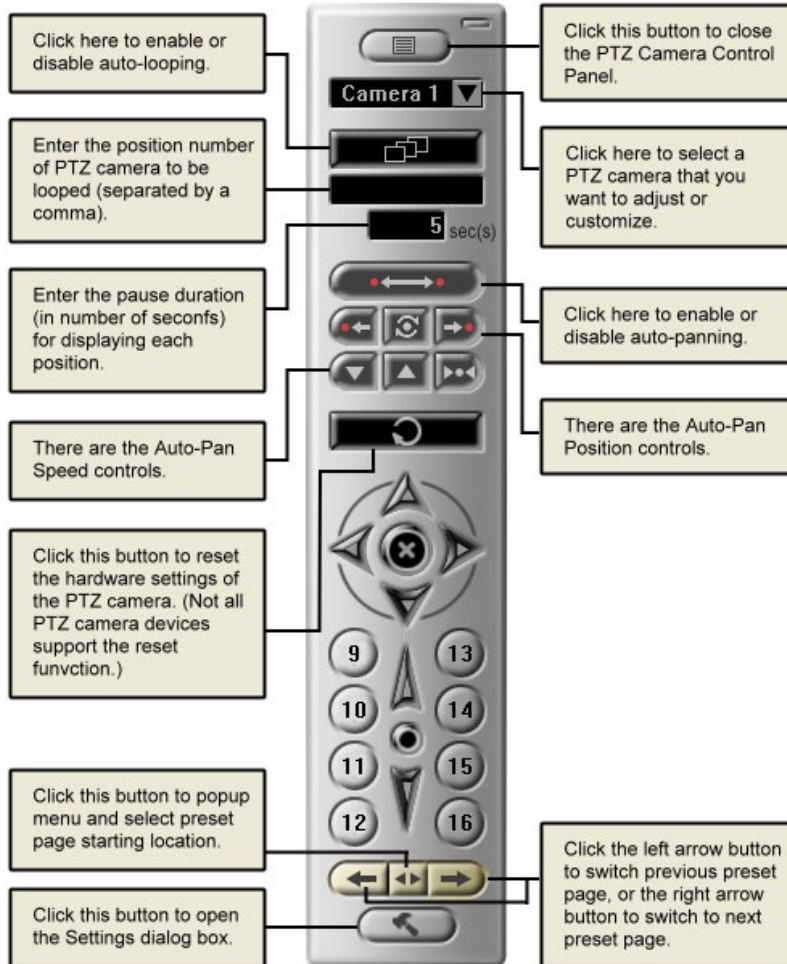

Auto-Pan Position controls

Use these buttons to set the two camera positions for auto-panning.

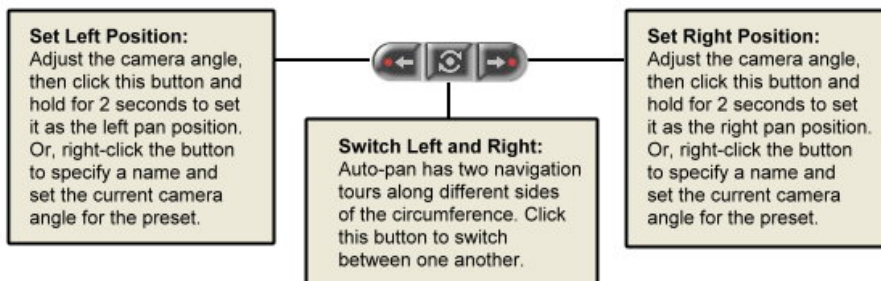

Auto-Pan Speed controls

Use these buttons to set the speed for auto-panning the PTZ camera.

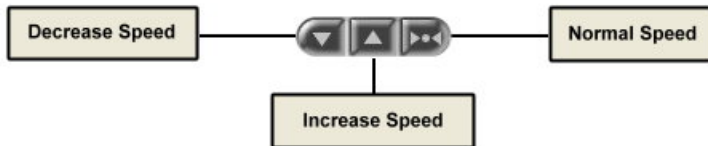

Custom

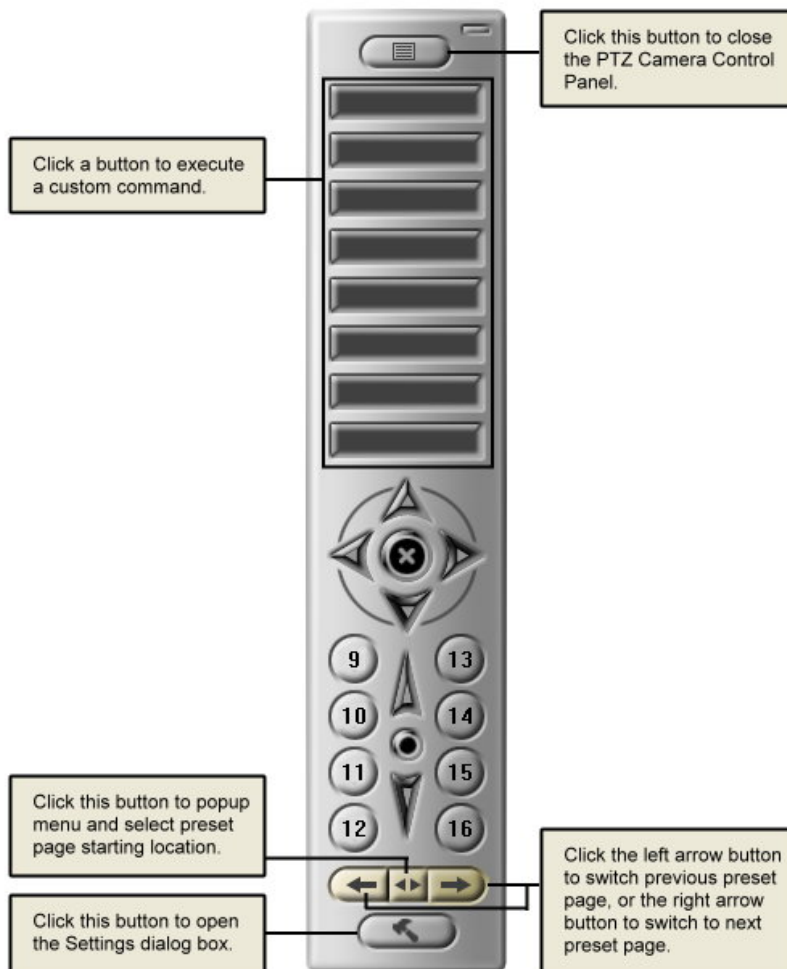

Settings dialog box

The Settings dialog box allows you to activate/deactivate PTZ cameras and define advanced settings for these cameras.

PTZ Device

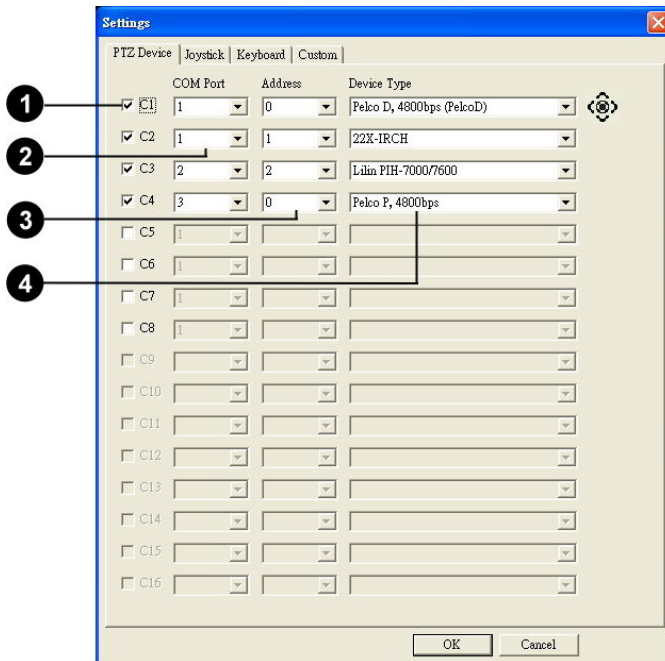

- 1** Video Input Ports (C1 - C16)

These indicate the total number of video input ports that are available in your capture card. For instance, if C1 to C4 are enabled and the remaining numbers are grayed out, this means that your capture card is only equipped with 4 video input ports.

If you have PTZ cameras, you need to select which video input ports of the capture card the cameras' video cables are plugged into. If you select the incorrect check boxes, you will not have access to the PTZ cameras.

- 2** COM Port

Select the proper COM port on the Site Server computer where a PTZ camera's control cable is connected to.

- 3** Address

If there are multiple interconnected PTZ cameras that share the same COM port, specify each PTZ camera's address ID. Note: The address ID is set on the PTZ camera device, and must be unique for each device.

- 4** Device Type

Select the brand/model name of the PTZ camera.

Joystick Device

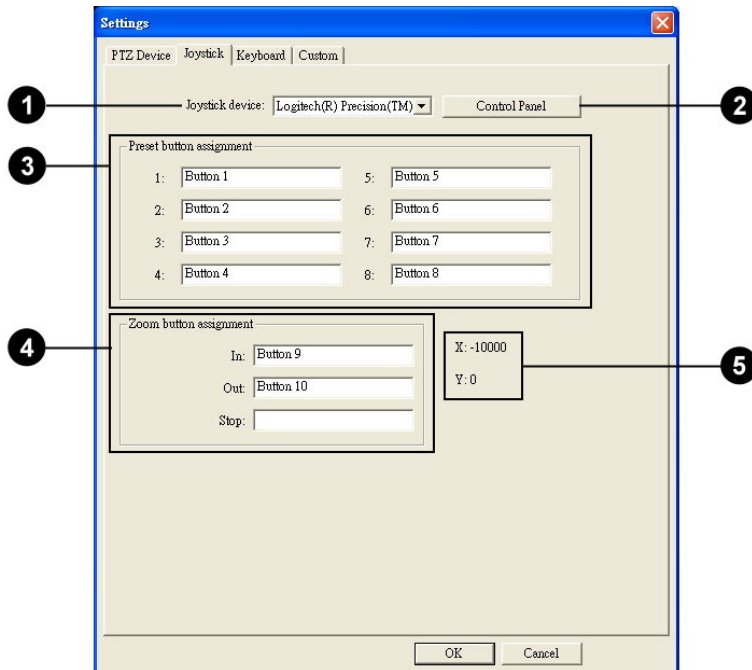

- 1** Joystick device If the computer is installed with a joystick device, you can use the joystick to control a PTZ camera. Select the joystick device from this drop-down list to customize it
- 2** Control Panel Click this button to open a Control Panel where you can test the selected joystick device.
- 3** Preset button assignment The numbers in this group box represent the eight preset camera angle positions. You can assign different joystick buttons to each of these preset positions.
- 4** Zoom button assignment Here, you can assign different joystick buttons for zooming in, zooming out, and pausing camera zoom.
- 5** X: Y: Displays the current coordinate position of the joystick movement.

Keyboard

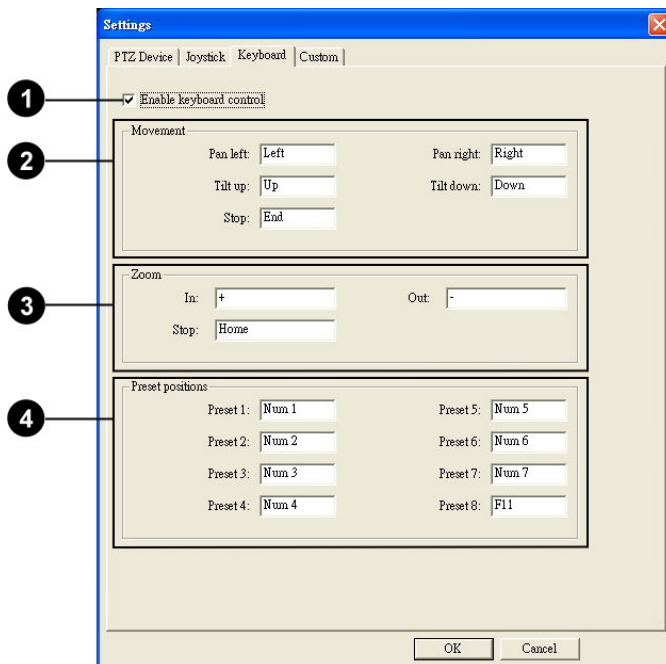

- 1** Enable keyboard operation

Select this option if you want to operate the PTZ camera through a keyboard.
- 2** Movement

Assign the desired keys to use for controlling camera movement such as pan, tilt, and pause. To assign, first click your mouse inside the text box, then press the desired key. For instance, if you want Pan Left to be assigned with the Left Arrow key, simply press this key in the provided text box.
- 3** Zoom

Assign the desired keys to use for zooming in, zooming out, and pausing camera zoom. Simply press the key you want to assign in the provided text box.
- 4** Preset positions

The preset numbers in this group box represent the eight preset camera angle positions. You can assign a different key to each of these preset positions by simply pressing the desired key in the provided text box.

Custom

This is where you can customize the buttons in the Custom panel and assign PTZ commands to each button. You can define up to eight buttons.

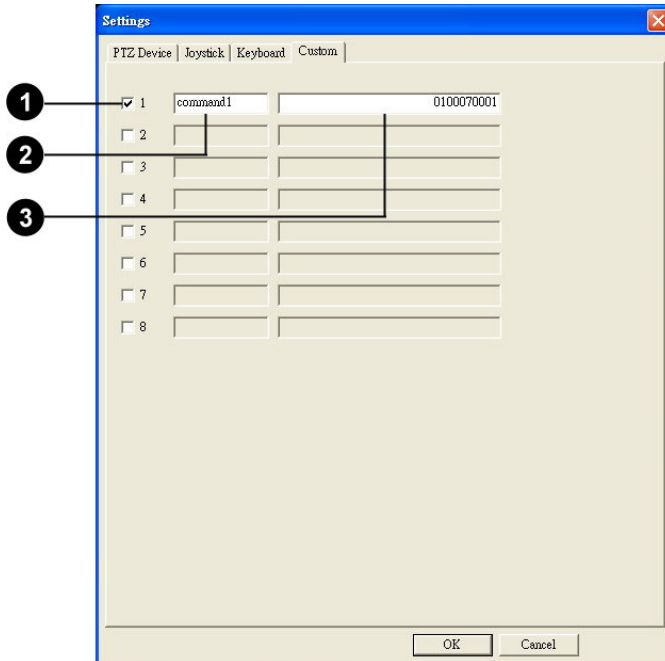

- 1** Button number Select a number to customize a button.
- 2** Button name Specify a descriptive name for each button, which will appear on the Custom panel.
- 3** Command Enter the custom command in the provided text box. PTZ control commands are hexadecimal strings, and different PTZ camera manufacturers provide different sets of control commands. You can get the control command list from the PTZ camera manufacturer or download from the manufacturer's Web site.

Direct PTZ Control



The Direct PTZ Control allows you to adjust camera angle position and zoom ratio on the video screen directly. Click the  button to enable/disable the On-screen PTZ Control mode. Before operating a PTZ camera, click a PTZ camera split screen to select it first.



Basic Operation

Basic operation is available to all PTZ cameras.

Pan/tilt Movement

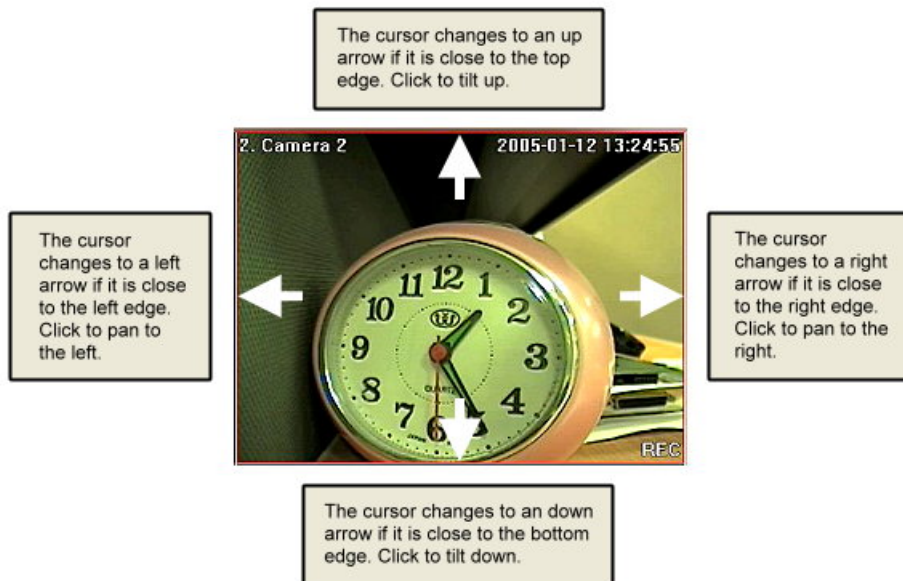

Wheel Zoom

Scroll the mouse wheel forward/backward to zoom in/out the PTZ camera.

Advanced Operation

Advanced operation is available to some advanced PTZ cameras.

Click to Move

When you click a position on the PTZ camera video screen, the PTZ camera adjusts its angle position automatically and moves the clicked position to the center of the camera video screen.

Note: Because of the mechanical limitation of pan and tilt angle range, the clicked position might not be right at the center of the camera video screen.

Drag to Move and Zoom

When you click and drag your mouse over an area on the PTZ camera video screen, the PTZ camera adjusts its angle position automatically and moves that area to the center of camera video screen, and then zooms in the area.

Note:

- Advanced operation is available to the following dome cameras:
 - Dynacolor dome camera
www.dynacolor.com.tw/english
Model: 7725
 - Pelco dome camera Spectra III.
www.pelco.com
Model: Spectra III SE and Spectra III series
- If the dome camera supports advanced operation, an icon  will be displayed right beside its settings in the Preferences dialog box - PTZ Device tab.

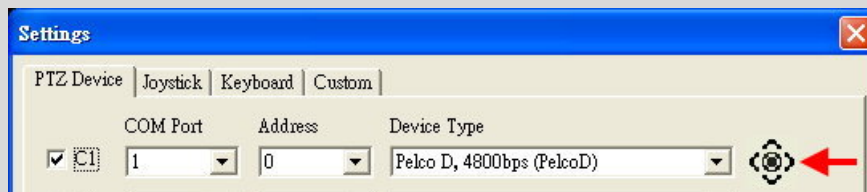



Auto-tracking

Auto-tracking is an innovative functionality that enables PTZ cameras to track moving objects on live video. Right-click on a split screen, then on the pop-up menu that opens, click PTZ Auto Tracking. This opens the Auto-tracking dialog box where you can set up how to track moving objects.

For more information about how to set up auto-tracking, see Appendix 9.

Monitoring a Site in Map Mode



To create a graphical layout of the site being monitored, switch to Map mode. Map mode allows you to load a picture of the entire site being monitored and insert device icons on the picture to indicate the locations where video cameras, sensors, and/or alarm devices are installed in the site. This can help you to instantly identify the location where detected events occurred and take immediate actions when necessary.

To switch to Map mode, click . Then, click  to switch to Map Edit mode and start creating a map layout of the monitored site.

Creating a site map

To create a map layout in Map Edit mode, place the camera, sensor, and output device icons on the site map according to their actual installed locations. See the figure next page for step- by-step instructions.

While you are adding camera icons onto the map, you may notice that their colors vary. Camera icons may appear in one of these three colors:

-  In gray color, indicates that there is no video camera connected.
-  In light blue color, indicates that there is a video camera connected but the corresponding camera icon has not yet been plotted on the site map.
-  In dark blue color, indicates that there is a video camera connected and the corresponding camera icon has already been plotted on the site map.

While positioning an icon, you can remove an icon from the map by dragging that icon out of the map.

If you want to start all over and add icons to the map, click . This clears all icons from the map.

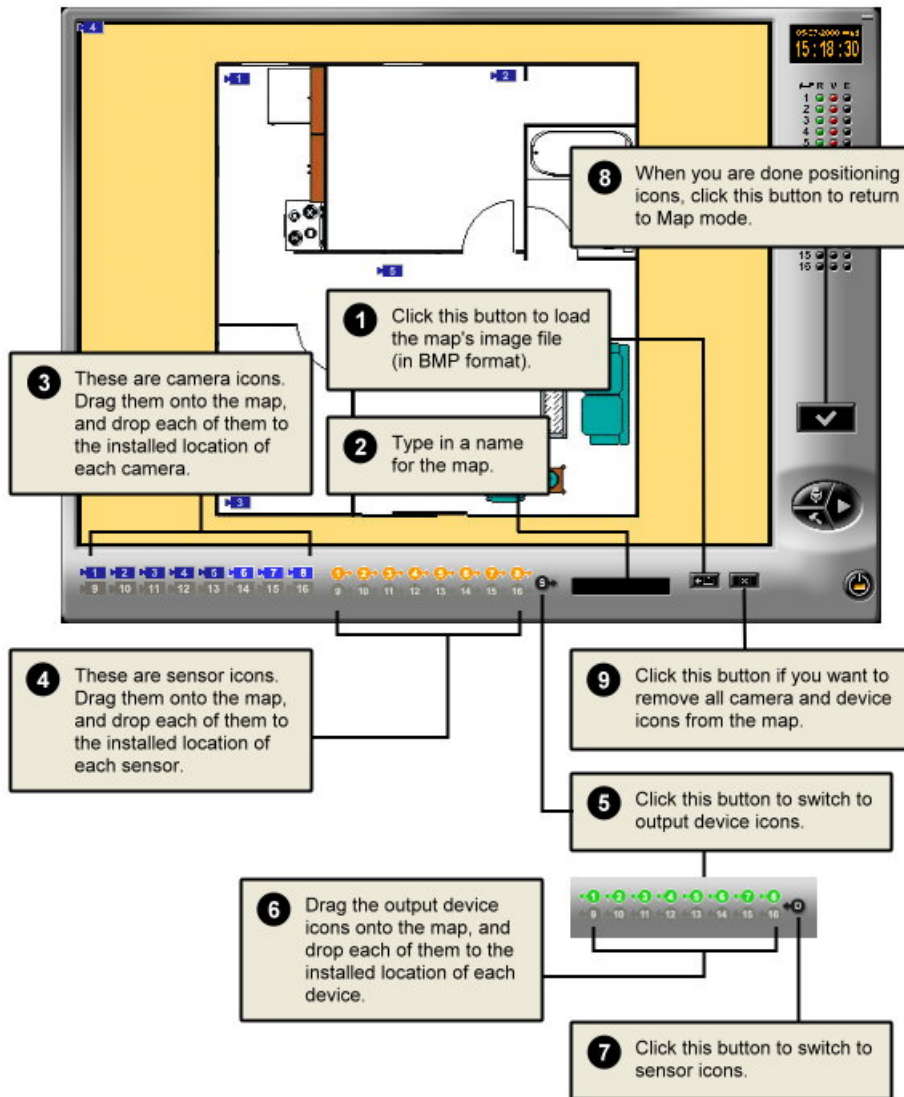

Viewing the site map

Once the site map is complete, you will be able to easily pinpoint locations where detected events occurred by watching out for flashing icons on the site map.

Whether it is a video camera, sensor or output device that has been triggered by an event, its corresponding icon on the map flashes. You can double-click on the camera icon to switch to single view and see what is happening live at the site.

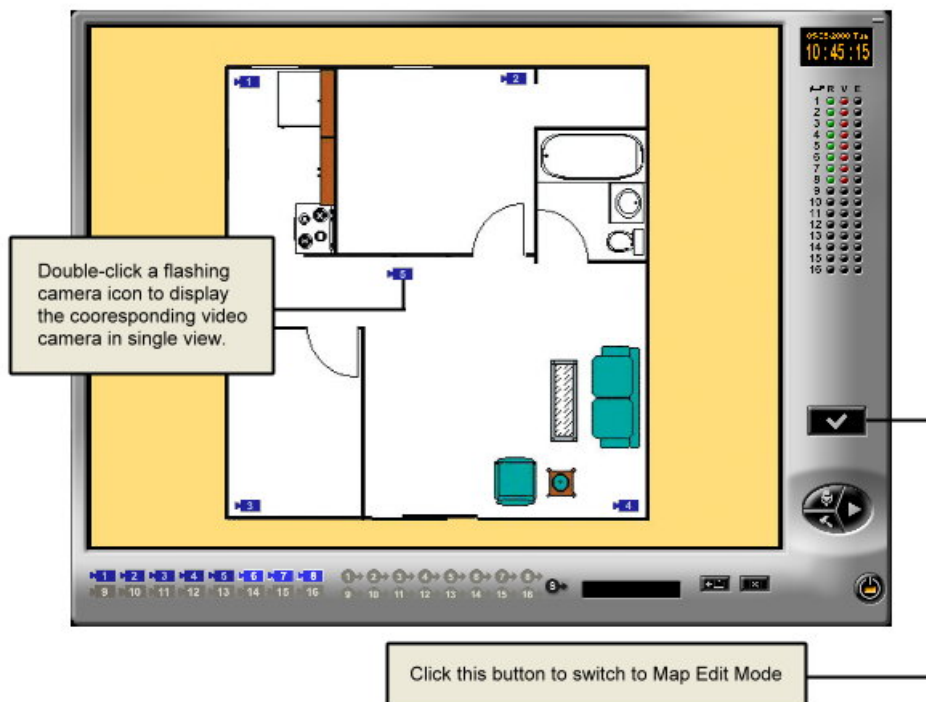

Configuring the Site Server

Click  on the Site Server program to open the Preferences dialog box and choose which video cameras and sensors to monitor, enable/disable output devices (such as alarms), and set up Site Server to perform motion detection, digital video recording, scheduled surveillance, and other tasks.

The succeeding sections explain how to configure settings in the Preferences dialog box.

General settings (General tab)

Click the General tab in the Preferences dialog box to configure the following settings:

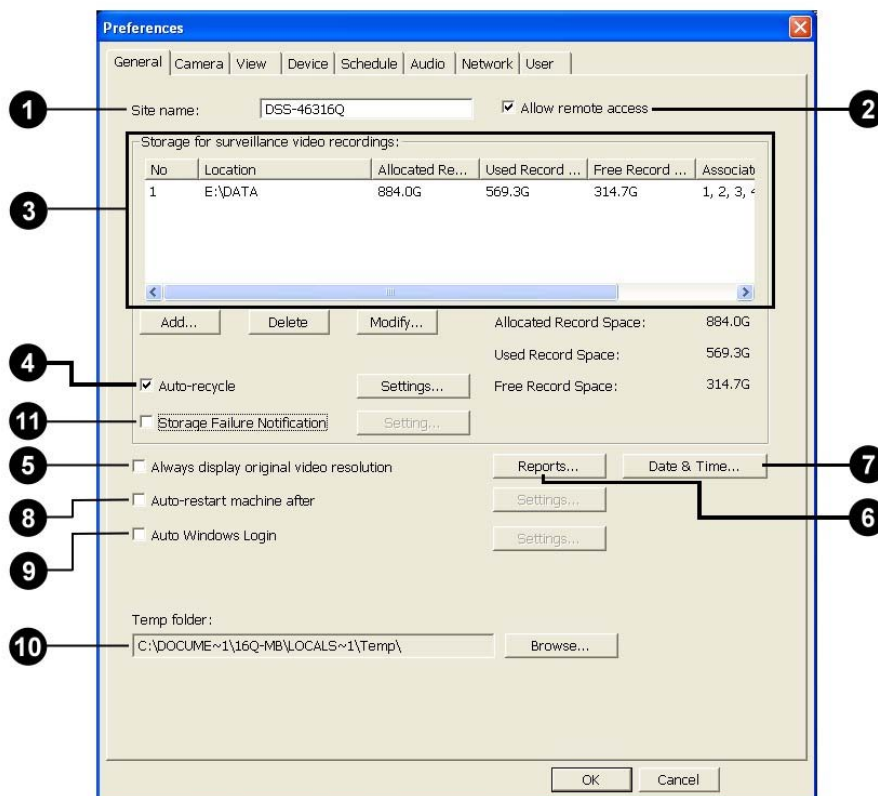

1 Site name

Type in a name for identifying the monitored site (for instance, the location name).

2 Allow remote access

Select this option if you want to enable other users to remotely monitor the site from Internet, Intranet or direct modem connection.

3 Storage for surveillance video recordings

Allocate disk drives and folders for saving digitally recorded videos.

4 Auto-recycle

Select this option to automatically delete old recordings to free up disk space. See "Auto recycling disk storage space" for details.

5 Always display original video resolution

Select this option if you want to speed up the video display.

6 Reports

Generate and e-mail reports about detected events periodically - in a daily, weekly, or monthly basis. (See "Scheduling reports" for more details.)

7 Date & Time

Specify the current date and time.

8 Auto-restart machine after

Select this option to enable the Site Server computer to be restarted after a specified length of time.

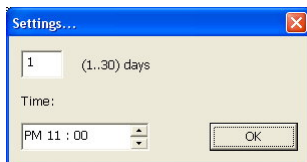

Click Settings to specify the number of days to elapse as well as the startup time.

9 Auto Windows Login

Select this option to log into Windows automatically when the DVR server is booted or restarted. To be able to do so, you need to click Settings and specify the valid user name and password as well as the domain name for login.

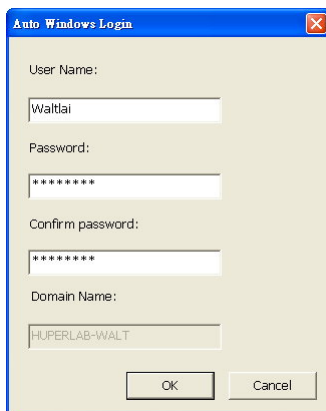

10 Temp folder

This folder stores temporary files generated by the Windows system and the Site Server program. You can use the default folder, or click Browse to choose another folder.

11 Storage Failure Notification

When this function is enabled, it will have notification while video recordings fail to write into storage.

This notification provides E-mail, Phone call, PC Speaker, Alarm sound and Output device alarms.

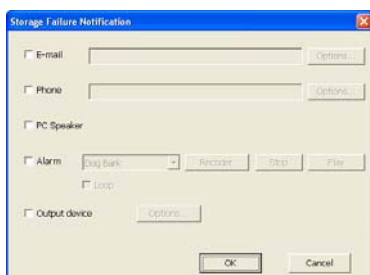

Assigning disk storage

To digitally record live video, disk storage needs to be allocated for saving the recordings.

To assign disk storage for storing video recordings:

1. Create a "Data" folder at each hard drive where your video recordings will be stored.
2. Click  to open the "Preferences" dialog box.
3. Click the General tab.
4. Click the Add button to open the Add Storage dialog box. (See "Add Storage dialog box" on the next page.)
5. Click the Browse button to select the "Data" folder of a hard drive.
6. Click the OK button to close the Add Storage dialog box.
7. The assigned hard drive and its data folder will then be displayed under the Storage for surveillance video recordings list.
8. Repeat steps 4 to 6 to add more data folders to be used for storing video recordings.
9. Click the OK button in the Preferences dialog box to confirm and use the modified settings.

Add Storage dialog box

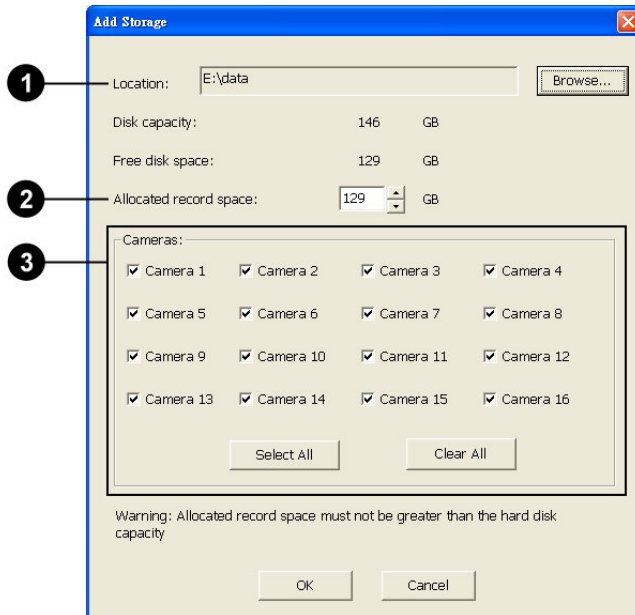

- 1** Location Specify the folder location to use for saving recordings. To choose a folder, click Browse.
 Note: A root folder cannot be used to save recordings. Please create a subfolder inside the root folder.
- 2** Allocated record space Specify the amount of disk space to allocate to the selected folder. If you add a folder that is not in the storage list and it contains previous video recordings, the default maximum record space is the total file size of the video recordings inside the selected folder.
- 3** Cameras Select the checkboxes of the cameras whose recordings you want to save to the selected folder. Click the Select All button to select all checkboxes. Click the Clear All button to deselect all checkboxes first before selecting the desired checkboxes.

Modify Storage dialog box

To change the assignments of a folder, click on its item number, then click Modify and make your changes in the Modify Storage dialog box.

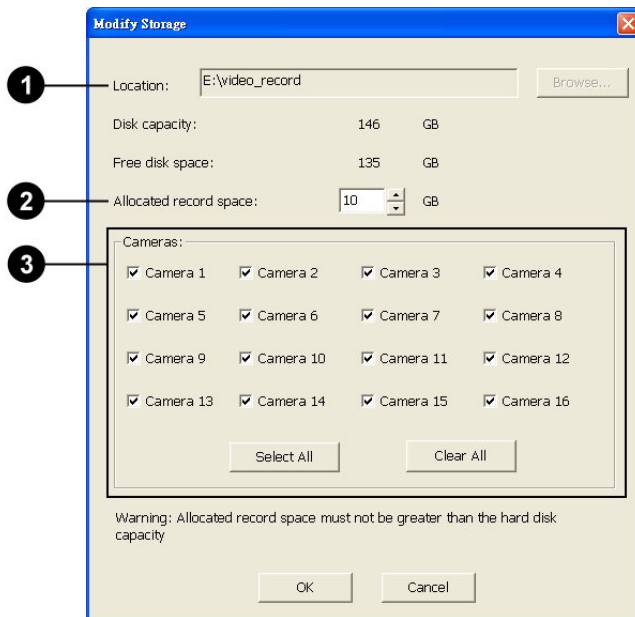

- 1** Location The folder location cannot be changed. (The only way to change the folder is to delete it and add a new folder.)
- 2** Allocated record space The allocated disk space can be increased or decreased.
- 3** Cameras Camera assignments can be changed by selecting/deselecting checkboxes.

Auto recycling disk storage space

Allocate as much disk space as necessary for saving digital recordings, but take note that video files are large in size and may eat up disk space fast. When the "Auto-recycle" option is selected, Site Server deletes old recordings and frees up disk space for reuse. Click the Settings button to open the Recycle Settings dialog box and specify how to recycle used disk space.

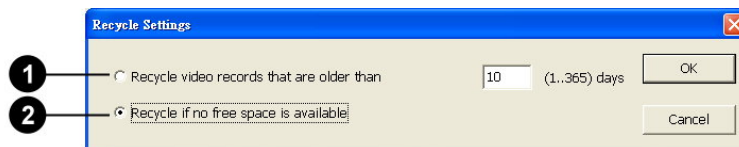

- 1** Recycle video records that are older than Select this option to automatically delete video records that are older than the specified number of days and use the freed storage for saving new recordings. Enter the number of days to retain before deleting old video records. It can be from 1 to 365 days.

- 2** Recycle if no free space are available Select this option to automatically recycle disk storage when there is no more free space in the assigned storages for saving new recordings.
A single recycling instance can free up 100MB for your record storage.

Always display original video resolution

In some split screen layouts, videos may not appear in their original video dimensions and may be scaled to fit into the split screens. Scaling is handled generally by the VGA display card's hardware acceleration feature. If the VGA card does not support scaling, Windows resizes the video size through software scaling.

However, software scaling uses more CPU power and is slower as compared to hardware scaling. To speed up the display of video images using VGA cards that don't have scaling capabilities, disable scaling by selecting the "Always display original video resolution" option. This is how Site Server displays video when this option is selected:

- When displaying a single split screen in full-screen view, video screen resolution will be changed to 640x480. You must press [ESC] to switch back to normal split-screen mode.
- When displaying 4 split screens in full-screen view, the whole screen resolution will be changed to 640x480 and each of the four split screens will be displayed in 320x240 resolution. You must press [ESC] to switch back to normal split-screen mode.
- When displaying 9 split screens in full-screen view, keep the video screen resolution in 1024x768 and display each camera window in 320x240. This keeps the 9 split screens close to each other and displays black borders between them. The 9 split screens occupy a 960x720 space at the center of the display screen.

Setting the date and time

If the system's date and time are not configured correctly, click the Date & Time button to make proper adjustments. This is crucial for Site Server to accurately record the date and time.

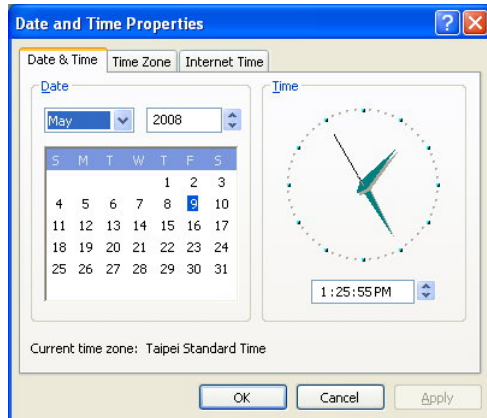

Scheduling reports

Site Server can send by e-mail periodic reports that show information about detected events. Click the Reports button to specify what types of events to include in the reports and to whom the reports will be sent.

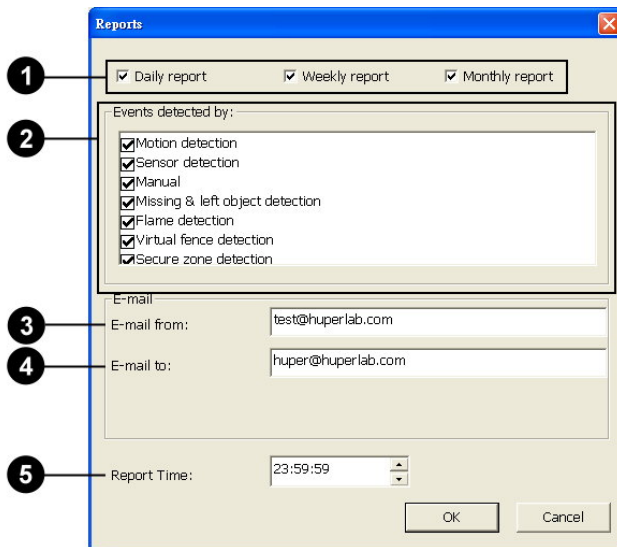

- | | |
|--|--|
| <p>1 Daily/Weekly/Monthly report</p> <p>2 Events detected by</p> <p>3 E-mail from</p> <p>4 E-mail to</p> <p>5 Report Time</p> | <p>Choose whether to send reports on a daily, weekly, or monthly basis.</p> <p>Select which events to include in the reports (that is, events which have been detected by the different methods of event detection such as Motion detection, Missing & left object detection, Sensor detection, Manual trigger, etc.).</p> <p>Specify the sender's e-mail address.</p> <p>Specify the recipient's e-mail address. If there are multiple recipients, separate each of their e-mail addresses with a semicolon.</p> <p>Choose the time of day when to send the report.</p> |
|--|--|

Video camera settings (Camera tab)

Click the Camera tab in the Preferences dialog box to configure settings for up to 16 video cameras. Each camera is identified by a camera number (C1 to C16). Click each camera button to set up options for a video camera.



In each group box under the Camera tab, there is an Apply To button. Click this button if you want the same settings in a group box to be applied to other video cameras as well. The Camera Selection dialog box will open where you can choose the video cameras to which the group box settings will be applied.

Note: The settings and masks you specified in smart detection methods cannot be applied to multiple selected cameras since each camera has a different video scene.

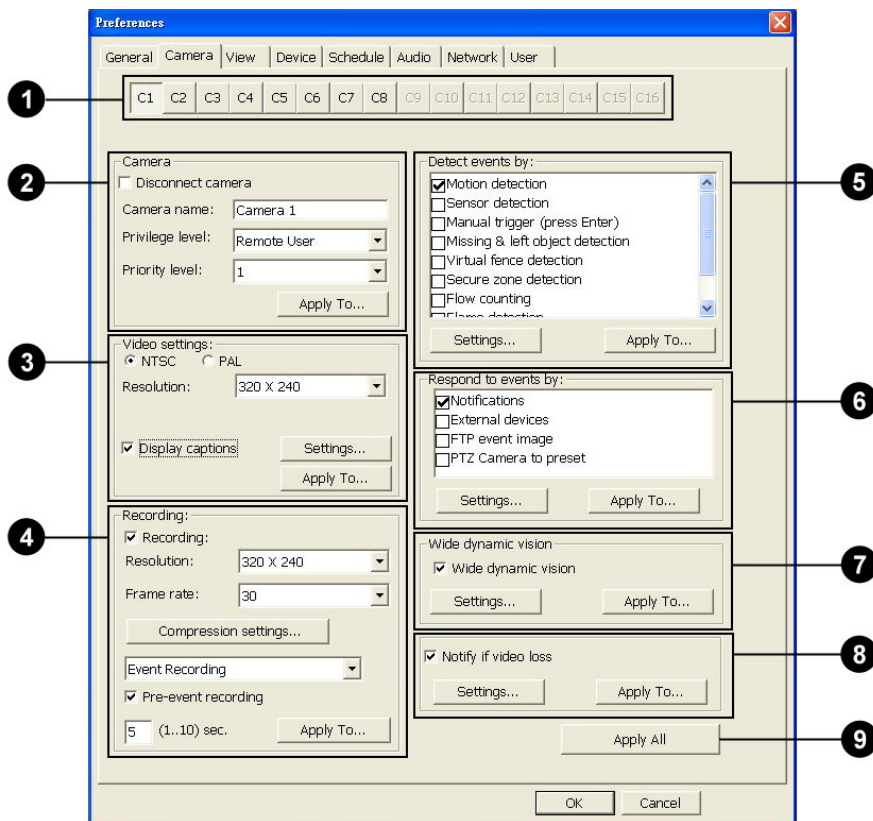

- 1** Camera buttons Each button corresponds to a video camera. Click a button to configure settings for a video camera.
- 2** Camera This group box provides general camera settings.
 - Disconnect camera Select this option to disable the connection to a camera and stop all tasks. Clear this option to re-establish camera connection.
 - Camera name Type in a name for identifying a video camera (for instance, the location where the camera is installed).
 - Privilege level Assign each camera with a privilege level to restrict unauthorized users from viewing the camera. (Refer to the section "User Accounts (User tab)" for details on the different privilege levels.)
 - Priority level The priority level determines which video camera will be given the highest priority and displayed in single view when multiple simultaneous events have been detected from several cameras. The range for priority level is from 1 to 16, level 1 being the highest priority.
- 3** Video settings This group box provides video display settings.
 - Resolution Choose the desired video resolution and video standard (NTSC or PAL) to display live video.
 - Display captions Select this option if you want captions to be shown on the split screen.
- 4** Recording Specify the method of recording to use. It is possible to set the recording resolution (smaller resolution) different from the value in the Video settings group.
- 5** Detect events by Select the methods to use for detecting events. See "Methods of detecting events" for details.
- 6** Respond to events by Set up how Site Server will react to detected or manually triggered events.

- 7** Wide dynamic vision Select this option if you want to enhance the on- screen display of live camera video. There are three types of enhancements that can be adjusted: Visibility enhancement, Sharpness, and Noise reduction.
- 8** Notify if video loss Select this option if you want to be notified when there is a video loss problem with the cameras.
- 9** Apply All Click this button to use the same camera settings (except for the camera name) for all video cameras.

Note: Basic de-interlace processing is applied to 640x480, 720x480 and 720x576 resolutions, whereas advanced de-interlace processing is applied to the following high-definition resolutions: 640x480 HD, 720x480 HD and 720x576 HD. Advanced de-interlacing improves the video quality in scenes that contain fine details, however, it consumes more CPU power.

Configuring caption display settings

To display information (such as camera name, number, etc.) on the split screens, select the "Display captions" option and click Settings. Then in the Captions dialog box, choose the information to be displayed.

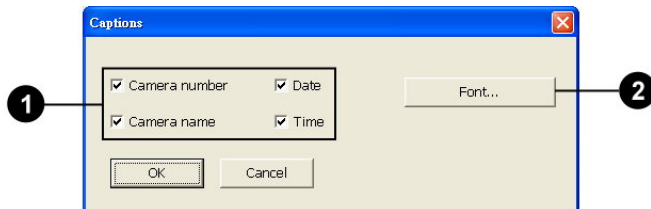

- 1** Caption checkboxes Select the checkboxes of the information that needs to be displayed on split screens.
- 2** Font Click this button to select a font face, font size, and font style to use for displaying captions.

Note: The selected font will be displayed in the actual font size only when the video dimension is set at 640x480. If, for instance, 32-point is the selected font size and the video dimension is set at 320x240, font will be scaled down to 16-point size.

When the "Display captions" option is enabled, a "REC" indicator will also be displayed on the split screens when the respective cameras are in the progress of recording video.

Digital recording

Select the "Enable recording" option to enable digital video recording. Choose the desired recording method from the drop-down list.

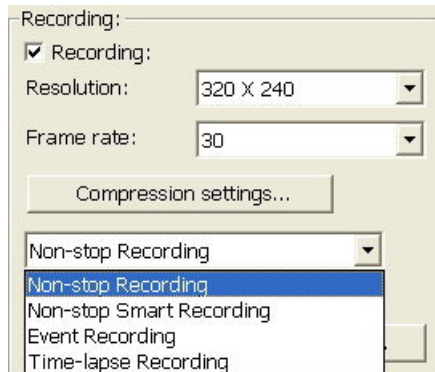

There are 4 recording methods:

- | | |
|--------------------------|--|
| Non-stop Recording | Allows round-the-clock digital recording. |
| Non-stop Smart Recording | Records live events in full recording speed. If no event has been detected, by default, the recording frame rate will be 1 frame per second. If there is an event detected, details of the event will be captured in full recording speed. |
| Event Recording | Records only detected events. (See "Specifying the methods for detecting events for details" on the different methods of detecting events.) |

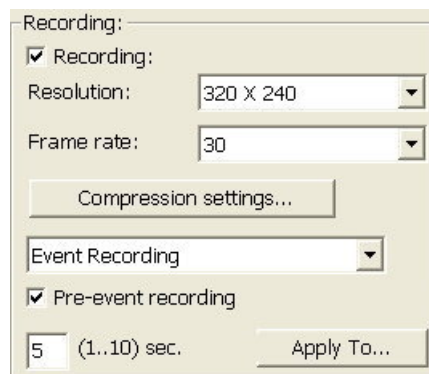

If you select the Pre-event recording option, video recording can be started before the detected event has actually occurred. You can capture from 1 up to 10 seconds of video prior to the event.

Note: Enabling pre-event recording may increase the video recording size.

Time-lapse Recording

Records video with specified frame rate below 1 fps. The range can be from 1 frame per second to 1 frame per day (86,400 seconds).

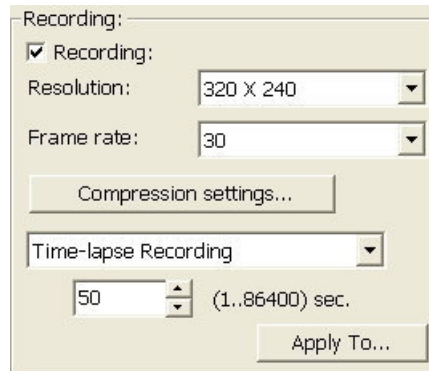

Specifying compression settings

In the Recording group box, click the Compression settings button to define compression settings.

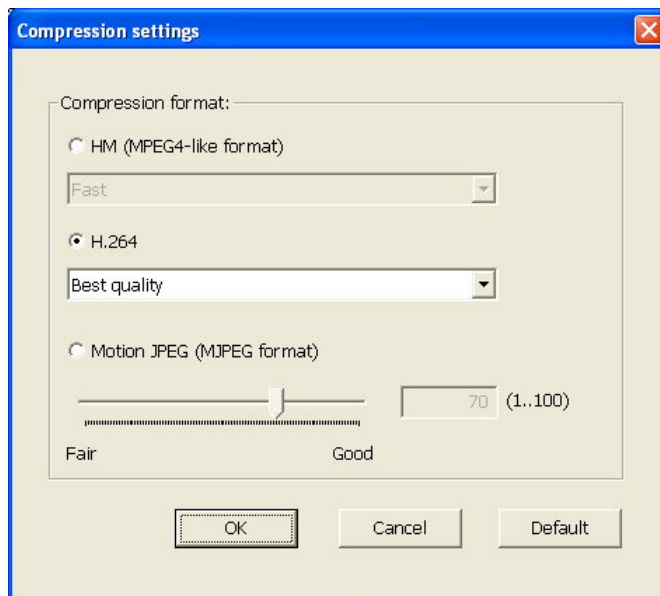

There are 3 compression methods:

HM

This is HuperLab's proprietary format for compressing video data. It has three levels of video quality you can choose from:

- Fast quality is the default. It offers the quickest recording speed and moderate file sizes. However, it provides the least video quality.
- Good quality gives you moderate video quality and the smallest file sizes. It offers moderate recording speed.
- Best quality offers the highest video quality. However, recording speed is slow and recordings have extremely large file sizes.

Fast
Good quality
Best quality

H.264

This is H.264 format for compressing video data. It has five levels of video quality you can choose from:

- Fast quality is the default. It offers the quickest recording speed and moderate file sizes. However, it provides the least video quality.
- Compact quality offers the same recording speed and file size as Fast quality. It consumes more CPU power to increase compression ratio.
- Good quality gives you moderate video quality and the smallest file sizes. It offers moderate recording speed.
- Better quality offers higher video quality. However, recording speed is slower and recordings have larger file sizes.
- Best quality offers the highest video quality. However, recording speed is slow and recordings have extremely large file sizes.

Fast
Compact
Good quality
Better quality
Best quality

Motion JPEG

This records video in Motion JPEG format. The video quality is adjustable, ranging from value 1 to 100. The higher the value, the better is the video quality.

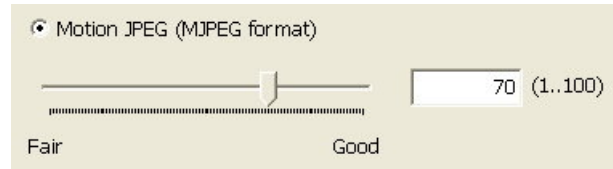

Methods of detecting events

Under the Detect events by group box, select the checkboxes of the methods to use for detecting events.

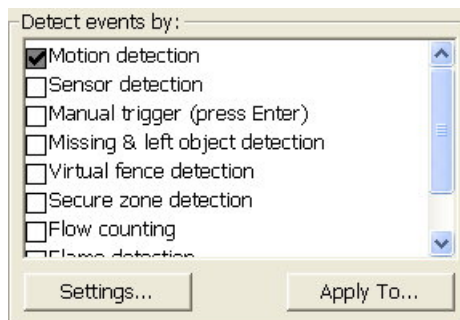

There are 9 methods for detecting events:

Motion detection

This allows video cameras to detect the presence of movement from a sequence of consecutive video frames. Click Settings to open a dialog box where you can adjust the sensitivity level, noise tolerance, and more. For more details, see "Motion detection" later in this chapter.

Sensor detection

This allows sensors in the site to monitor and detect suspicious activities. Click the Setting button to choose which sensors in the site will be used for detection.

Note: The sensor names here cannot be modified.

Manual trigger

This allows you to manually monitor activities in the site. You can press "Enter" to log and/or digitally record ongoing activities.

Note: Manual event duration is predefined in seconds.

Missing/left object detection	<p>This method detects for objects that have been taken out of the scene, or detects for suspicious objects that have been left on the scene.</p> <p>For more details, see "Missing/left object detection" later in this chapter.</p>
Virtual fence detection	<p>This method detects for possible intrusions along a borderline. You can specify one or more borderlines on a site where you want to detect for suspicious people who trespass, or detect moving objects that passed by in the wrong way (for example, vehicles that went in the opposite direction in a one-way street).</p> <p>For more details, see "Virtual fence detection" later in this chapter.</p>
Secure zone detection	<p>This method detects for intrusions in forbidden areas. You can specify one or more areas where people or objects are not allowed to enter.</p> <p>For more details, see "Secure zone detection" later in this chapter.</p>
Flow counting	<p>This method counts the number of moving objects that pass by a predefined borderline. For more details, see "Flow counting" later in this chapter.</p>
Scene Change Detection	<p>This method detect abnormal scene in camera video, please see Appendix 14.</p>
Flame detection(Optional)	<p>This method detects for flames. For more details, see "Flame detection" later in this chapter.</p>
Flame Detection Pro(Optional)	<p>This is the Professional version for Flame Detection, for more details, see Appendix 15.</p>
People counting(Optional)	<p>This method counts the number of moving people that pass by a predefined detection area. For more details, see "People counting" later in this chapter.</p>
Face Detection(Optional)	<p>This method detects face object in video and record in event database, see more detail, please see Appendix 13.</p>

Responding to events

Site Server can be configured to automatically respond to detected or manually triggered events. There are four options:

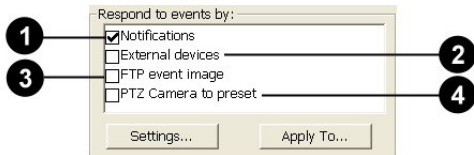

1 Notifications Select this option to enable Site Server to send out notifications when events have been auto-detected or manually triggered. Click the Settings button to select the types of notifications to send. (See the next section, “Types of notifications” for more details.)

2 External devices Select this option to enable Site Server to send out signals to external devices when events have been auto-detected or manually triggered. Click the Settings button to choose which external devices to send signals to.

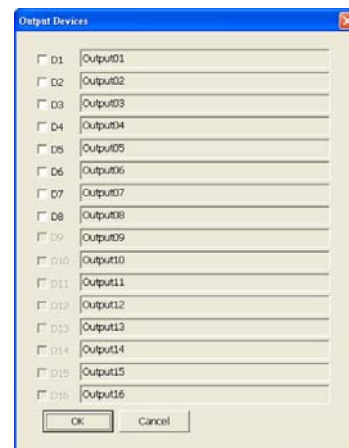

Note: The external device names here cannot be modified.

3 FTP event image Select this option to allow uploading of sequences of snapshots to an FTP server when an event has been detected.

4 PTZ camera to preset Select this option to allow any fixed surveillance camera to move one or more PTZ cameras to preset positions when there are motion detected, sensor detected, or manually triggered events.

Types of notifications

In the Notification dialog box, choose from the different types of notifications by selecting some or all of the checkboxes. For each selected type of notification, click its corresponding Options button to configure settings.

The screenshot shows a dialog box titled "Notifications" with a blue title bar and a close button (X) in the top right corner. The dialog contains several notification options:

- E-mail: A text field contains "huper@huperlab.com , sales@huperlab.com" and an "Options..." button.
- Fax: A text field contains "25994161" and an "Options..." button.
- Phone: An empty text field and an "Options..." button.
- Alarm: A dropdown menu shows "Dog Bark", followed by "Record", "Stop", and "Play" buttons. Below it is an unchecked Loop checkbox.
- Flash message at local site
- Flash message at remote site
- Change to single view and delay for: A spin box shows "5" and "sec.".

At the bottom of the dialog are "OK" and "Cancel" buttons.

■ Email

Send out an e-mail message. Configure the following settings to enable notification e-mails to be sent:

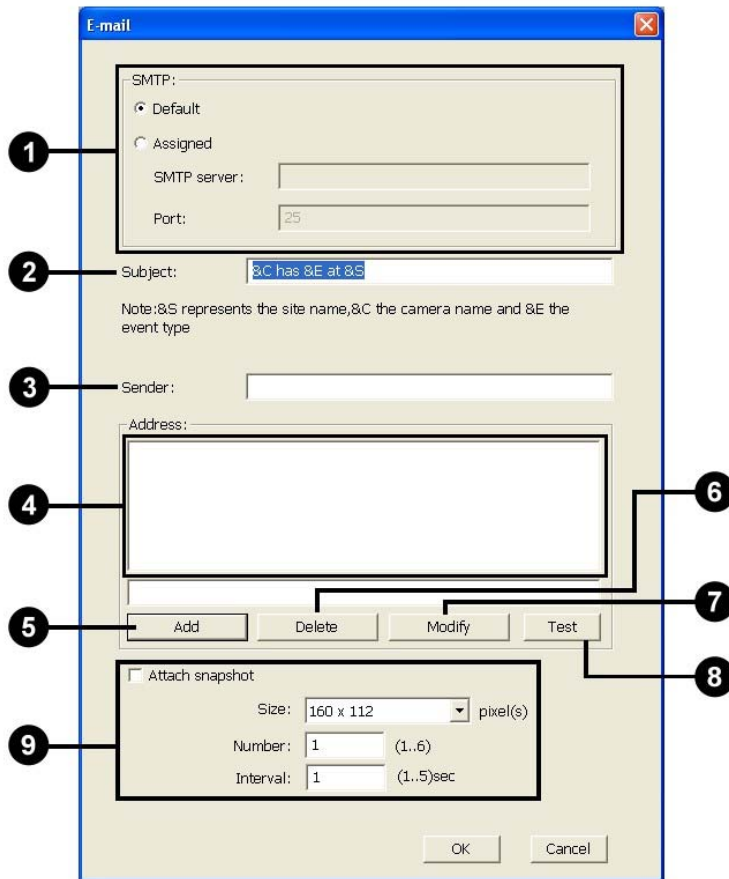

- 1** SMTP assignment Select Default to use huperVision built-in SMTP server emulation.
 Select Assigned to specify SMTP Server address and port number to use.
- 2** Subject By default, the e-mail subject contains variables that will automatically be replaced with the site name, camera name and event type. If you want to specify your own e-mail subject, type your text in the provided text box.
- 3** Sender Specify the sender's e-mail address.
- 4** Address list Shows the e-mail addresses that will receive the event notification. Click on an e-mail address to select it for deletion or modification.

- 5** Add Enter the e-mail address of a recipient in the blank field above this button, then click this button to add the e-mail address to the Address list.

- 6** Delete Click this button to remove the selected e-mail address from the address list.

- 7** Modify To modify an e-mail address, first select that e-mail address in the address list, then make the changes in the edit box at the bottom. Click the Modify button to update the e-mail address.

- 8** Test Click this button to test sending an email.

- 9** Attach snapshot Select this option to include one or more snapshots of a detected event as email attachment.

- Size Set the image dimensions. Choose a larger size if the attachment is to be sent to another computer. If the image is to be sent to a mobile device such as a mobile phone, choose the appropriate size for the target device.

- Number Set the number of snapshots to be attached. Maximum attachment can be up to 6 images.

- Interval Set the time interval between snapshots. The interval can be from 1 up to 5 seconds.

■ Fax

Send out a fax message. Configure the following settings to send fax:

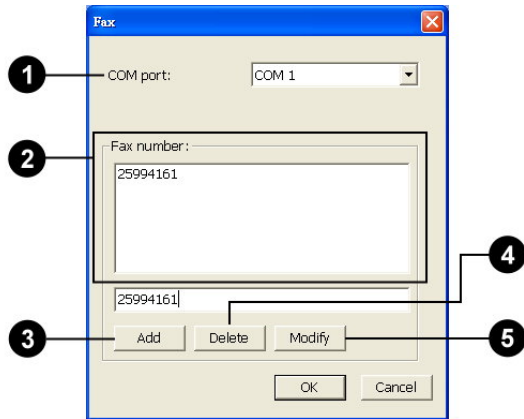

- 1** Com port Select one available Com port that connects to a modem device.
- 2** Fax list Lists the fax numbers that will receive the event notification. Click on a fax number to select it for deletion or modification.
- 3** Add Enter the fax number in the blank field then click this button to add the fax number to the Fax number list.
- 4** Delete Click this button to remove the selected fax number from the fax number list.
- 5** Modify To modify a fax number, first select that number in the fax number list, then make the changes in the edit box at the bottom. Click the Modify button to update the fax number.

■ Phone

Notifies by phone and sends out a voice message. Configure the following settings to be able to dial out and send voice messages.

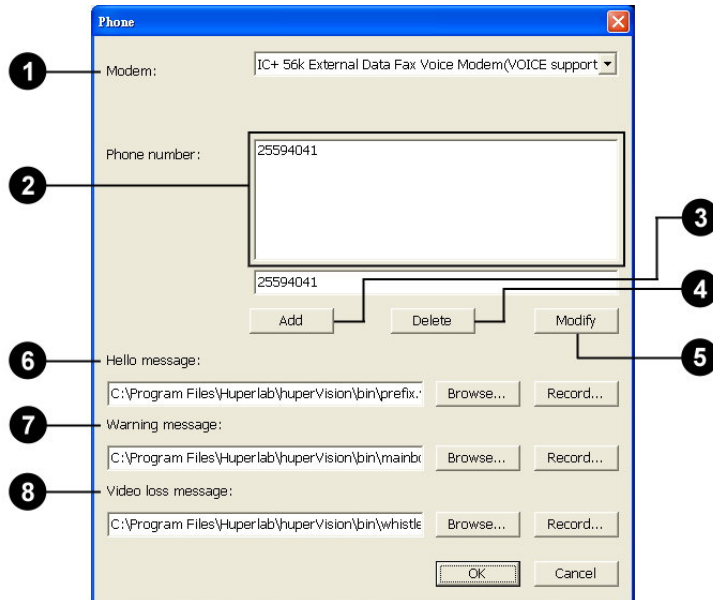

- 1** Modem Select an available modem driver that has the voice support.
- 2** Phone list Lists the phone numbers that will receive the event notification. Click on a phone number to select it for deletion or modification.
- 3** Add Enter the phone number in the blank field then click this button to add the number to the Phone number list.
- 4** Delete Click this button to remove the selected telephone number from the telephone number list.
- 5** Modify To modify a telephone number, first select that number in the telephone number list, then make the changes in the edit box at the bottom. Click the Modify button to update the telephone number.
- 6** Hello message Select a wave file or click the Record button to record a hello message.

Note: The voice message should be recorded with at least PCM 8kHz, 16-bit mono audio format.

- 7** Warning message Select a wave file or click the Record button to record a warning message. The hello message will be dispatched first, followed by the warning message.
- If the recipient of the message wants to skip the hello message and directly listen to the warning message, he/she can press any key on the phone.
- 8** Video loss message Select a wave file or click the Record button to record a voice message that will be sent in the event when there is a video loss problem. The hello message will be dispatched first, followed by the video loss message.
- If the recipient of the message wants to skip the hello message and directly listen to the video loss message, he/she can press any key on the phone.

- Alarm

Play an alarm sound. From the drop-down list, select from the available sounds, or select "Custom" and then click Record to record your own alarm sound. To listen to a preview of your recorded sound, click Play. You can also select the "Loop" option to sound the alarm until the event terminates.

- Flash message at local site

An "Event" indicator will be displayed if and only if the "Flash message at local site" checkbox is selected in the Notification dialog box. A blinking "Event" indicator will be displayed on the bottom left corner of a split screen on Site Server when an event is detected.

- Flash message at remote site

Display an "Event" indicator on the Remote Viewer interface of users who are remotely viewing your video cameras from a Web browser. A blinking "Event" indicator will be displayed on the top, central portion of a split screen on the Remote Viewer when an event is detected.

- Change to single view and delay for ___ seconds

Switches the Site Server screen to single view to display live the camera from which an event has been detected. Specify the duration (in number of seconds) for retaining the display in single view (after the event occurs) before changing Site Server back to split-screen view.

Uploading event snapshots to an FTP server

Select the FTP event image option under the Respond to events by group box in the Camera tab if you want the Site Server to take snapshots when there is a motion detected, missing object or suspicious object left on scene that is detected, sensor detected, or manually triggered event and then upload the images to an FTP server. After selecting this option, click the Settings button to open the FTP event image dialog box where you can specify the FTP server details and customize how snapshots should be taken.

- | | | |
|----------|-----------------------|--|
| 1 | FTP server IP address | Specify the IP address (or URL) of the FTP server. |
| 2 | FTP server TCP port | Specify the TCP port at which the FTP server is located. (By default, this is port 21.) |
| 3 | Location | Specify the directory path on the FTP server where event snapshots will be uploaded to. |
| 4 | User | Specify a valid user name that has write access rights and that will be used to logon to the FTP server. |
| 5 | Password | Enter a valid password for the specified user name. |
| 6 | Event image Size | Specify how event snapshots are to be taken.
Set the image size. Available sizes include: 96 x 80, 112 x 112, 128 x 96, 144 x 144, 160 x 112, 176 x 144, 208 x 192, 320 x 240, 352 x 240, 640 x 480, and 720 x 480. |

Number	Set the number of snapshots to be taken for each detected or manually triggered event. Maximum number of snapshots can be up to 6 images.
Interval	Set the time interval between snapshots. The interval can be from 1 up to 5 seconds.

Notes:

- Event snapshots are saved in the temp folder that is specified in the General tab of the Preferences dialog box before they are uploaded to the FTP server (or e-mailed).
- Event snapshots will be deleted from the temp folder after they have been uploaded to the FTP server (or e-mailed).
- When FTP upload (or e-mail) fails, Site Server will try transmission again after five minutes. At most, 48 tries will be attempted (i.e., about 4 hours in total). If, after exceeding this maximum number of attempts, FTP upload (or e-mail) is still unsuccessful, the images will be removed from the temp folder and the transmission error will be recorded into the operation log. The About button will also appear in red as an indicator that an error has occurred.
- The maximum number of event snapshots that can be stored in the temp folder is determined by the DVR system at runtime. If the maximum allowable limit has been exceeded, older images will be removed automatically to free up disk space for storing new event snapshots.

Moving PTZ cameras during an event

Select the PTZ camera to preset option under the Respond to events by group box in the Camera tab if you want any fixed surveillance camera to move PTZ cameras to preset positions when there are auto detected events or manually triggered events. Click the Settings button to open the PTZ camera to preset dialog box where you can choose one or more PTZ cameras to move as well as specify the preset positions where to move them during an event and after the event has ended.

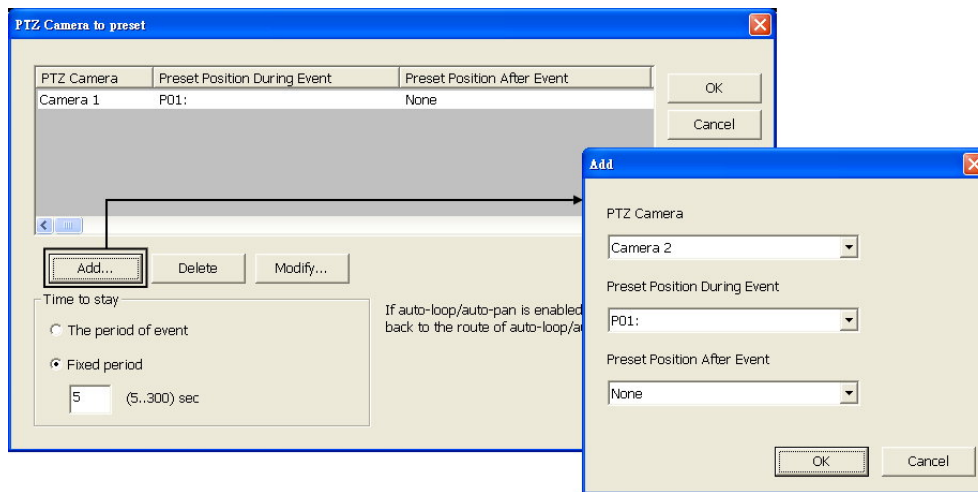

Follow these steps to choose one or more PTZ cameras and select preset positions:

1. Click Add.
2. In the Add dialog box, first select the desired PTZ camera number from the PTZ camera drop-down list. Then from the PTZ camera preset during event drop-down list, choose a preset position where you want to move the PTZ camera during an event.
3. If you want to move the PTZ camera to another position after the event has ended, select the desired preset position from the PTZ camera preset after event drop-down list. If you select None, the PTZ camera will stay at its current position when auto-loop or auto-pan mode is disabled. When auto-loop or auto-pan mode is enabled, selecting None will resume the PTZ camera to either of these two modes depending on which one of them is enabled.
4. Click OK to return to the PTZ camera to preset dialog box.
5. To add more PTZ cameras, repeat steps 1 to 4. To change position settings of a PTZ camera, select its camera number from the list then click Edit.
6. In the Time to stay group box, you have two choices for setting the time length for letting the PTZ camera stay at a preset position:

- **The period of event** Select this option to keep the PTZ camera at the preset position during the whole event. Sometimes, an event period might be as short as 0 or 1 second (such as a motion event or video loss event). Moving a PTZ camera to a preset position and staying there for only 0 or 1 second is not relevant. Also, some PTZ cameras may not be able to process multiple commands in such a short period of time. In these cases, a minimum dwelling period of 2 seconds will be set.
- **Fixed period** Select this option if you want to specify fixed time duration. Enter the desired duration in the provided text

Note: A fixed surveillance camera can drive one or more PTZ cameras at the same time. While a PTZ camera stays at a designated preset position, it will reset the duration of this position and accept another request only at the following conditions:

- The request is from the same fixed camera.
- The request is from another fixed camera that has higher priority.

Video loss notification

Select the Notify if video loss option in the Camera tab if you want the Site Server to issue notifications when there is camera video loss.

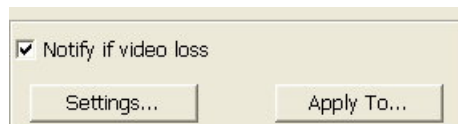

After selecting this option, click the Apply To button and select which cameras that you want to monitor for video loss problems.

Click the Settings button to open the Video Loss Notification dialog box where you can choose the desired types of notifications: E-mail, Phone, and Alarm.

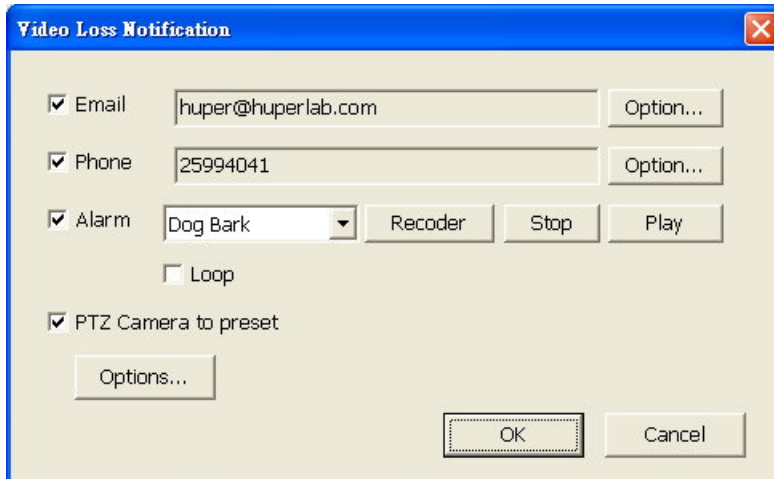

For each type of notification that you selected, click the corresponding Options button to customize notification settings. For details on how to customize, see "Types of notifications" earlier in this chapter.

In the Video Loss Notification dialog box, you can also select the PTZ camera to preset checkbox if you want the cameras that lost their video signal to move PTZ cameras to preset positions so that you can still see live video. Underneath this checkbox, click the Options button to open the PTZ camera to preset dialog box where you can choose the PTZ cameras that you want to move and specify preset positions for these PTZ cameras. For details on how to do this, refer to the procedure in the section "Moving PTZ cameras during an event".

IP camera settings (Camera tab)

Click the Camera tab in the Preferences dialog box to configure settings for IP cameras if you have IP license. Each IP camera is identified by a camera number (IPx). Click each camera button to set up options for an IP camera.

Note: The starting channel number of IP camera depends on the total channel number of video cameras.

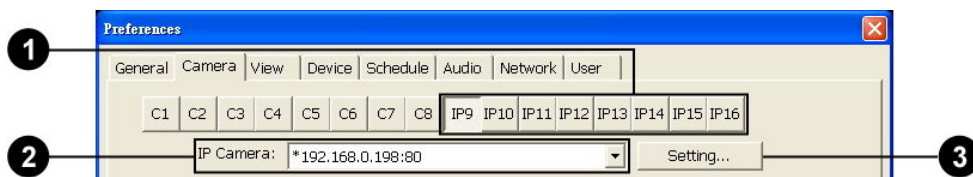

- 1** Camera buttons Each button corresponds to an IP camera. Click a button to configure settings for an IP camera.
- 2** IP camera list Lists the IP cameras that can be assigned. Select a camera from list to .assign for this channel.
- 3** Setting Click this button to configure the contents of IP camera list including adding, deleting or modifying IP cameras.

Note: The * mark in front of IP address in the IP camera list means this IP camera has been assigned.

Configuring IP camera settings

Click Setting button in the Preferences Camera page to pop-up IP camera dialog box.

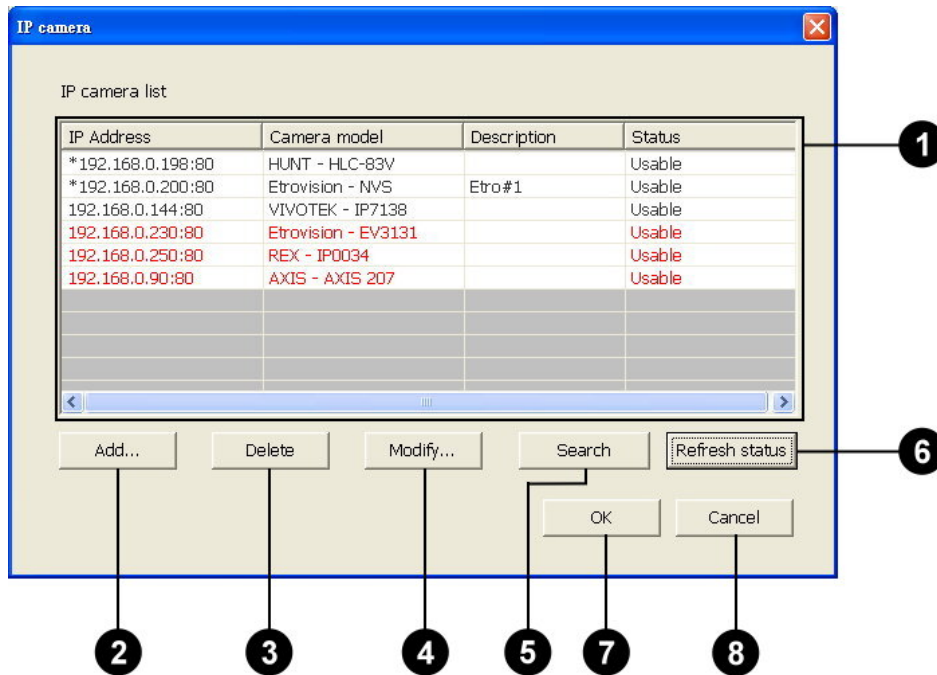

- 1** IP camera list List of available IP cameras displayed in the Preferences Camera page.
- IP address Used IP address for the camera.
- Camera model IP camera model
- Description Description text of IP camera for display only.
- Status Display camera connection status after refreshing status.
- 2** Add Pop-up dialog to add IP camera to the list manually.
- 3** Delete Remove the selected IP camera from list.
- 4** Modify Pop-up dialog to modify camera settings.
- 5** Search Search currently available IP cameras in the network.
- 6** Refresh status Checking connection status of IP cameras in the list.
- 7** OK Update IP camera list and back to the Preferences Camera page.
- 8** Cancel Restore IP camera list and back to the Preferences Camera page.

Add to IP camera list

In the IP camera dialog box, click the Add button to add IP camera manually into the list.

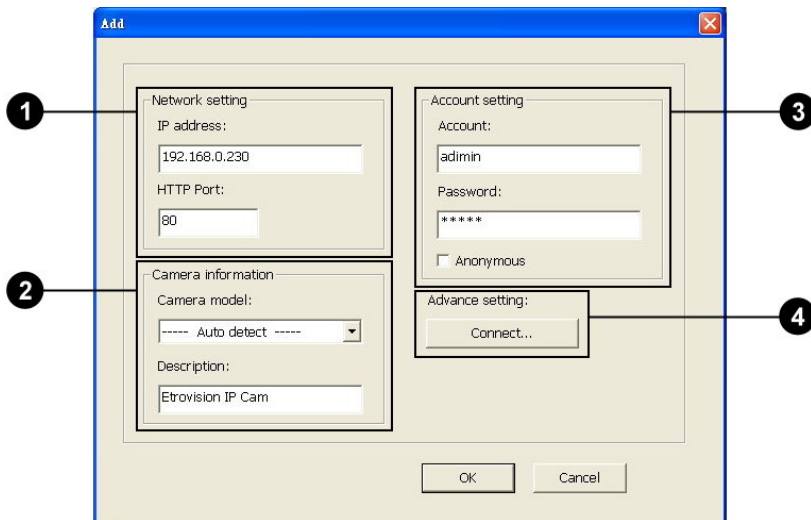

- | | |
|---|--|
| <p>1 Network setting</p> <p>IP address</p> <p>HTTP port</p> | <p>Network related settings for connecting IP camera</p> <p>IP address of added camera</p> <p>HTTP port for connecting IP camera. Default value is 80.</p> |
| <p>2 Camera information</p> <p>Camera model</p> <p>Description</p> | <p>Camera</p> <p>Select camera model from the porting list. Default value is Auto detect.</p> <p>Description text of IP camera for display information only</p> |
| <p>3 Account setting</p> <p>Account</p> <p>Password</p> <p>Anonymous</p> | <p>Settings to login IP camera</p> <p>User account to login IP camera</p> <p>Account password to login IP camera</p> <p>Check this option to login IP camera without account & password.</p> |
| <p>4 Advance setting</p> <p>Connect</p> | <p>Advance features to adjust camera settings</p> <p>Pop-up web page to setup camera in details.</p> |

Note: The connection may fail if choosing wrong camera model.

Note: Not every IP camera model supports this feature.

Modify IP camera configuration

In the IP camera dialog box, select an item from list and click the Modify button to modify the camera configuration.

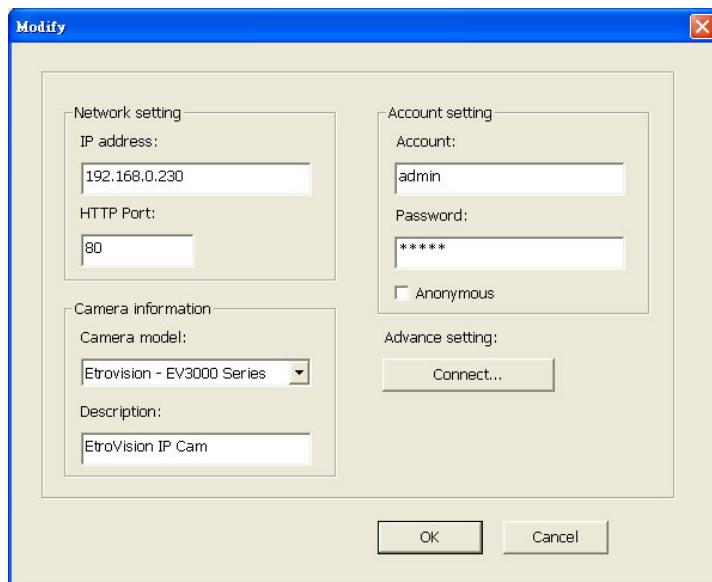

The 'Modify' dialog box is a standard Windows-style window with a blue title bar and a close button. It contains several sections for configuration:

- Network setting:** Includes 'IP address' (text box with '192.168.0.230') and 'HTTP Port' (text box with '80').
- Account setting:** Includes 'Account' (text box with 'admin'), 'Password' (text box with '****'), and an 'Anonymous' checkbox (unchecked).
- Camera information:** Includes 'Camera model' (dropdown menu showing 'Etrovision - EV3000 Series') and 'Description' (text box with 'EtroVision IP Cam').
- Advance setting:** Includes a 'Connect...' button.

At the bottom of the dialog are 'OK' and 'Cancel' buttons.

All the operations are the same as Adding IP camera. Please refer to " Add to IP camera list " for details.

Search IP camera

In the IP camera dialog box, click the Search button to search currently available IP cameras..

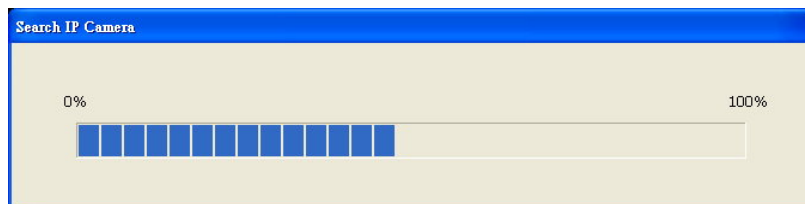

The 'Search IP Camera' dialog box features a blue title bar and a progress bar. The progress bar is labeled '0%' on the left and '100%' on the right. The bar itself is filled with blue segments, indicating that the search process is in progress.

After searching process, additional available IP cameras will be added in the IP camera list in **RED** text. Click OK will add these available cameras to the list and can be selected in Preferences Camera page. Click Cancel will restore IP camera list without change.

IP Address	Camera model	Description	Status
*192.168.0.198:80	HUNT - HLC-83V		
*192.168.0.200:80	Etrovision - NVS	Etro#1	
192.168.0.144:80	VIVOTEK - IP7138		
192.168.0.250:80	REX - IP0034		
192.168.0.230:80	Etrovision - EV3131		
192.168.0.90:80	AXIS - AXIS 207		

Update status of IP camera list

In the IP camera dialog box, click the Refresh status button to update IP camera status in the list.

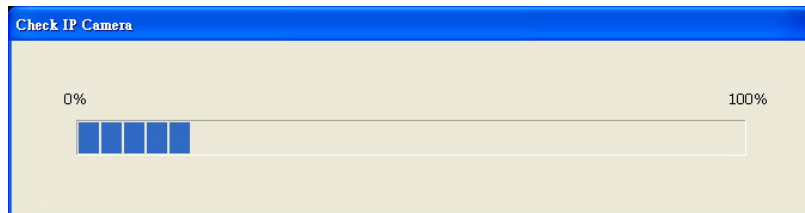

After updating status of IP camera, it will display current IP camera status as below::

IP Address	Camera model	Description	Status
192.168.0.198:80	HUNT - HLC-83V		Usable
192.168.0.144:80	VIVOTEK - IP7138		Usable
192.168.0.200:80	Etrovision - NVS		Usable
192.168.0.250:80	REX - IP0034		Usable
192.168.0.230:80	Etrovision - EV3131		Usable
192.168.0.90:80	AXIS - AXIS 207		Usable
192.068.0.66:80	Etrovision - NVS		Usable

IP Camera with black text

Indicates that usable online IP cameras

IP Camera with gray text

Indicates that unavailable offline IP cameras

IP Camera with red text

Indicates that usable online IP camera (after searching IP cameras)

Split screen settings (View tab)

Click the View tab in the Preferences dialog box to assign several video cameras per split screen. The assigned video cameras will take turns, and each camera will be displayed for a specified amount of time.

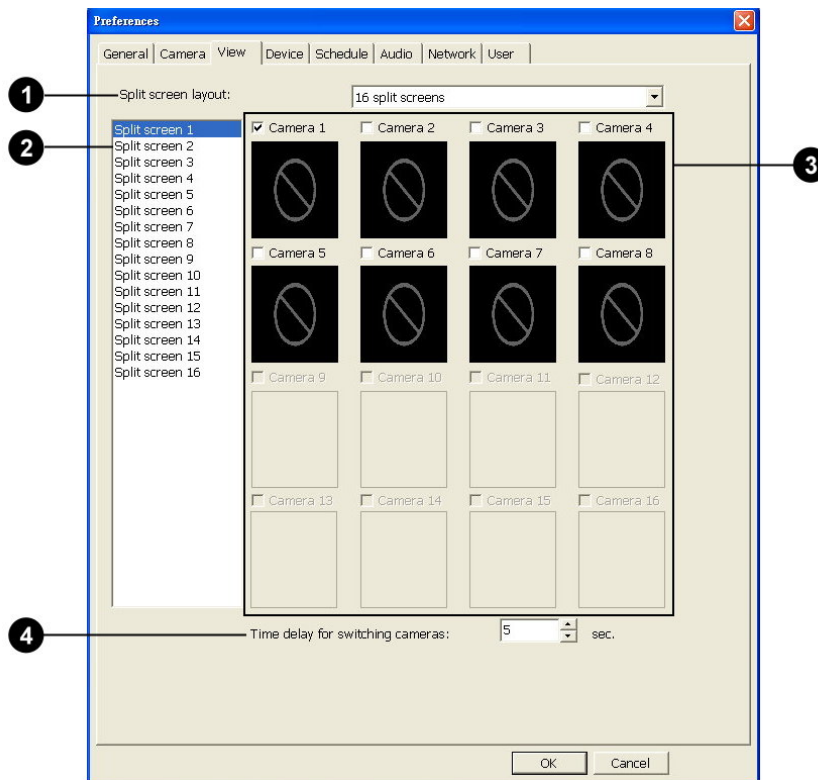

- 1** Split screen

Choose a split screen layout on which to assign video cameras for display. Select any of Site Server's preset layouts: Single View, 4 Split Screens, 9 Split Screens, or 16 Split Screens.
- 2** Split screens list

This lists the split screens that are displayed on a given screen layout.
- 3** Camera assignments

When you highlight a split screen number on the list at the left, the right side of the dialog box shows the video cameras that are currently assigned to that split screen. Assigned video cameras are indicated by the selected checkboxes.

Select/clear checkboxes to change the assignment video cameras.

- 4** Time delay for switching cameras Per split screen, specify the time duration for displaying each of the assigned video cameras. The duration can be set from 1 second up to 360 seconds.

Input/Output device settings (Device tab)

Click the Device tab in the Preferences dialog box to select an I/O card and set up the connections to security devices such as sensors and alarms. Under the Device tab, click the "Input" tab to configure sensor devices, and click the "Output" tab to enable devices to receive signals from Site Server.

Configuring input devices (Input tab)

In the "Input" tab, at most 16 sensor devices can be enabled and customized. The following describes the settings that can be customized.

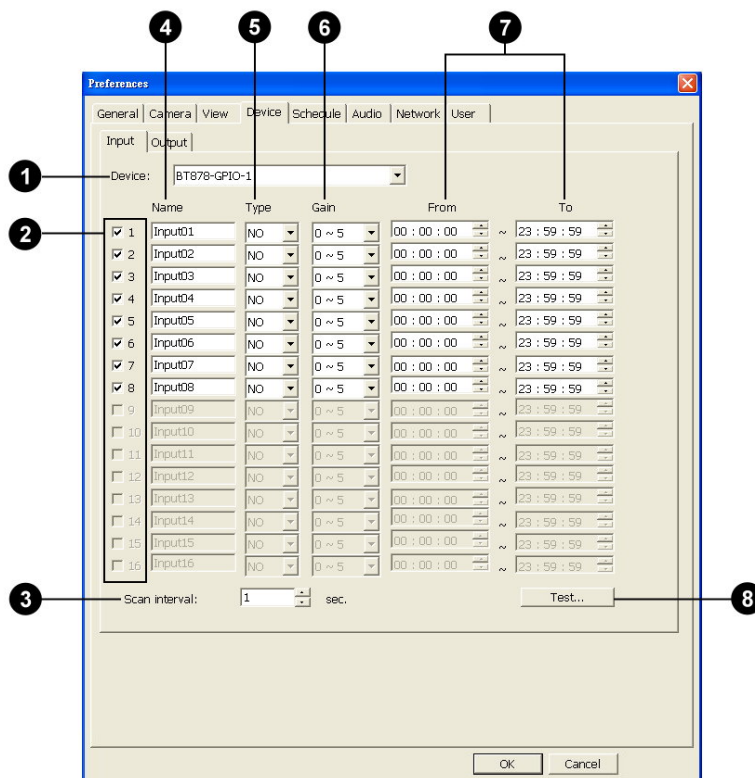

- 1** Device Select an I/O card from the drop-down list. Different I/O cards have different number of analog input ports.
- 2** Enable/Disable checkboxes Select the checkboxes of sensors whose analog input will be monitored. Or, clear the checkboxes to disable connections to the sensors.

- | | | |
|----------|---------------|--|
| 3 | Scan interval | Specify the interval (in seconds) for scanning input ports periodically. |
| 4 | Name | Specify the sensor name (for instance, the location where the sensor is installed). |
| 5 | Type | Select an input type: NC (Normal Close) or NO (Normal Open). |
| 6 | Gain | Specify the sensor's input voltage range. |
| 7 | From/To | Specify the time period for monitoring the sensor's analog input. |
| 8 | Test | <p>Click this button to open the "Sensor test" dialog box to view the actual analog input voltage value.</p> <p>The Sensor test dialog box allows you to check the connection status of input devices. The sensor input type and the current voltage value are displayed. You can try each input devices and inspect the voltage to check if the connections between input devices and Site Server are well connected.</p> |

Configuring output devices (Output tab)

In the "Output" tab, at most 16 output devices can be enabled and customized. The following describes the settings that can be customized.

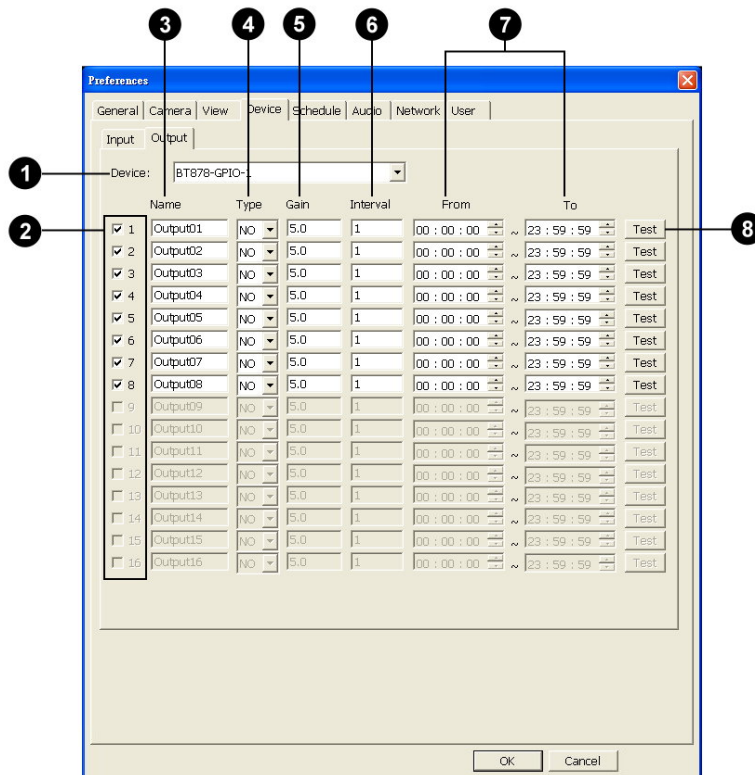

- 1** Device Select an I/O card or I/O box from the drop-down list. Different I/O cards or I/O boxes have different number of analog output ports.
- 2** Enable/Disable checkboxes Select the checkboxes of devices to connect to, or clear the checkboxes to disable connections to the devices.
- 3** Name Specify the output device name (for instance, the location where the output device is installed).
- 4** Type Select an output type: NC (Normal Close) or NO (Normal Open).
- 5** Gain Specify the output voltage.
- 6** Interval Specify the interval for sending the specified output voltage to the device.
- 7** From/To Specify the valid time period for activating the output device.
- 8** Test Click this button to output the specified voltage to NO-type devices and output 0 voltage to NC-type devices during the specified interval.

Timed surveillance settings (Schedule tab)

Click the Schedule tab in the Preferences dialog box to set up a surveillance schedule for each video camera. Timed surveillance can be scheduled in a daily, weekly, or monthly basis.

By Day

To set up a daily surveillance schedule for each video camera:

1. Choose a video camera by clicking the number button that corresponds to that camera.
2. Select the "Enable scheduling" option.
3. From the "Type" drop-down list, select "By day".
4. To add a new schedule, click "Add".
5. In the dialog box that opens, set a time schedule for monitoring the camera and select the checkboxes of tasks to be performed within the scheduled time.
(See next page for more details.)
6. Repeat steps 1 to 5 to add more schedules.
7. All created time schedules will be added to the schedule list in the Schedule tab.
To select a schedule and view details, click its "Start Time" entry.
To delete a schedule, select it and click the Delete button.
To modify a schedule, select it and then click the Modify button.
8. Repeat steps 1 to 7 to create daily schedules for other video

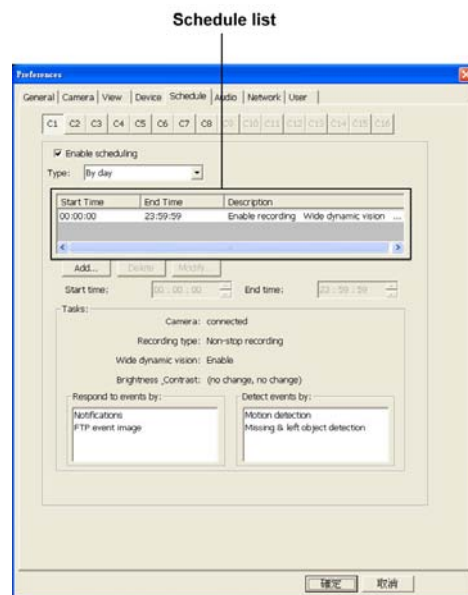

Note: Time segments that are not listed in the Schedule list will use the options set in the Preferences - Camera tab.

Daily surveillance settings

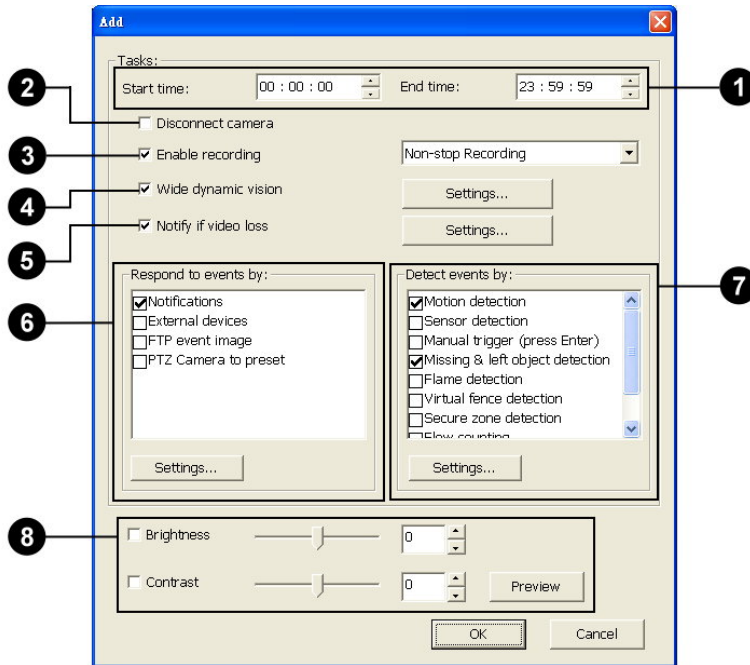

- | | | |
|----------|----------------------|---|
| 1 | Start / End time | Specify what time to monitor and detect events. |
| 2 | Disconnect camera | Select this option to disconnect the camera during the time period specified by the "Start / End" time settings. |
| 3 | Enable recording | Select this option to enable digital recording during the scheduled time period. Choose a recording method from the drop-down list. |
| 4 | Wide dynamic vision | Select this option to enhance camera video quality. Click the Settings button to make adjustments. |
| 5 | Notify if video loss | Select this option to be informed when certain cameras lose their video signal. Click Settings to set up the type of notification (by e-mail, phone, etc.). |
| 6 | Respond to events by | Choose the methods for responding to detected or manually triggered events. |

- 7** Detect events by Select one or more detection methods, then click the Settings button to customize settings for each selected method.
- 8** Brightness / Contrast Adjust the camera brightness and contrast if necessary. After adjustment, you can click Preview to see how the camera video appears. If the camera is currently in the process of recording events, the preview result will appear on the recording.

Note: If you tweak brightness and contrast settings on the Camera Adjustment Panel of the Site Server interface while a scheduled task is enabled, your modified settings will be updated to the brightness and contrast settings of the scheduled task. However, if the scheduled task is not configured with any brightness and contrast settings, then your adjustments on the Camera Adjustment Panel will just affect the live camera display.

By Week

To make a weekly surveillance schedule for each video camera:

1. Choose a video camera by clicking the number button that corresponds to that camera.
2. Select the "Enable scheduling" option.
3. From the "Type" drop-down list, select "By week".

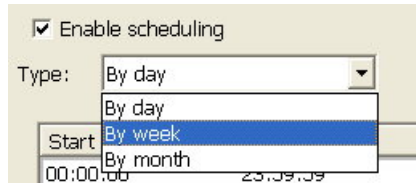

4. By default, the weekday list shows Saturday and Sunday as the days off and the other days as workdays. You may change the type of day for the days listed. For instance, to change Sunday to be a special day, click "Sunday" and then select the "Special day" option.

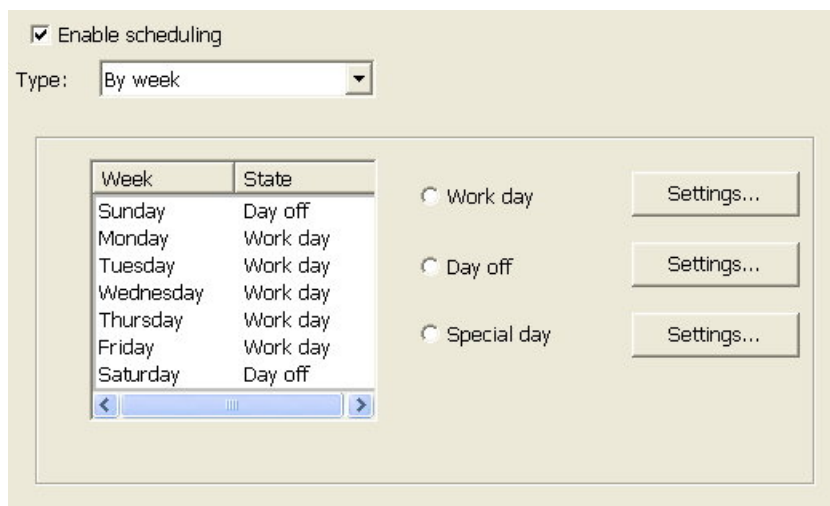

5. You can create different surveillance schedules for work days, off days, and special days. Click the "Settings" button beside each of the three options to set the surveillance schedule for each.

The procedure for setting the weekly surveillance schedule is just the same as that for setting the daily surveillance.

6. Repeat steps 1 to 5 to create weekly schedules for other video cameras.

By Month

To make a monthly surveillance schedule for each video camera:

1. Choose a video camera by clicking the number button that corresponds to that camera.
2. Select the "Enable scheduling" option.
3. From the "Type" drop-down list, select "By Month".
4. The calendar shows the current month, with the current day highlighted. Also, by default, Saturday and Sunday are defined as the days off and the other days as workdays.

Enable scheduling
 Type: By month

May, 2008						
Sun	Mon	Tue	Wed	Thu	Fri	Sat
27	28	29	30	1	2	3
4	5	6	7	8	9	10
11	12	13	14	15	16	17
18	19	20	21	22	23	24
25	26	27	28	29	30	31
1	2	3	4	5	6	7

Work day Settings...
 Day off Settings...
 Special day Settings...

You may change the type of day for any day of the month. Just click on a day in the month calendar, then click the type of day ("Work day", "Day off", or "Special day") at the right.

5. To change the type of day in other months, move to the other months by clicking the arrow buttons on top of the calendar. Do the process mentioned in step 4 to change the type of day for any day of the month.
6. The procedure for setting the surveillance schedule for days of a given month is just the same as that for setting the daily surveillance.

Audio capturing device settings (Audio tab)

Click the Audio tab in the Preferences dialog box to configure the settings for up to 16 audio devices. Please be sure to associate video cameras and audio input devices according to their correct practical deployment.

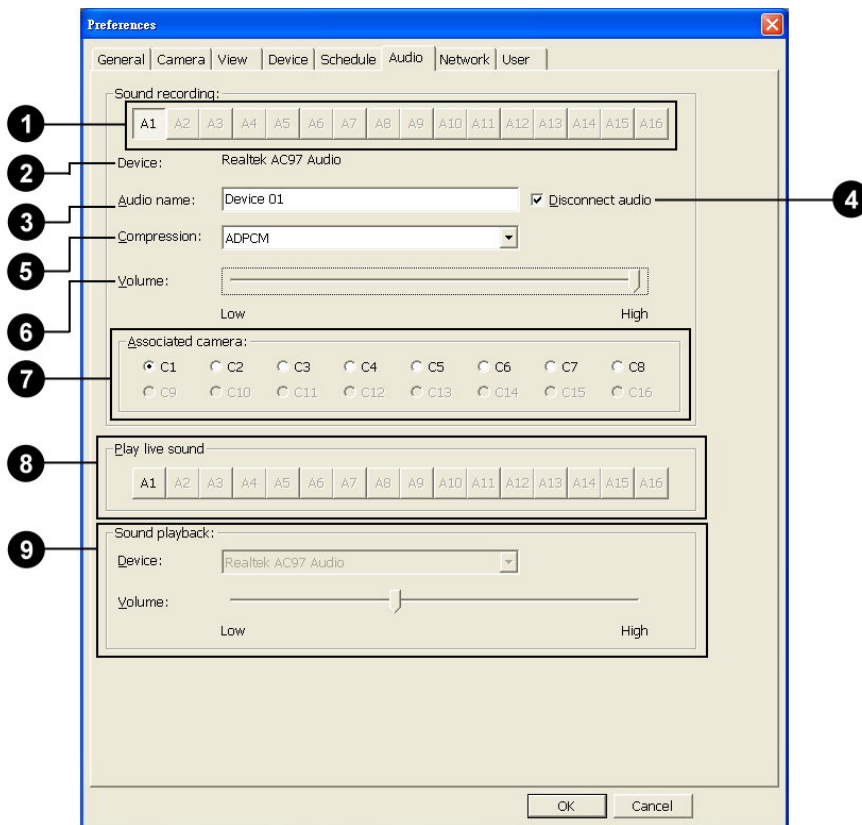

- 1** Audio buttons Each button corresponds to an audio input device. Click a button to configure settings for an audio recording device.
- 2** Device Displays the audio input device name.
- 3** Audio name Type in a name for identifying the audio recording from the audio input device (for instance, the location where the audio recording device is installed).
- 4** Disconnect audio Select to stop recording audio from this particular audio input device. Clear to reconnect to the audio input device.
- 5** Compression This determines the recorded audio quality and the resulting file size. Currently, only the Microsoft® ADPCM compression scheme is available.

- 6** Volume Determines the record volume level of the audio input device. Use the slider to adjust the volume level.
- 7** Associated camera Each radio button corresponds to a video camera. Select a video camera you want to associate with the audio input device (A1 to A16). You can only associate one camera per audio recording device.
- 8** Play live sound Each button corresponds to an audio input device. Click a button to hear the audio when viewing the camera associated with the audio recording device.
- 9** Sound playback Displays the audio device used by your computer to play back audio from the audio recording device. You can also adjust the playback device's volume here. If you have more than one audio device installed, select the device you want to use from the drop-down menu.

Web Server and Video Server settings (Network tab)

In the Network tab of the Preferences dialog box, you can set up the Site Server computer as a Web Server and a Video Server. When configured as a Web server, the system will allow remote users to view video cameras remotely via a Web browser on a computer or mobile phone. Whereas, when configured as a Video server, the system will allow video streaming across the Internet when remote users view the on-site cameras.

Web Server

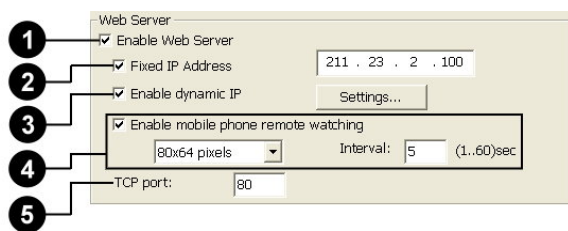

- 1** Enable Web Server Select this option to configure Site Server as a Web server. When acting as a Web server, Site Server will allow remote access to its live video cameras. Remote users can launch Microsoft Internet Explorer and type in the IP address of the Site Server computer to download a four split-screen Web page and remotely monitor the cameras via the Internet.
- 2** Fixed IP address If your computer is installed with two network cards and owns two IP addresses, select this option and enter the IP address that you would like to assign to the Web
- 3** Enable dynamic IP Select this option if the Site Server uses a dynamic IP address (i.e., an IP address that varies each time the computer connects to the Internet). Set the dynamic IP options by clicking Settings.
The Site Server computer will report the current IP address to the Dynamic IP Server. Remote users can use a Web browser to log into the Dynamic IP Server and then connect to the Site Server computer and remotely monitor the on-site video cameras.

- 4** Enable mobile phone remote watching

Select this option to allow remote users to monitor the on-site cameras via a Web browser on their mobile phone. Set the appropriate Video dimension for the target mobile phones and specify the Interval between surveillances. Note: Currently, only the following mobile phones are supported: Docomo iMode phone, J-phone, and AU-phone.
- 5** TCP port

Specify a TCP port number to be used by the Web server. The chosen TCP port must not be unique and unused by other applications.

Video Server

The screenshot shows the 'Video Server' configuration window. It includes the following elements:

- 6** Video dimension: A dropdown menu set to '320x240'.
- 7** Video compression: A dropdown menu set to 'Fast quality'.
- 8** Performance: A slider control ranging from 'Low' to 'High', currently set at '1'.
- 9** Video port: A table with the following data:

No	Frame rate	Fault tolerance	TCP Port
1	12	Medium	18082
2	10	High	18083

A 'Modify' button is located at the bottom right of the window.

- 6** Video dimension

Specify a fixed video dimension for streaming video to remote clients. Set this to the "Original video dimension" or "320 x 240".

When you set the dimension to "320 x 240" and the source video is in "640 x 480" for instance, the video will be re-sampled to 320 x 240 first before it is streamed over the Internet.
- 7** Video compression

Compressing video makes the video file size smaller and allows faster video streaming. Choose one of the following compression methods: "Fast quality", "Best quality", or "Good quality".

Note: Each compression method has its own GOP and QP settings that are stored in the LiveTag.ini file under the program folder. After you have chosen a compression method, its corresponding settings will be updated to the Server.ini file.

- 8** Performance The performance value represents the number of threads in a multi-threading capable system that will be allocated for handling video streaming operations.
- For instance, if there are 16 video cameras connected to a Site Server computer, allocating two threads to share the workload of streaming the video from the cameras will provide a higher performance than assigning only a single thread.
- 9** Video port By default, two TCP ports are allocated to listen to video streaming requests.

To define the settings for each TCP port, click Modify and set the following:

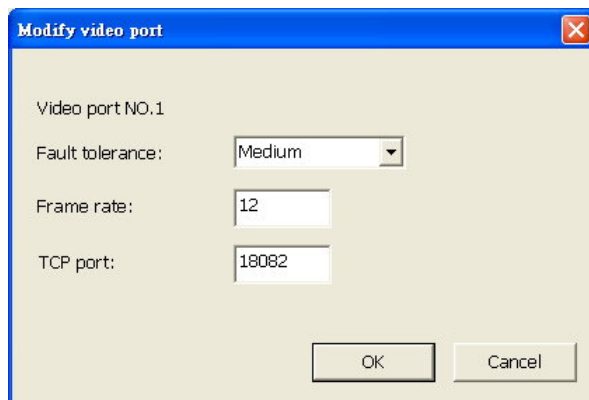

- Fault tolerance** Set the number of retries when problems occur during video streaming. "Low" represents 50 retries, "Medium" for 100 retries, and "High" for 200 retries.
- Frame rate** Specify the maximum frame rate that the TCP port will use for video streaming. 1 up to 30 fps can be set.
- TCP port** Assign the desired TCP port number. Default TCP port numbers are 18082 for video port 1 and 18083 for video port 2.

Configuring dynamic IP settings

If the Site Server computer connects to the Internet using a dynamic IP address and you want remote users to be able to locate it over the Internet, you need to configure the dynamic IP settings. Click Settings to set the dynamic IP options.

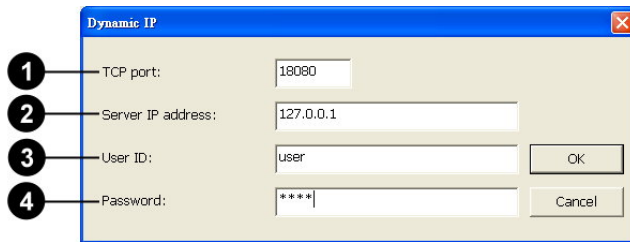

- | | | |
|---|-------------------|---|
| ❶ | TCP Port | Specify the port of the dynamic Web server. |
| ❷ | Server IP address | Specify the IP address of the dynamic Web server. |
| ❸ | User ID | Specify a user ID for the person you will give authorization to have access to your computer. |
| ❹ | Password | Specify a password for the user ID. |

It is strongly recommended that a user ID and password be defined when the Enable Dynamic

IP option is selected. By specifying a user ID and password, the Site Server computer will be more secure and only personnel you have given authorization to will be able to access the computer.

Accessing the dynamic IP server site

After configuring the dynamic IP settings, the Site Server automatically registers the IP address, user ID and password on the dynamic IP server. Remote users who want to monitor video cameras remotely on a dynamic IP server must perform the following steps.

For remote users to view video cameras on the dynamic IP server:

1. Launch a Web browser such as Internet Explorer, then enter the dynamic IP server's URL in the Address box.
2. Enter the user ID and password. If no user ID and password have been assigned, click the "Submit" button.

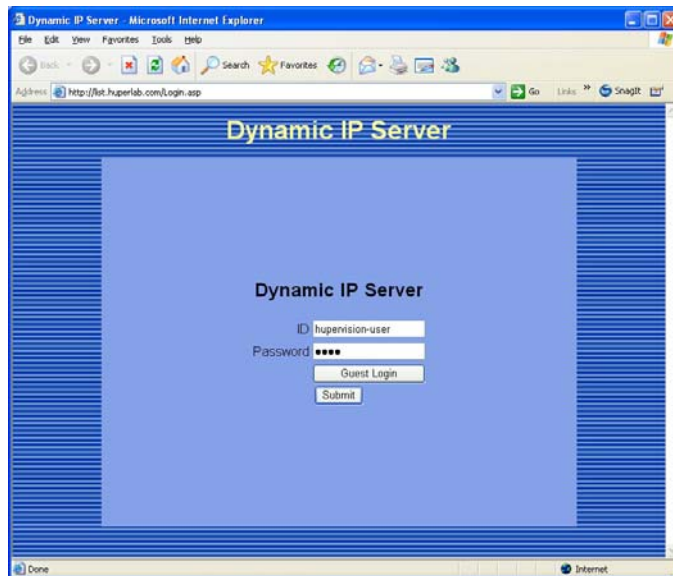

3. Click the button that opens the page where the available Web cameras that can be viewed are listed. For example, click the "Web Cam List" button.

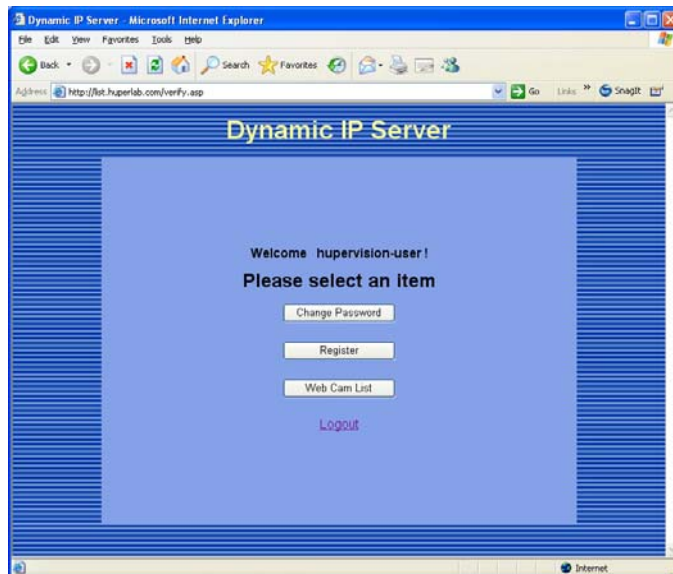

4. Click a site name from the list to open the Web page of the corresponding server site.

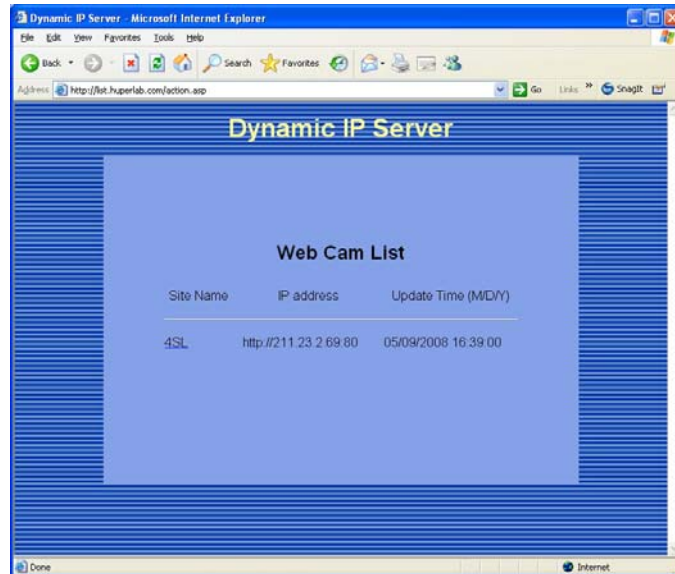

5. Use the navigation controls on the Web page to monitor the on-site cameras.

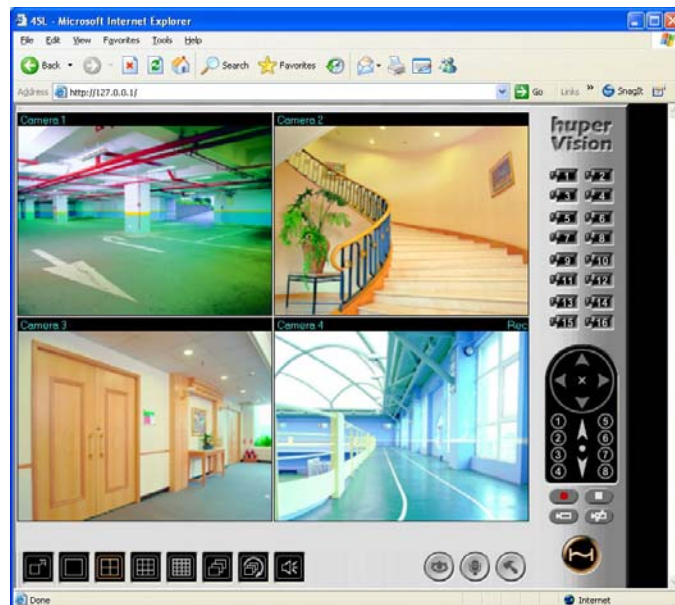

Notes:

- There is a free list server, www.dvr24h.com, that is available to the public.
- If the DVR system is in a LAN environment, you must set the router to forward port number 80 to the DVR system. Otherwise, clicking the DVR link in the Dynamic IP Server will not allow users to reach the DVR system.

User accounts (User tab)

In the User tab of the Preferences dialog box, you can create and manage user accounts, add new privilege levels, enable local or centralized control over Site Server, and enable automatic login access to the DVR server.

Note: Only user accounts with Administrator privilege level will have rights to access and change settings in the User tab.

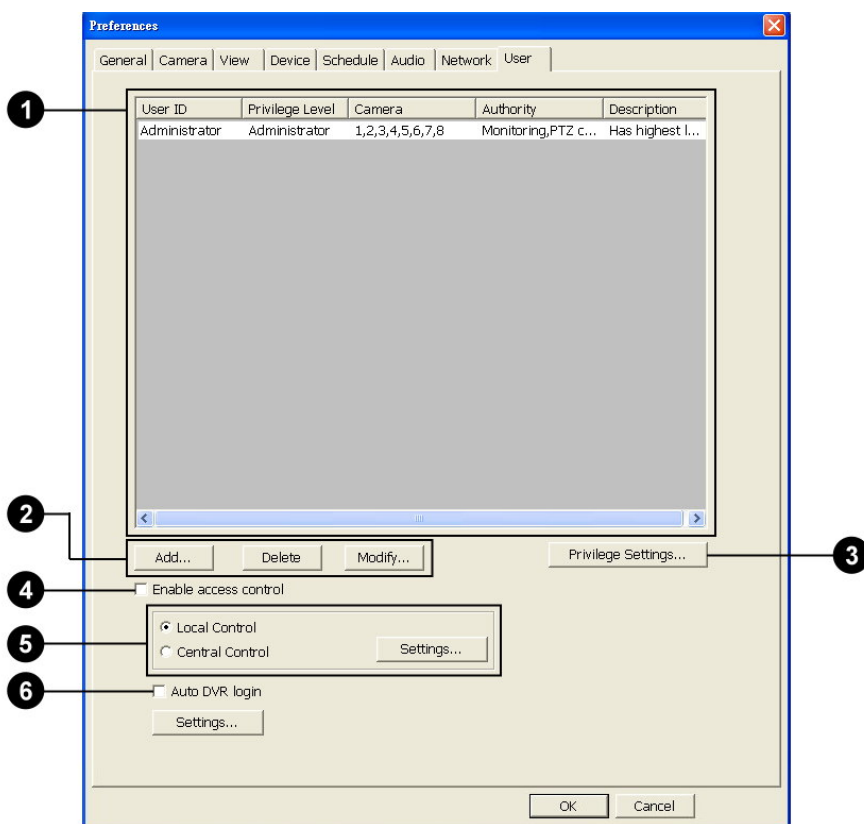

- 1** User account list This list shows the current user accounts that have been added to the Site Server. By default, an Administrator account is already added.
- 2** Add / Delete / Modify Click the corresponding button to create a new user account, delete an existing account, or change the user password, privilege level and other settings.

- 3** Privilege Settings Click this button to open the Privilege Level dialog box where you can add new privilege levels and assign allowed actions for each level. No new privilege level can be higher than the "Administrator" privilege.

- 4** Enable access control Select this option if you want to restrict the Site Server program's access rights only to users having the Administrator privilege. When access control is enabled, Site Server (as well as the other programs) will always prompt for the User ID and Password when the program is launched. (See "Launching the Site Server" for more details.)

- 5** Local / Central Control Select Local Control to maintain user accounts to be added and managed locally on the Site Server. Otherwise, select Central Control if you want all user accounts to be registered to the List Server, which acts as a central server for maintaining user data for all networked DVR systems.

Note: List Server can be installed and run at a separate computer or on the DVR system.

- 6** Auto DVR login Select this option if you want to allow only certain user accounts to login to the Site Server.

Refer to the succeeding sections for more details on the above-mentioned settings.

Creating and maintaining user accounts

To create a new user account:

1. In the User tab, click "Add". The Add User dialog box then appears.

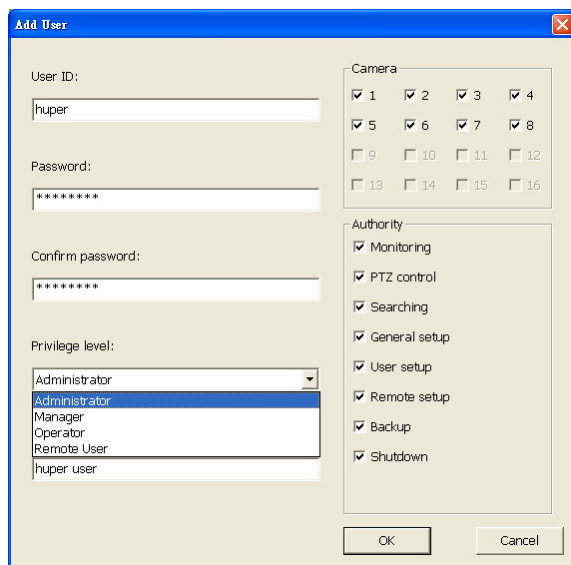

2. Enter a "User ID", and enter the "Password" twice in the provided text boxes.
3. Select a "Privilege level" to assign to the user account. (See table next page for details.)

User	Privilege
Administrator	Highest level of privilege. A user who is assigned with an "Administrator" privilege will be able to view all cameras, customize preference options, and add/delete/modify user accounts.
Manager	A user who is assigned with a "Manager" privilege can view cameras assigned with "Manager", "Operator" or "Remote user" privilege, but does not have rights to customize preference options.
Operator	A user who is assigned an operator privilege: <ul style="list-style-type: none"> ▪ Can view cameras that were assigned with "Operator" or "Remote user" privilege. ▪ Does not have access rights to the User tab in the Preferences dialog box. ▪ Does not have rights to modify preference settings of camera that were assigned with "Administrator" or "Manager" privilege.

Remote user	A user who is assigned with a "Remote user" privilege can only view cameras that were assigned with the same level of privilege remotely through a Web browser or remote viewer tool.
-------------	---

4. Enter a textual "Description" about the user account.
5. In the Camera group box, select the surveillance cameras that this user account will be permitted to have access.
If the privilege level assigned to this user account does not permit access to all cameras, the restricted cameras will be grayed out and cannot be selected in the Camera group box.
6. In the Authority group box, the permitted rights for performing certain actions will be selected by default for the chosen privilege level. (For instance, if you assigned the Administrator level in step 3, all rights will be selected. Whereas if you assigned the Remote User level, only Monitoring and PTZ control will be selected and the others will be grayed out.)

If you want to exclude some rights, deselect their checkboxes.

Note: See the section, "Adding privilege levels", for details on the types of rights and the set of actions that can be assigned to a privilege level.

To make changes to a user account:

1. In the User tab, select the user ID of the account that you want to modify.
2. Click "Modify", then make adjustments in the Modify User dialog box.

To delete a user account:

1. In the User tab, select the user ID of the account that you want to remove.
2. Click "Delete".

Adding privilege levels

As mentioned in the previous section, there are four default privilege levels: Administrator, Manager, Operator, and Remote User. If you want to add more privilege levels and assign them with different sets of actions, click the Privilege Settings button in the User tab. This will open the Privilege Level dialog box where you add, modify, delete, increase, or decrease privilege levels.

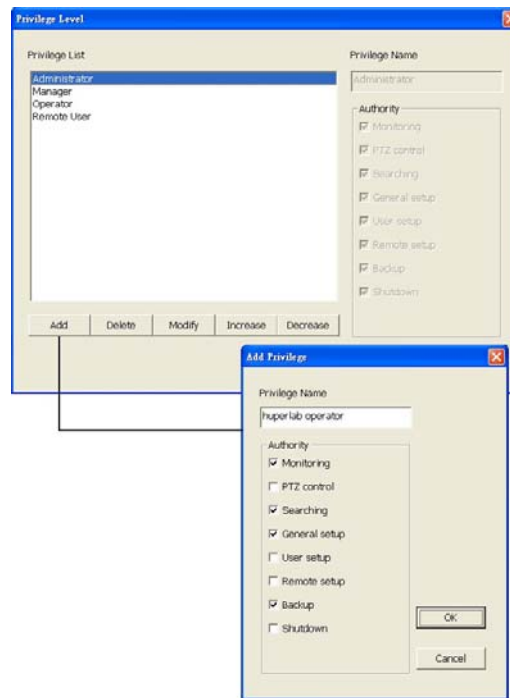

To create a new privilege level:

1. Click "Add" to open the Add Privilege dialog box.
2. Enter a name for the new privilege level.
3. In the Authority group box, select the checkboxes of those actions that you want to assign to this privilege level. (See the table below for details on each type of action.)
4. Click "OK".

Authority	Actions
Monitoring	View live camera video either on the local site or remote site.
PTZ Control	Control PTZ cameras. (Does not include rights to customize settings)
Searching	Perform any action on video recordings except for backup. It allows access to the Record Player, Remote Record Player, and huperRemote to play back video recordings.

General Setup	<ul style="list-style-type: none"> ▪ Modify settings on the Preferences dialog box of Site Server. In the Camera tab, only cameras that have lower or equal privilege levels to the login user are allowed to do modifications. ▪ Enable or disable detection on the Site Server. ▪ Modify settings on the detection dialog boxes of Site Server. ▪ Modify settings on the PTZ Control Panel. ▪ Adjust the brightness, contrast, hue, and saturation settings for cameras on the Site Server.
User Setup	Add, delete, or modify user accounts in Preferences - User tab.
Remote Setup	Use remote desktop control.
Backup	Run the Backup Scheduler program to modify settings and back up recordings.
Shutdown	Close the DVR Site Server program

Auto DVR login

The Auto DVR login option, when selected, allows only certain user accounts to log into and access the Site Server.

To allow a certain user account to have login access to Site Server:

1. First, create a user account by clicking the Add button in the User tab of the Preferences dialog box. See the section "Creating and maintaining user accounts" for details on how to create a new user account.
2. Select the Auto DVR login checkbox.
3. A message box then appears, reminding you that you need to specify the user account that will be allowed to log into the Site Server. Click OK.
4. The Auto DVR Login dialog box then appears. Enter the user ID and correct password twice, then click OK. (You can also click Settings to open the Auto DVR Login dialog box.)

Central Control and Local Control

By default, the "Central Control" option is selected which allows user account information to be registered in the centralized database of the List Server. (See Chapter 9 for more information.) With this option selected, new user accounts that you create will be added to the List Server.

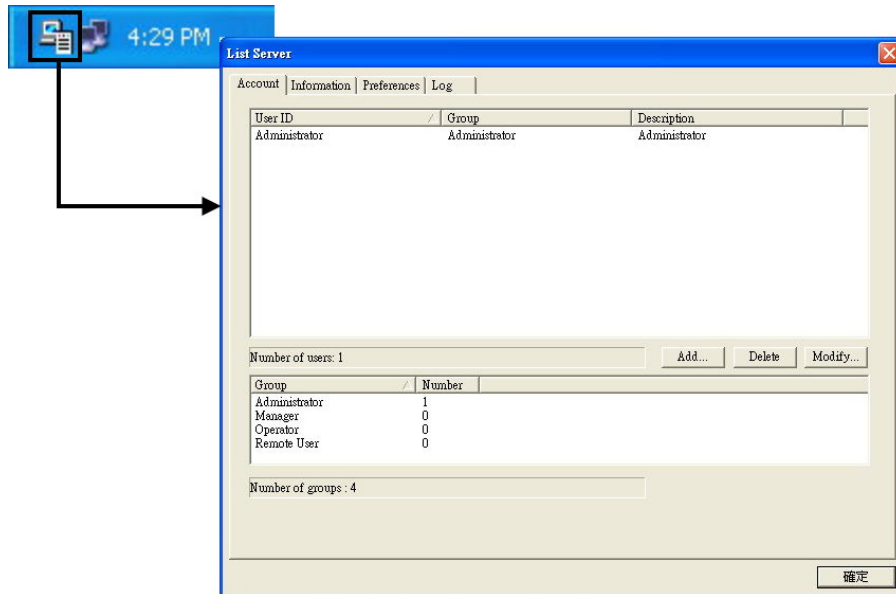

List Server can be installed and ran on a separate computer on your local network. If you have this type of set up, click Settings. The following dialog box will then be displayed:

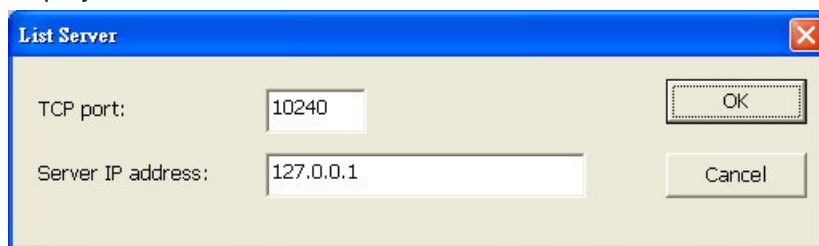



Specify the correct TCP port and TCP/IP address of the List Server computer in order for the Site Server program to connect to the List Server computer and to register user account information on that computer.

On the contrary, if you prefer the user account information to be added and maintained locally on the Site Server, select the "Local Control" option.

Note: The default user account for List Server is: User name: administrator, Password: system

Motion detection

Motion detection allows video cameras to detect the presence of movement. Basically, Site Server detects motion by comparing consecutive frames to see if there is any change between the frames. To enable this function, select the "Motion detection" option in the Camera tab of the Preferences dialog box, then click the Settings button to open the Motion Detection dialog box where you can set up what specific areas will be detected for the presence of motion. In this dialog box, you can adjust settings such as sensitivity level, noise tolerance, and more.

Note: If you clicked  in the Camera Operation Panel, click  to open the Motion Detection dialog box.

Marking areas to exclude from detection



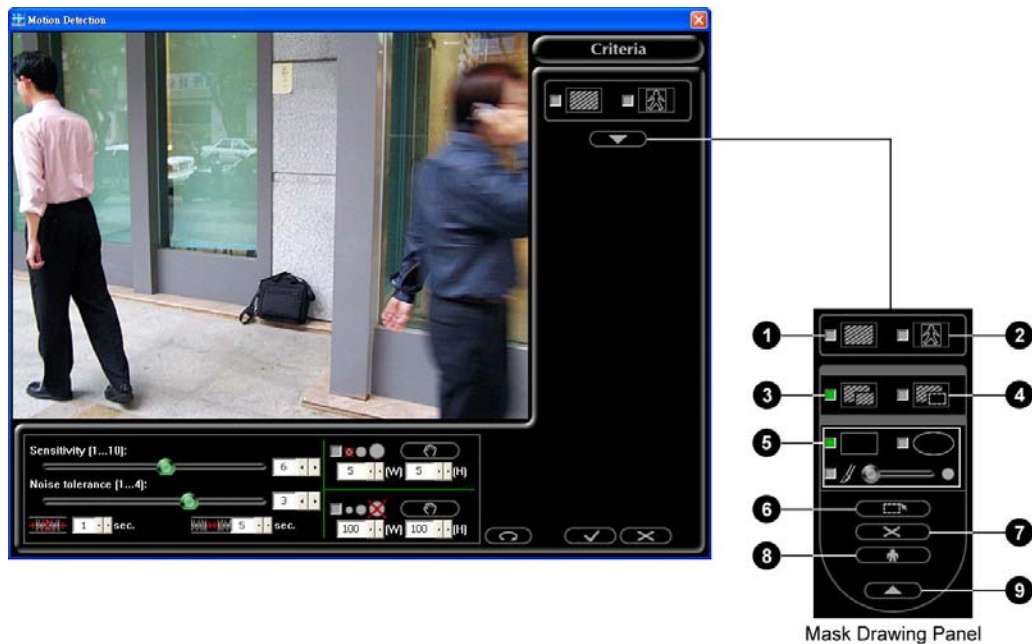







The first thing you need to do is to mask out irrelevant areas that will not be included in motion detection. Click  to expand the Mask drawing Panel. This panel contains button controls which allow you to mask out areas that will be excluded from detection.



1 Show mask



Select this option to display a mask (i.e., a shield) on the areas that will be excluded from detection.

- 2** Show tracking block  Select this option to display a rectangular box on areas that have been detected with motion.
- 3** Add mask  Select this option to add a mask. Use the drawing tools to draw the mask.
- 4** Subtract mask  To add back parts from a masked-out area and include them during detection, select this option. Use the drawing tools to erase the mask.
- 5** Drawing tools
- Rectangular mask  Select this tool to draw a rectangular-shaped mask. Drag your mouse over an area on the video to draw the mask.
- Elliptical mask  Select this tool to draw an elliptical -shaped mask. Drag your mouse over an area on the video to draw the mask.
- Draw by Brush  Select this tool to draw a freeform-shaped mask. Drag the slider to the right to have larger-size brush strokes, or drag to the left to have smaller-size strokes. To draw the mask, drag your mouse over an area on the video.
- 6** Mask All  Click this button to mask out the whole video and then switch to the Subtract-mask mode automatically.
- 7** Clear Masks  Click this button to erase all the masks and then switch to the Add-mask mode automatically.
- 8** Freeze Video  Click this button to freeze the live video.
- 9** Close Mask drawing Panel  Click to close the Mask drawing Panel.

Motion detection settings

To customize motion detection settings, adjust the controls at the bottom of the Motion Detection dialog box.

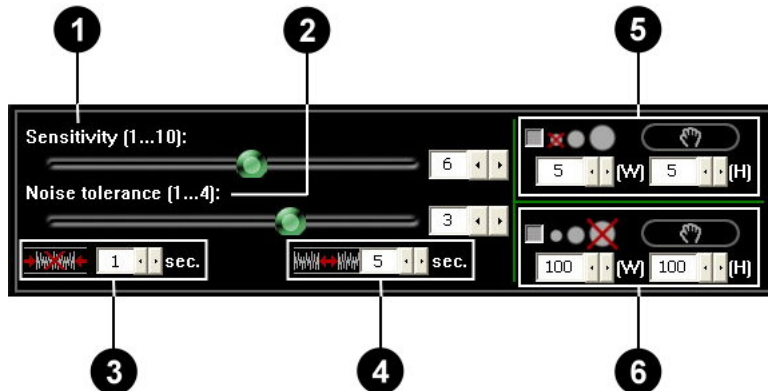

1 Sensitivity

Set the level of sensitivity to motion. Low sensitivity means that minimal motion will be ignored, and that only dramatic changes in movement will be detected. However, this may result in loss of event. High sensitivity means that even the smallest movement will be detected, but it could be a false event. Careful testing and fine tuning of the sensitivity setting is recommended.

2 Noise tolerance

Set the tolerance level to noise. Moving elements on the video whose pixel sizes are smaller than the specified noise tolerance level will be treated as video signal noise and will be ignored. This can reduce the occurrence of falsely detected motion caused by video signal noise in low illuminated environments.

3 Shortest event duration

Set the minimum time duration for each event. If the duration of a detected event is shorter than the defined shortest event duration, it will not be treated as an event.

4 Event interval

Specify the minimum interval between motion events.

5 Ignore smaller object

Select this option to filter out small objects (such as flashing stars in the sky or distant street lamps) whose dimensions are smaller than a specific size. To measure a large object to be used as the basis, click the Get button  then drag your mouse around that object. Its dimensions will then be displayed in the width and height boxes.

6 Ignore larger object

Select this option to filter out large moving objects (such as moving vehicles) whose dimensions are larger than a specific size. To measure a large object to be used as the basis, click the Get button  then drag your mouse around that object. Its dimensions will then be displayed in the width and height boxes.

Missing/left object detection

On a busy scene with lots of people and objects in motion such as in an airport or railway station, object detection can be applied. For instance, baggage left on the scene for a long period of time will seem suspicious, and you can use this function to track them. You can also use this function to detect if a static object has been moved out of the scene (such as a wall painting that has been stolen).

To enable this function, select the "Missing/left object detection" option under the Detect events by group box in the Camera tab of the Preferences dialog box, then click the Settings button to open the Missing & left object detection dialog box where you can set up what areas to detect for objects.

Marking areas to exclude from detection

Just like in motion detection, the first thing you need to do in object detection is to mask out irrelevant areas that will not be included in the detection process. Click  to expand the Mask drawing Panel that is on the right side of the dialog box. This panel contains button controls which allow you to mask out areas that will be excluded from detection. (These button controls are similar to the ones in the Motion Detection dialog box.)

Object detection settings

To customize object detection settings, adjust the controls at the bottom of the Missing & left object detection dialog box.





- 1** Minimum halt duration Specify the minimum time duration when objects are expected to remain on its location. If an object remains on its location longer than the defined duration, it may be treated as a suspicious object. If an object disappears from its location before the defined duration has elapsed, it may be treated as a stolen object.
- 2** Sensitivity Set the sensitivity level for detecting missing objects or objects that are left on the scene.
- 3** Ignore small object Select this option to exclude small objects whose dimensions are smaller than a specific size. The way to measure an object size is the same as in Motion detection's object size filtering.
- 4** Ignore large object Select this option to exclude large objects whose dimensions are larger than a specific size. The way to measure an object size is the same as in Motion detection's object size filtering.

Note: While Missing/left object detection is applied, the Sharpness level should be lower than 6.

Virtual fence detection

Through Virtual fence detection, you can set up one or more borderlines on a site where possible intrusions should be detected. You can also use this detection method to track moving objects that pass by in the wrong direction.

Follow these steps to create borderlines and set up Virtual fence detection:

1. Open the Preferences dialog box and click the Camera tab.
2. Select a camera for which you want to set up Virtual fence detection by clicking its camera number.
3. In the Detect events by group box, select the Virtual fence detection checkbox, then click the Settings button. The Virtual Fence Detection dialog box appears.
4. Click  to expand the drawing panel and reveal the complete button controls for setting up borderlines.
5. Click  to temporarily freeze the live video and make it easier for you to draw your borderline.
6. Click a starting point on the video, drag your mouse to draw a borderline, and then release the mouse when you reach the desired end point.
7. To skew the line, drag the end (yellow) point and adjust the line.

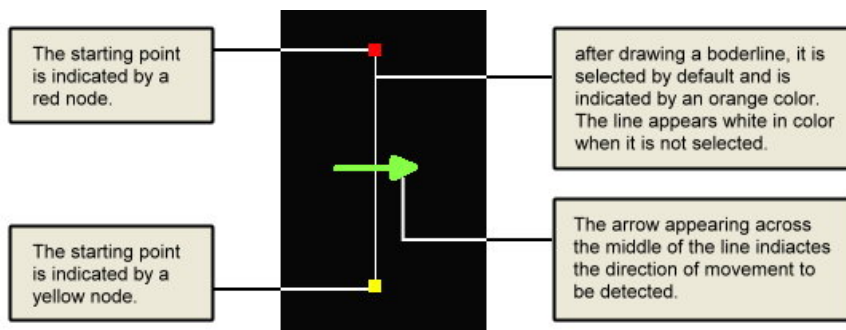



8. Use the other controls in the dialog box to give a name to the borderline, change the direction of movement, etc. For more details, see "Virtual fence detection controls and settings".
9. Repeat steps 6 to 8 to draw more borderlines on the video. You can add up to a maximum of 5 borderlines per camera video.
10. Click the Apply button  to apply the Virtual fence detection settings to the chosen camera.

Note: Virtual fence detection will be activated 6 to 7 seconds after the detection settings have been applied.

Virtual fence detection controls and settings



- 1** Display Line  Select this option to display borderline indicators that will allow you to see where on the camera video Virtual fence detection will be applied.
- 2** Show tracking block  Select this option to display a rectangular box around the detected objects that have crossed the borderlines.
- 3** Line name This shows a default name given to a borderline. Each borderline you created will be indicated by a sequential number in the line name. You can change the line name by entering your desired name in the text box.

4 Movement direction



Select a borderline that you created, then click this button to set the direction of object movement to be detected. There are three directions of movement to choose from:

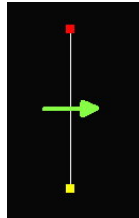

Left to Right

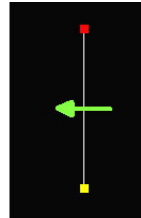

Right to Left

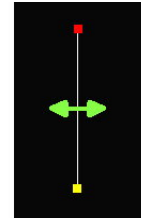

Bidirectional

5 Delete line



Select an unwanted borderline on the video window then click this button to delete it.

6 Delete all lines



Click this button if you want to remove all borderlines and start all over.

7 Freeze Video



Click this button to freeze the live video.

8 Close drawing panel



Click this button to close the drawing panel.

9 Event duration

When a moving object crosses a borderline in the specified direction, the line will repeatedly flash in red as an indication that a Virtual fence detection event has occurred. You can set the length of time that the line flashes by adjusting the Event duration. This value also determines the duration for event-related operations such as event recording and playback.

10 Sensitivity

Set the level of sensitivity to moving objects. Drag the slider to the left if you want to set a lower sensitivity level or to the right to set a higher sensitivity. High sensitivity means that even the smallest movement will be detected, but it could be a false event. Careful testing and fine tuning of the sensitivity setting is recommended.

- 11 Ignore smaller/
larger object

Select these options to enable size filtering for moving objects. You can specify what sizes of objects to ignore and exclude from Virtual fence detection.

The way to set up object size filtering in Virtual fence detection is just the same as in Motion detection. For details, see "Motion detection settings" in this chapter.

- 12 Reset



Click to load back the default settings.

- 13 Apply



Click to apply the modified settings.

- 14 Cancel





Click this button if you change your mind and do not want to apply the modified settings. The Virtual fence detection dialog box then closes and reuses the previous settings.

Secure zone detection

Through Secure zone detection, you can specify one or more areas on a site that people are not allowed to enter. You can also use Secure zone detection to detect whether there are objects that try to occupy restricted zones, for instance, vehicles that are parked in forbidden places.

Follow these steps to mark areas and set up Secure zone detection:

1. Open the Preferences dialog box and click the Camera tab.
2. Select a camera for which you want to set up Secure zone detection by clicking its camera number.
3. In the Detect events by group box, select the Secure zone detection checkbox, then click the Settings button. The Secure Zone Detection dialog box appears.
4. Click  to expand the drawing panel and reveal the complete button controls for setting up areas to be monitored.
5. Click  to temporarily freeze the live video and make it easier for you to mark areas on video.
6. Click a starting point on the video, drag your mouse to draw a rectangular box over a forbidden area, and then release the mouse when you have completely boxed the area. After drawing a box, it is by default selected and appears in orange. A box appears in white when it is not selected.
7. Click a starting point on the video, drag your mouse to draw a rectangular box over a forbidden area, and then release the mouse when you have completely boxed the area.

Note: To select a rectangular box that you created, click any of the sides of the box, or hold the [Alt] key and click the marked area inside the box.

8. Use the other controls in the dialog box to give a name to the rectangular box or delete it. For more details, see "Secure zone detection controls and settings".
9. Repeat steps 6 to 8 if you want to mark more areas with rectangular boxes. You can mark up to a maximum of 5 areas per camera video.
10. Click the Apply button  to apply the detection settings to the chosen camera.

Secure zone detection controls and settings

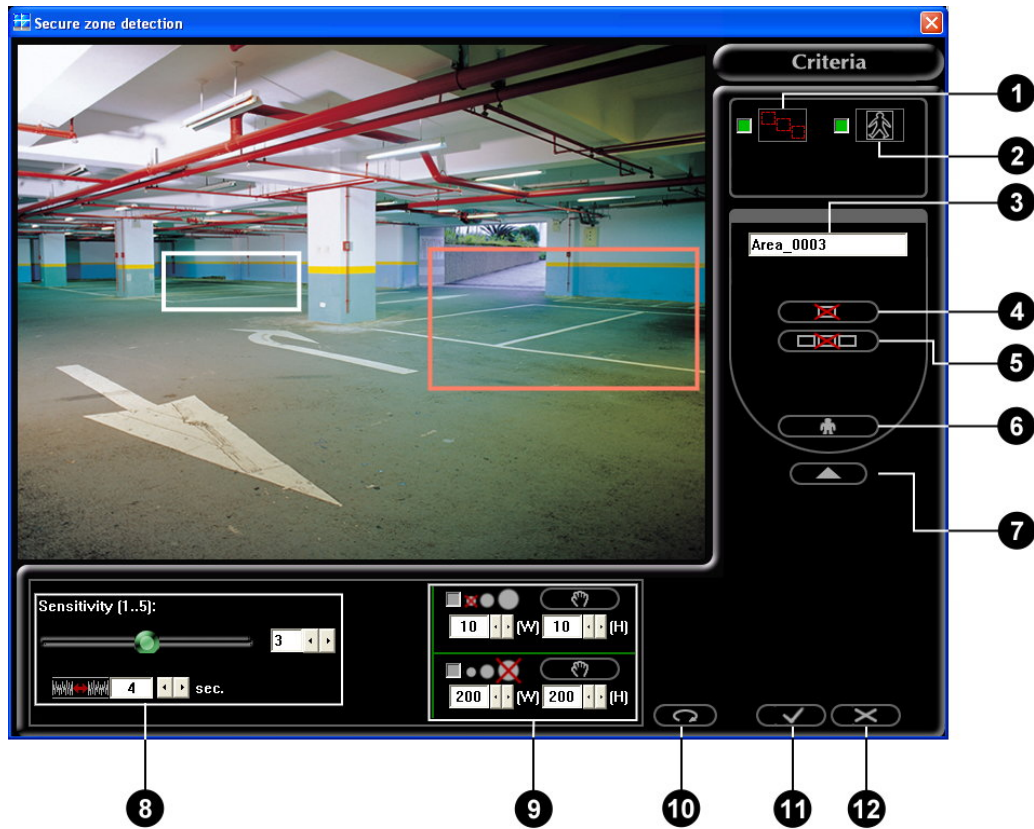

- 1

Display forbidden area



Select this option to display rectangular box indicators that will allow you to see which areas on the camera video are marked and will be applied with Secure zone detection.
- 2

Show tracking block



Select this option to display a tracking box around the people or objects that have been detected to have entered or occupied the forbidden areas.
- 3







Box name

This shows a default name given to a rectangular box. Each box you created will be indicated by a sequential number in the box name. You can change the box name by entering your desired name in the text box.
- 4

Delete box



Select an unwanted box on the video window then click this button to delete it.

- | | | | |
|-----------|--------------------------------|---|---|
| 5 | Delete all boxes |  | Click this button if you want to remove all boxes and start all over. |
| 6 | Freeze Video |  | Click this button to freeze the live video. |
| 7 | Close drawing panel |  | Click this button to close the drawing panel. |
| 8 | Sensitivity and Event duration | | Set the level of sensitivity to objects, and set the duration for displaying flashing boxes around marked areas when an intrusion in these forbidden areas has been detected. |
| 9 | Ignore smaller/larger object | | Select these options to enable size filtering for objects. You can specify what sizes of objects to ignore and exclude from Secure zone detection. The way to set up object size filtering in Secure zone detection is just the same as in Motion detection.
For details, see "Motion detection settings" in this chapter. |
| 10 | Reset |  | Click to load back the default settings. |
| 11 | Apply |  | Click to apply the modified settings. |
| 12 | Cancel |  | Click this button if you change your mind and do not want to apply the modified settings. The Secure zone detection dialog box then closes and reuses the previous settings. |



Flow counting

Just like Virtual fence detection, Flow counting allows you to specify borderlines on a site and detect for moving objects that pass through these lines. The only difference is, the Flow counting method also counts the number of objects that pass through the borderlines.

For each borderline, you can set the direction that you want to detect for moving objects. You can set the direction to be Flow-in only, Flow-out only, or Bi-directional flow.

Flow counting can only be applied on cameras that have been set with either Non-stop Recording or Non-stop Smart Recording.

Follow the steps below to create borderlines and set up Flow counting:

1. Open the Preferences dialog box and click the Camera tab.
2. Select a camera for which you want to set up Flow counting by clicking its camera number.
3. In the Detect events by group box, select the Flow counting checkbox, then click the Settings button. The Flow Counting dialog box appears.
4. Click  to expand the drawing panel and reveal the complete button controls for setting up borderlines.
5. Click  to temporarily freeze the live video and make it easier for you to draw your borderline.
6. Click a starting point on the video, drag your mouse to draw a borderline, and then release the mouse when you reach the desired end point.
7. Enter a name for the borderline, see "Flow counting controls and settings".
8. To set the direction of the borderline, click . Keep on clicking this button until you have set the direction that you want. A colored arrow will be displayed in the middle of the borderline to indicate the selected direction:

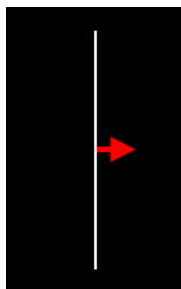

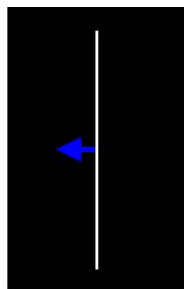

Red arrow indicates Flow-in

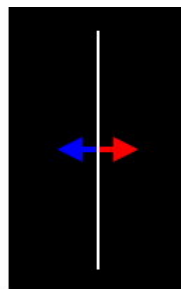

Blue arrow indicates Flow-out









Bidirectional arrow indicates both Flow-in and Flow-out

9. You can customize more settings in the dialog box. Refer to "Flow counting controls and settings" for details.
10. Repeat steps 6 to 8 to draw another borderline on the video. You can add up to a maximum of 2 borderlines per camera video.
11. Select a borderline by clicking it. When selected, it appears orange in color. If you want to move a borderline, drag it to the desired position. When a borderline is not selected, it appears white in color.
12. You can test Flow counting on the borderlines that you created. Click  to first unfreeze the live video, and then do your test by moving any object several times across the borderlines on the video. You will see the counted numbers in the Line1 and Line2 text boxes.
13. Click the Apply button  to apply your settings to the chosen camera.

Flow counting controls and settings





- | | | |
|-------------------------------|---|--|
| 1 Display Line |  | Select this option to display borderline indicators that will allow you to see where Flow counting will be applied on the camera video. |
| 2 Show tracking block |  | Select this option to display a rectangular box around the detected objects that have crossed the borderlines. |
| 3 Line name | | This shows a default name given to a borderline. Each borderline you created will be indicated by a sequential number in the line name. You can change the line name by entering your desired name in the text box. |
| 4 Movement direction |  | Select a borderline that you created, then click this button to set the direction of object movement to be detected. There are three directions of movement that you can choose from: Flow-in only, Flow-out only, or Bi-directional fbw. |
| 5 Delete line |  | Select an unwanted borderline on the video window then click this button to delete it. |
| 6 Delete all lines |  | Click this button if you want to remove all borderlines and start all over. |
| 7 Freeze Video |  | Click this button to freeze the live video. |
| 8 Close drawing panel |  | Click this button to close the drawing panel. |
| 9 Line 1 (in vs. out) | | When you test Flow counting in the dialog box, the text boxes here will show the number of detected objects that passed through the first borderline. The left text box shows the number of objects that flowed in, and the right text box shows the number of objects that flowed out. |
| 10 Line 2 (in vs. out) | | When you test Flow counting in the dialog box, the text boxes here will show the number of detected objects that passed through the second borderline. The left text box shows the number of objects that flowed in, and the right text box shows the number of objects that flowed out. |

- 11** Reset interval

Set the interval between counter resets. For instance, if you enter 60 minutes, the counter will reset to zero after every hour.
- 12** Sensitivity

Set the level of sensitivity to moving objects. Drag the slider to the left if you want to set a lower sensitivity level or to the right to set a higher sensitivity.
- 13** Ignore smaller/larger object

Select these options to enable size filtering for moving objects. You can specify what sizes of objects to ignore and exclude from detection. The way to set up object size filtering in Flow counting is just the same as in Motion detection. For details, see "Motion detection settings" in this chapter.
- 14** Restart fbw counting 

Click this button to reset the counters back to zero and start new counting session.
- 15** Reset 

Click to load back the default settings.
- 16** Apply 

Click to apply the modified settings.
- 17** Cancel 

Click this button if you change your mind and do not want to apply the modified settings. The Flow Counting dialog box then closes and reuses the previous settings.

On a split screen that shows camera video that has been applied with Flow counting, you can right-click on the split screen to open a pop-up menu. On the menu, click Reset Flow Counting when you want to reset the counter back to zero.

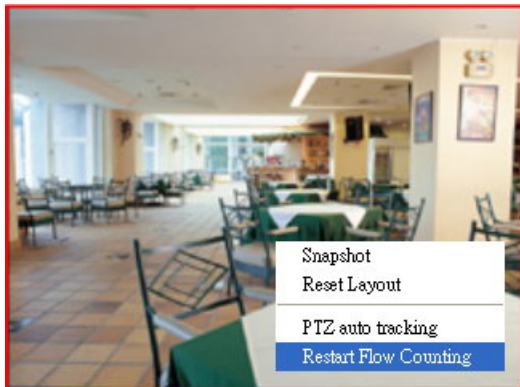

Flame detection

Flame detection sends immediate notifications when flames or flame-like flashes are detected.

Initially, a region or an object in a site that is suspected to be burning in flames or producing flame-like flashes will be detected and marked with a yellow frame (see sample image below).



After the flame-like flashes are identified as true flames, the region or object of interest will then be marked with a red frame.





To increase the accuracy of flame detection, a simple environment without too many scene changes is recommended to apply the flame detection feature. Also, decrease the iris level of cameras to increase the accuracy of flame detection.





Note: The camera might not be able to identify ordinary objects after the iris level is decreased.

To apply Flame detection, select the "Flame detection" option under the Detect events by group box in the Camera tab of the Preferences dialog box, then click the Settings button to open the Flame Detection dialog box where you can set up how to detect for flames or flame- like flashes.

The Flame Detection dialog box



- 1** Show yellow tracking block  Select this option to display a yellow frame around suspected flames or flame-like flashes.
- 2** Show tracking block  Select this option to display a red frame box around areas or objects that have been identified to be burning in flames.

- | | | |
|----------------------------------|---|--|
| 3 Expand drawing panel |  | Click this button to expand the Mask-drawing Panel. This panel contains button controls which allow you to mask out to irrelevant areas that will not be included in the detection process. (These button controls are similar to the ones in the Motion Detection dialog box. For more information, see "Marking areas to exclude from detection" earlier in this chapter.) |
| 4 Shortest event duration | | Set the minimum time duration for each event. If the duration of a detected event is shorter than the defined shortest event duration, it will not be treated as an event. |
| 5 Event interval | | Specify the minimum interval between events. |
| 6 Noise tolerance | | Adjust the noise tolerance level to reduce false alarms caused by video noises. The higher the tolerance level is, the less the interference of video noises. However, the sensitivity level will be reduced as well. |
| 7 Sensitivity | | Set the level of sensitivity to flames. The higher the sensitivity level is, the more sensitive the flame detection is. |
| 8 Reset |  | Click this button to load back the default settings. |
| 9 Apply |  | Click this button to apply the modified settings. |
| 10 Cancel |  | Click this button if you change your mind and do not want to apply the modified settings. The Flame Detection dialog box then closes and reuses the previous settings. |



People Counting

Just like Flow counting detection, People counting allows you to specify a detection area and detect for moving people that pass through the area. The only difference is, the Flow counting method counts the number of objects that pass through the borderlines while People counting counts the number of persons that pass through the detection area.

People counting will determine counting direction as left-right or up-down automatically according to location and drawing shape of detection area. For each detection area, you can set the direction that you want to detect for moving people. You can set the direction to be left to right (down to up), right to left (up to down), or Bi-directional.

People counting can only be applied on cameras that have been set with either Non-stop Recording or Non-stop Smart Recording.

Follow the steps below to create detection area and set up People counting:

1. Open the Preferences dialog box and click the Camera tab.
2. Select a camera for which you want to set up People counting by clicking its camera number.
3. In the Detect events by group box, select the People counting checkbox, then click the Settings button. The People counting dialog box appears.
4. Click  to expand the drawing panel and reveal the complete button controls for setting up detection area.
5. Click  to temporarily freeze the live video and make it easier for you to draw your detection area.
6. Click a starting point on the video, then drag your mouse to draw a detection area.
7. To set the counting direction of the detection area, click . Keep on clicking this button until you have set the direction that you want. A colored arrow will be displayed in the middle of the detection area to indicate the selected direction:

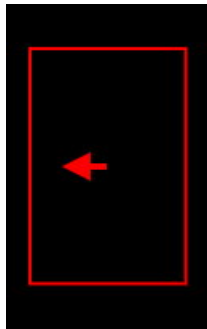

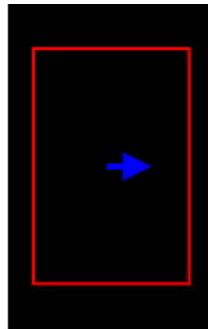

Red arrow indicates counting people from right to left (down to up)

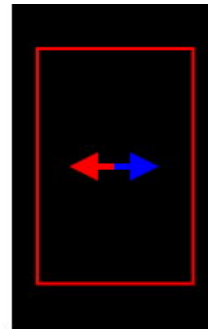

Blue arrow indicates counting people from left to right (up to down)





Bidirectional arrow indicates counting people from right to left & left to right (up to down & down to up)

8. You can customize more settings in the dialog box. Refer to "People counting controls and settings" for details.
9. Click  to remove detection area if you want to change the location of detection area. Repeat steps 6 to 8 to draw another detection area on the video.
10. Click the Apply button  to apply your settings to the chosen camera.
11. You can test People counting on the detection area that you created. Click  to first unfreeze the live video, and then do your test by making people moving several times across the detection area on the video. You will see the counted numbers in the detection area.

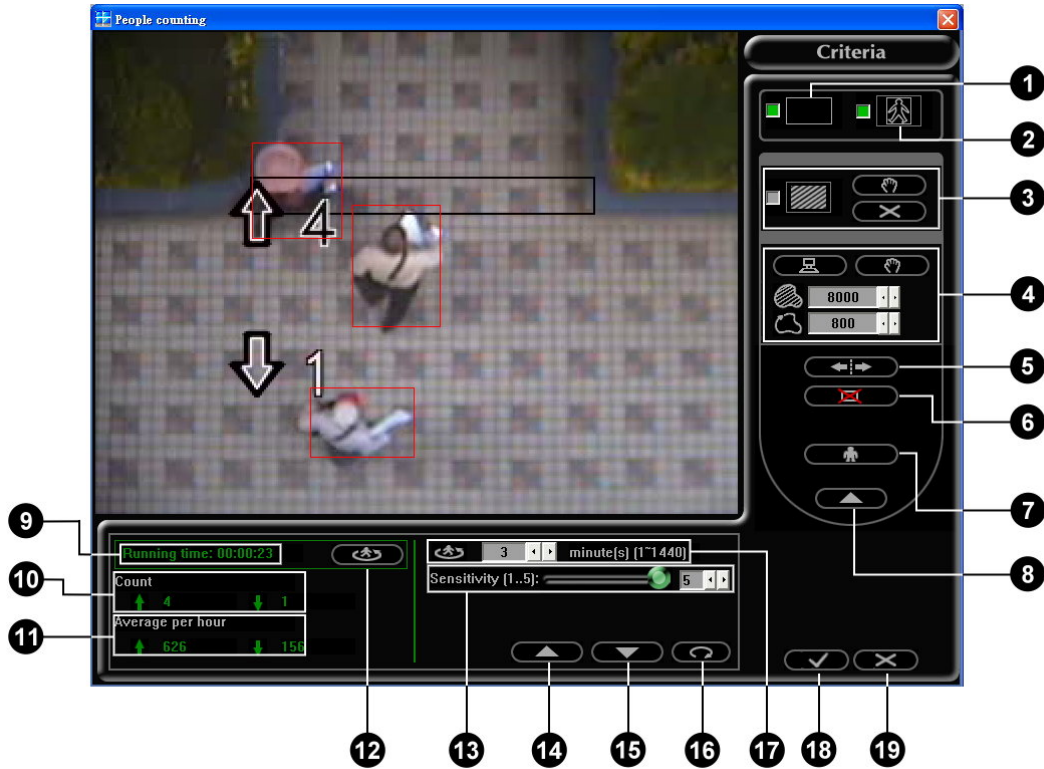
People counting controls and settings













- 1** Display counting area  Select this option to display borderline indicators that will allow you to see where People counting will be applied on the camera video.
- 2** Display object  Select this option to display a rectangular box around the detected objects that have crossed the borderlines.
- 3** Mask operation





Use the following options to complete mask area.

Enable/disable mask  Select this option to display a mask (i.e., a shield) on the areas that will be excluded from detection.

Set masks  Select this button to switch to add mask mode. Dragging mouse to add mask area..

Clear all masks  Click this button to erase all the masks.

- 4** Single person size settings
- Use the options below to set single person size parameters of detection.
- Get parameters automatically  Click this button to switch to automatic setting mode. It will calculate the single person parameters with passengers in the video.
- Get parameters manually  Click this button to switch to manual setting mode. Dragging rectangle in the video to set the single person parameters.
- Pixel amount  Object area size
- Counter length  Object area counter length
- 5** Counting direction  Select detection area that you created, then click this button to set the counting direction. There are two directions of movement that you can choose from: right to left (down to up) or left to right (up to down).
- 6** Delete detection area  Click this button if you want to remove detection area and start all over.
- 7** Freeze Video  Click this button to freeze the live video.
- 8** Close drawing panel  Click this button to close the drawing panel.
- 9** Running time
- The period of time after start counting
- 10** Count
- Current counting result with direction
- Note: The displayed direction is the same as current counting direction.
- 11** Average per hour
- Current counting result per hour with direction
- 12** Restart people counting  Click this button to reset the counters back to zero and write result to log file.
- 13** Sensitivity
- Set the level of sensitivity to moving objects. Drag the slider to the left if you want to set a lower sensitivity level or to the right to set a higher sensitivity.

- | | | | |
|-----------|-------------------|---|---|
| 14 | Overcount |  | Click this button to adjust single person size parameters if the counting result is over estimation. |
| 15 | Undercount |  | Click this button to adjust single person size parameters if the counting result is under estimation. |
| 16 | Reset |  | Click to load back the default settings. |
| 17 | Statistics period | | Set the looping period of time in minutes. It will reset the counters back to zero and write result to log file, then restart counting again when the setting time is up. |
| 18 | Apply |  | Click to apply the modified settings. |
| 19 | Cancel |  | Click this button if you change your mind and do not want to apply the modified settings. The People Counting dialog box then closes and reuses the previous settings. |

Wide dynamic vision

Wide dynamic vision is an extremely useful feature for enhancing the camera video quality to increase visibility in the event recordings, especially during the nighttime or when recording under darkly lit environments. This feature also allows you to filter out insignificant moving objects to reduce false alarms.



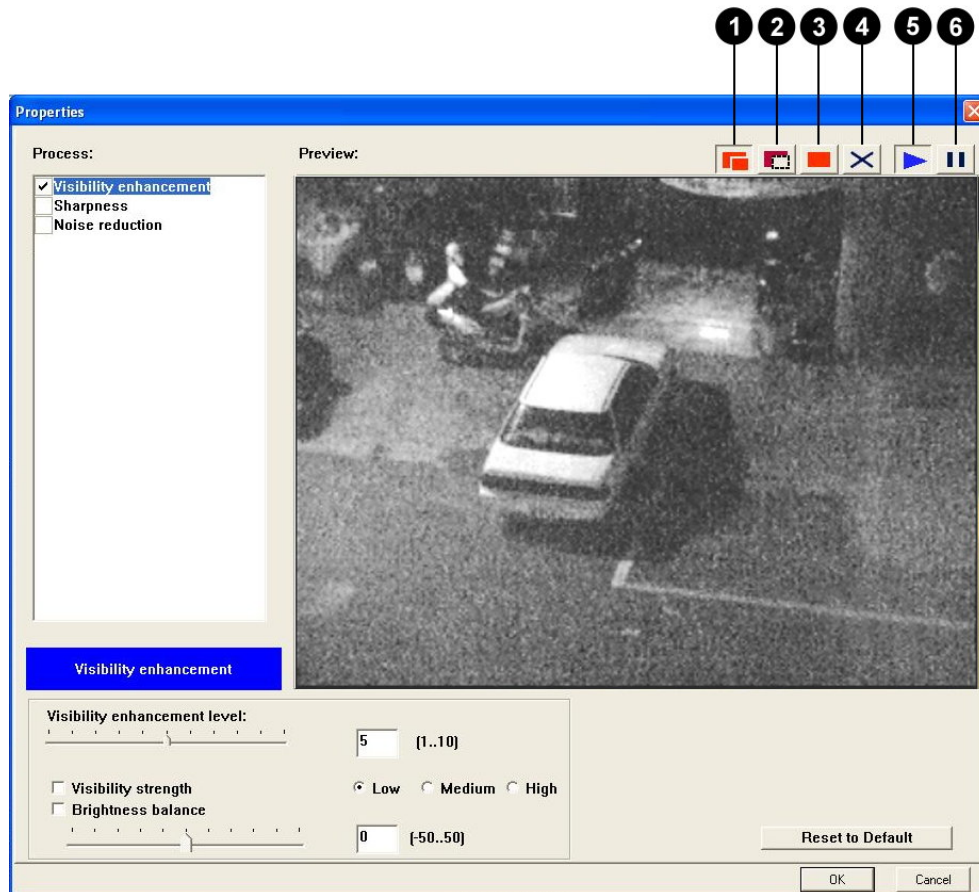

To enable this feature, select the Wide dynamic vision option in the Camera tab of the Preferences dialog box. Then click the Settings button to open the Properties dialog box where you can mask out insignificant areas or objects and adjust video enhancement settings.

Marking insignificant areas

Use the button controls on the top right corner of the Properties dialog box to mask out insignificant areas or objects on the scene.



- 1** Add mask  To detect motion on certain areas only, mask out the unwanted areas. Masking out these areas will exclude them from motion detection.

Click  then drag your mouse over the area that you want to mask out.
- 2** Delete mask  To add back parts from a masked-out area and include them during motion detection, click  then drag your mouse over the part that you want to add back.
- 3** Mask All  Click this button to mask out the whole camera view.
- 4** Clear All  Click this button to remove all masked selections and include them back during motion detection.

5 Play



By default, the "Play" button is pressed and live video is displayed at a frame rate of one frame per second on the preview window.

6 Pause



Click this button to freeze the video.

Visibility enhancement

Select the checkbox of this item to brighten the video during nighttime when the monitored site is dark and does not have sufficient lighting.

There are different situations wherein the lighting conditions may be insufficient. Follow the guidelines below to make adjustments under different conditions.

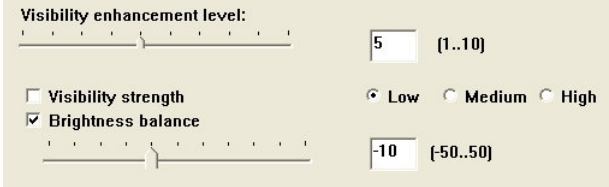
Environmental Situations	Solutions
Low lighting environment	<p>Adjust the Visibility enhancement level. (Setting the value to 6 or lower is recommended).</p> 
With static light sources in low lighting environment	<p>Solution 1:</p> <ol style="list-style-type: none"> 1. Adjust the Visibility enhancement level. (Setting the value to 6 or lower is recommended) 2. Select the Brightness balance adjustment option and adjust its value. Or, if the video quality is not good enough, select the Visibility enhancement option and choose a level.
With static light sources in low lighting environment	<p>Solution 2:</p> <ol style="list-style-type: none"> 1. Adjust the Visibility enhancement level. (Setting the value to 6 or lower is recommended). 2. Mask out background light such as lamp posts or reflected light. Or, if you want to get a better result of a certain area only, mask out the unwanted areas first so that Visibility enhancement will only be applied to the area of interest.

With moving light Sources in low lighting environment	<ol style="list-style-type: none">1. Adjust the Visibility enhancement level. (Setting the value to 6 or lower recommended).2. Select the Brightness balance adjustment option and choose a positive value. Or, if the video quality is not good enough, select the Visibility enhancement option and choose a level.
Back-lighted environment	<ol style="list-style-type: none">1. Adjust the Visibility enhancement level. (Setting the value to 6 or lower is recommended)2. Select the Brightness balance adjustment option and choose a positive value.
Overexposure under lighting conditions	<ol style="list-style-type: none">1. Adjust the Visibility enhancement level. (Setting the value to 6 or lower is recommended)2. Select the Brightness balance adjustment option and choose a negative value.

Note: The minimum illumination for a camera is very important to make Visibility enhancement most effective. In general, 0.1 LUX or below is recommended.

Sharpness

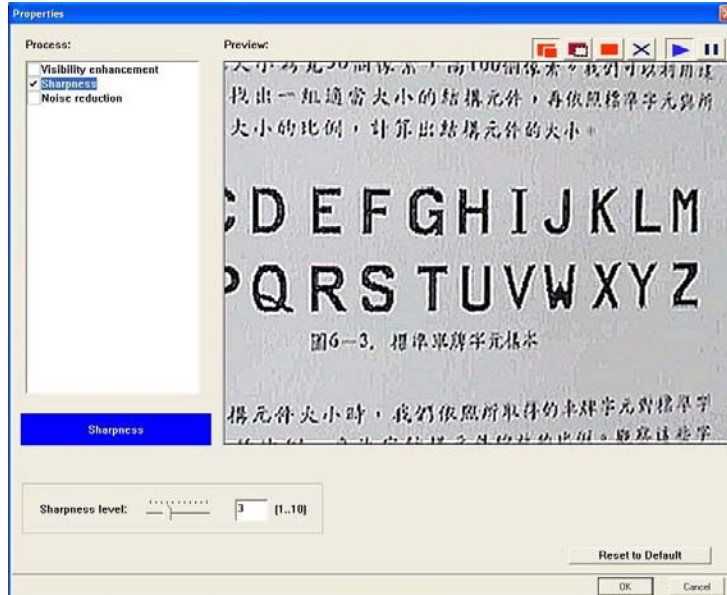

Select the checkbox of this item to enable sharpness enhancement. This helps sharpen edges of, for instance, a blurred background (that may be due to loss of focus).

Drag the Sharpness level slider to the right to increase sharpness; drag the slider to the left to decrease sharpness or blur the video.

Noise Reduction

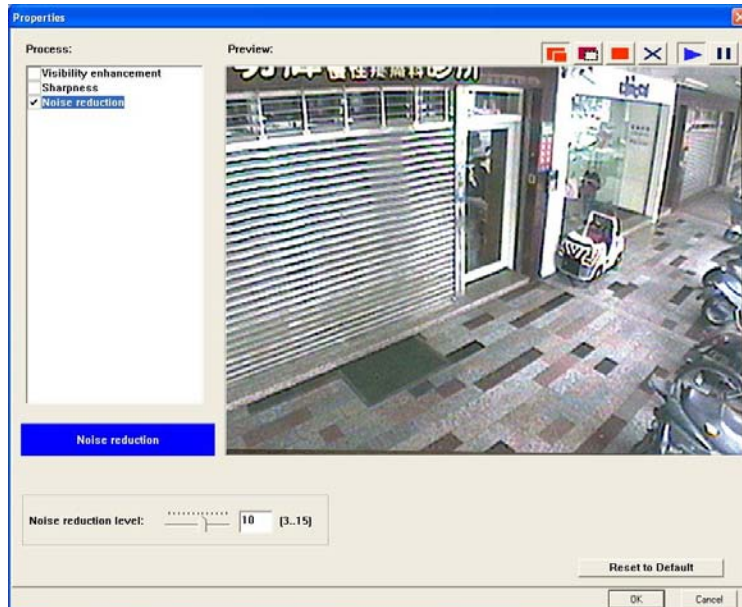

Select the checkbox of this item to enable noise reduction. This helps eliminate video noise that comes from the camera, and also reduces noise in dark scenes or nighttime environment. If you enabled Visibility enhancement, there may also be noise that is introduced to the video which can be minimized via noise reduction.

Adjust the Noise reduction level slider to control the extent of noise reduction to be applied to the camera video.

Note: When Noise reduction is enabled, it also reduces the size of recorded video.

Viewing logs and disk usage information

Use the following button controls to check recorded logs of events and inspect the hard disk storage space in the server computer that runs Site Server.

New Event Information

Clicking this button opens the Event Log dialog box which keeps a detailed log of events that have been detected.

The New tab, by default, shows a list of all events that were detected in the last 24 hours.

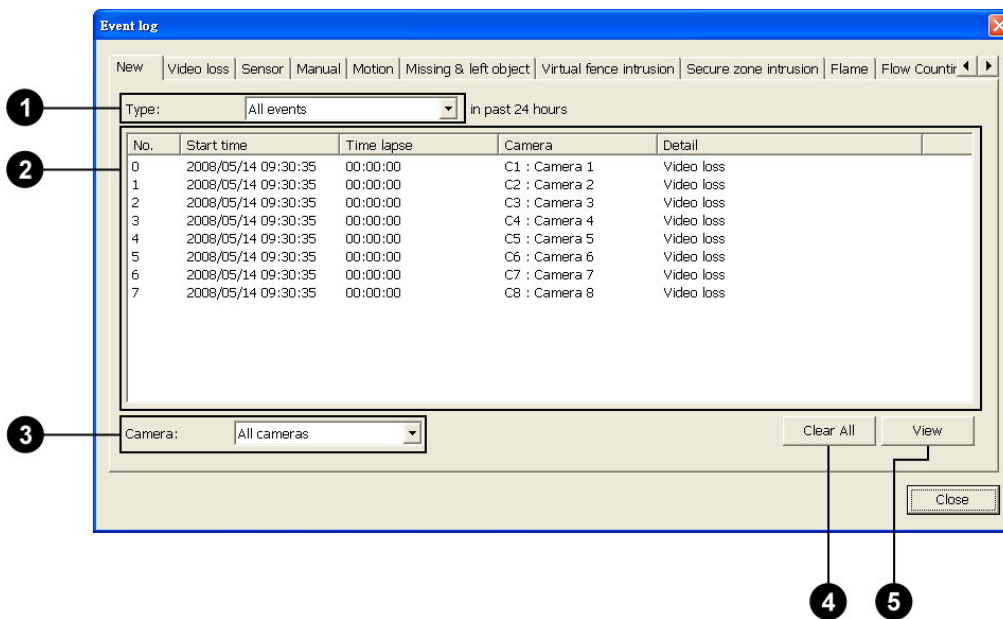

- 1** Type If you want to view only the logs of one type of event such as Motion event, select it from the Type list.
- 2** Log list The Log list shows details about each event, such as the start and end times of the event, camera number (indicated by C1 - C16) or sensor number (indicated by S1 - S16) that detected the event, type of event, etc.
- 3** Camera If you want to view only the logged events of one camera, select the camera number from the Camera list.

- 4** Clear All Click this button to delete all event logs from the list. These events are not deleted from the record database.
- 5** View Click this button to launch the Event Viewer program and play back a selected event. Not all events contain video recordings.

Click any of the other tabs in the Event Log dialog box to view only logged events of a particular type of event. For instance, click the Video Loss tab if you want to see only the list of cameras that were logged due to loss of video signal.

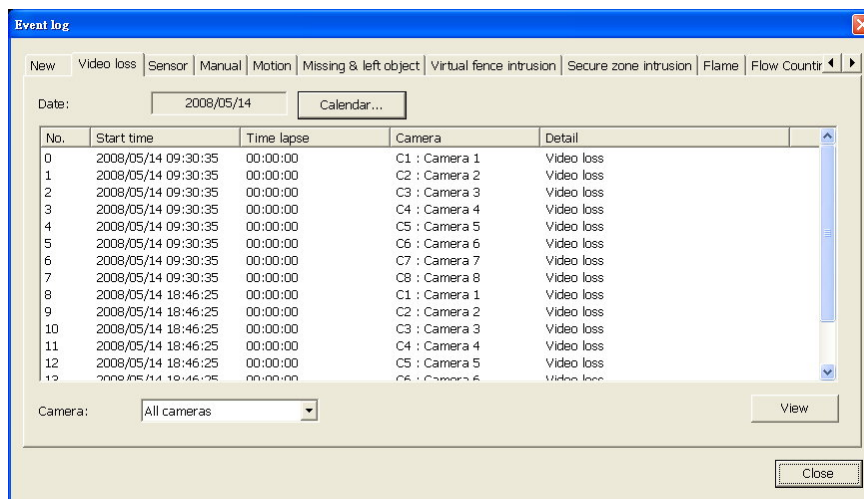

If you want to view logged events of another date, you can click the Calendar button to select the desired date.

Flow counting events of each camera are logged separately in different subfolders. Under C:\Program Files\huperlab\huperVision\FlowCountData, a subfolder for each camera is named using the convention, CameraNN, where NN represents the camera number. (This is assuming that the huperVision suite is installed in C:\Program Files\huperlab\huperVision).

Flow counting event logs are saved in .CSV (Comma Separated Value File) format, which is a popular database format. You can open the file and view the logs using software such as Microsoft Excel.

A new CSV file is created per day for each camera that records Flow counting events. The following is a sample CSV file.

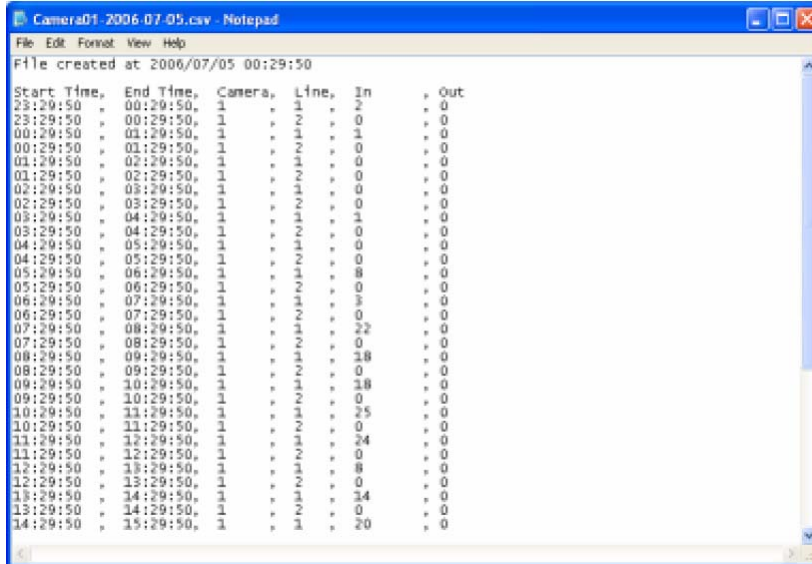

Storage Information 99.05%

This button displays the amount of remaining disk space. Click this button to open the Storage Information dialog box and view details on disk usage.

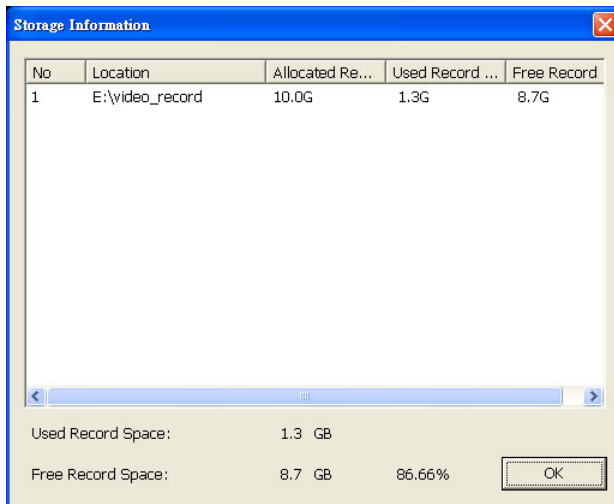

Operation Logs

Site Server records login/logout sessions, preferences modification date and time, as well as date and time logs of connections from remote sites. To view these operation logs, first click  on the Site Server program screen. Then, in the pop-up menu, click Operation Log to open the Logs dialog box.

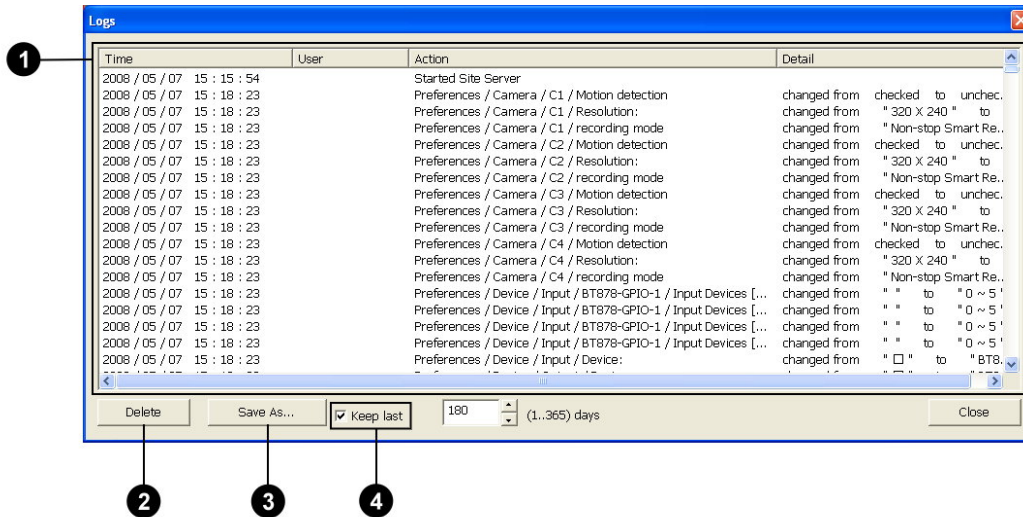

- 1** Log list The Log list shows the date and time, user account name, and the action performed.
- 2** Delete Click this button to delete all recorded logs. Only users with "administrator" privileges have rights to delete operation logs.
- 3** Save As Click this button to save operation logs as a text file.
- 4** Keep as Select this option and specify how many days of operation logs to maintain. This enables Site Server to purge old logs after the specified number of days and free up disk space.

Chapter 3

Record Player

Record Player lets you retrieve and view videos that have been digitally recorded by Site Server. It lists history records by time segments or by the actual occurrence of events. At most, recordings from 16 different video cameras or 16 recorded events can be simultaneously played on the program screen.

Launching Record Player

To launch Remote Player, click  on the Site Server program screen. You can also run this program from the Windows "Start" menu by selecting Start - Programs - huperVision v1.5 - Record Player.

By default, Record Player will allow any user to have access to the program. To restrict the program's access rights only to the local Administrator or to an authorized user account, you can enable access control via Site Server. For more information on this, see Chapter 2.

When access control is enabled, you will be prompted to logon to the Record Player. In the Log in dialog box, enter "Administrator" or the authorized user account name as the Login name and enter the Password. Then click OK.

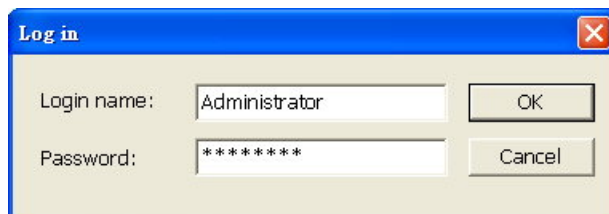

Program Interface: An Overview

Basically, these are the controls that you will need to use when you retrieve history records and play back previously recorded videos:

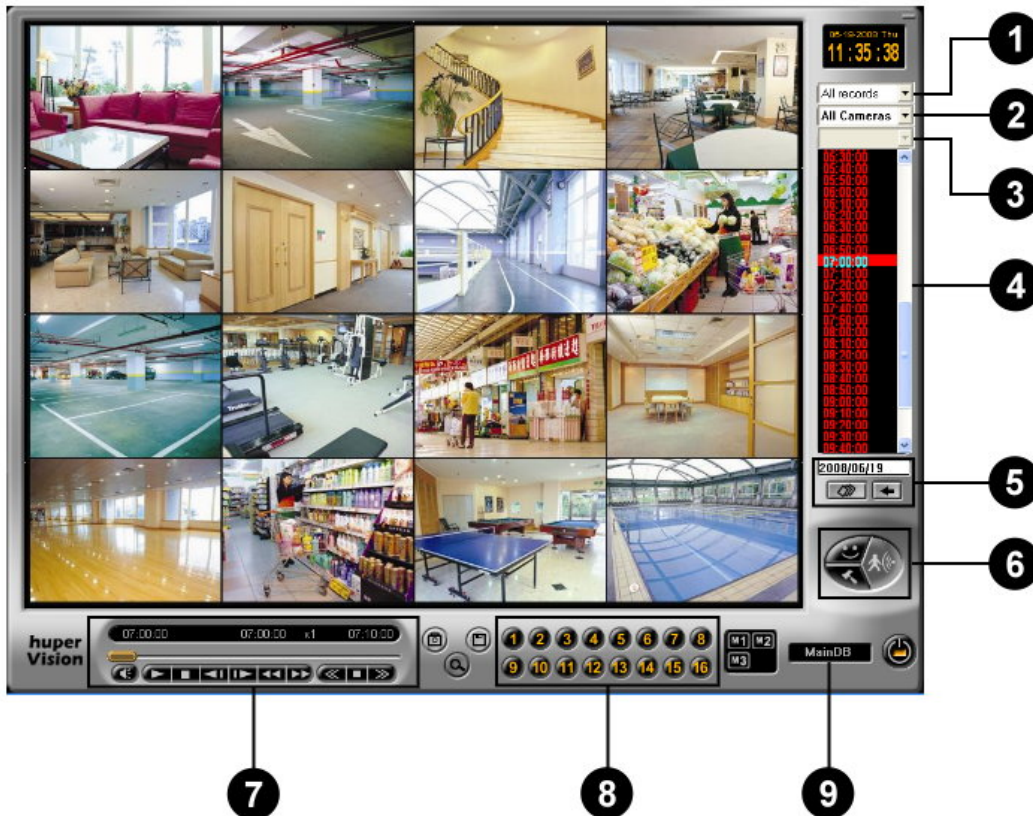

- 1** Record type From this drop-down list, choose whether to search for video recordings by time segments or by the type of events. Select "All records" to search by time segment.
- 2** Camera From this drop-down list, choose all or a single camera where to retrieve records from.
- 3** Line/Area name If you are searching for Virtual fence detection or Secure zone detection events, you can choose the Line name or Area name from this drop-down list.
- 4** History list Select a time segment or event from this list.

- 5** Date controls To access a specific day's history records, specify the date and retrieve its records by using these controls.
- 6** Other controls Click these buttons to access the Preferences dialog box, apply Smart Detection to video records, etc.
- 7** Navigation Panel Use the navigation controls for playback of video recordings.
- 8** Camera selection This is the Camera Selection Panel. Click the camera number to select a camera. The controls here will change when you switch to displaying history records by type of events.
- 9** Database This shows the name of the database that contains video records.

Types of databases

There are two types of databases that can be loaded into Record Player and from which history records can be retrieved:

Main database

This is the default database that is opened in Record Player, and it is the video database that the Site Server program uses to save recorded surveillance video. The record storage allocated in Site Server's Preferences dialog box: General tab comprises the entire Main database. (See "Assigning disk storage" in Chapter 2 for details on allocating record storage.)

Backed-up databases

These databases contain daily/manual backup copies of recorded surveillance video. Each day's digital recordings can be backed up in a separate database using huperVision's Backup Scheduler program. (Refer to Chapter 4 for more information on Backup Scheduler.)

Loading a backed-up database

To load a backed-up database:

1. Click , then on the pop-up menu, click Locate.
2. In the Locate dialog box, the paths of previously backed-up databases will be listed in the drop-down list. Select one of these databases, or if the desired database is not listed, click Browse to locate it.
3. After loading a backed-up database, you can select the "Main database" in the Locate dialog box to return to the Main database.

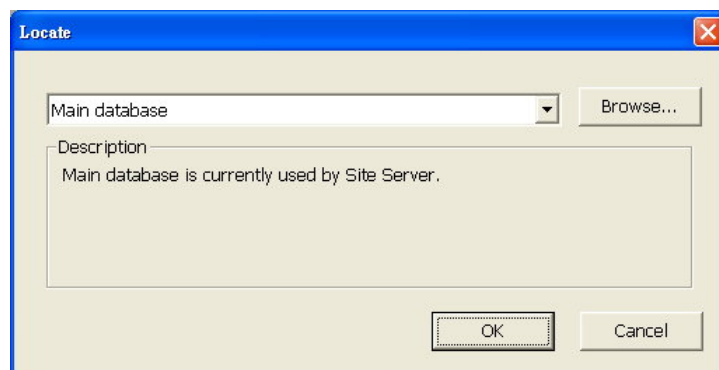

Viewing recorded video

To search for recorded surveillance videos and view them, first choose the date of recording, select the video camera, and retrieve the history records of the selected date and camera. Then, use the Navigation Panel to play back recorded videos.

Selecting the date of recording

There are two ways of selecting the recording date:

- Enter the date of recording in the text box beneath the history record list, and click  to retrieve the history records of the selected date.



Or,

- Click . A Calendar then opens, displaying the current month. The circled day on the calendar indicates that it is the current date. The boxed days indicate that there were recorded videos during those days.

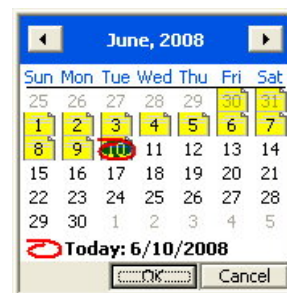

To select a date:

- Click the left/right arrow button to display the previous/next month on the calendar.
- Click a date on the calendar to select it.
- Click OK to close the Calendar.
- The history records of the selected date are automatically retrieved.

History records of the selected date are then displayed in the History list. To find and play back video recordings from the history list much faster, you can refine the search by limiting the search to time segments or to specific type of events.

Retrieving records from a specific camera

To retrieve records from a specific camera:

- Choose the camera number where you want to retrieve records from the "Camera" drop-down list.
- From the "Record type" drop-down list, choose the type of record you want to retrieve.

Viewing records by time segments

To view records by time segments:

1. Select "All Records" from the "Record type" drop- down list.
2. By default, the History list displays time segments in intervals of one hour.
To change the interval, click  then click Preferences in the pop-up menu. In the Preferences dialog box, specify the desired interval for displaying time segments.
3. Click a desired time segment in the History list.
4. Select All Cameras in the Camera drop-down list, then in the Camera Selection Panel, click the cameras whose video recordings you want to access for the selected time segment. As you select more cameras, the number of split screens increases. (See "Selecting video cameras" below for more details on Camera buttons and split screens.)

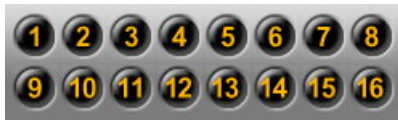

Note: To have different combinations of camera selections and store each set of combinations, use the Memory buttons. (See "Memory buttons" for details.)

5. When you click the Play button on the Navigation Panel, video recordings from the selected cameras will simultaneously be played on-screen. (See "Navigation Panel" for more details.)

Selecting video cameras

The Camera buttons in the Camera Selection Panel are only enabled when All Cameras is selected in the Camera drop-down list. The Camera buttons on the Camera Selection Panel are toggle buttons and allow multiple selection of video cameras. To view recorded videos from selected cameras, choose the video cameras by clicking the corresponding number buttons. To deselect video cameras, click on their corresponding number buttons again.

The number of selected cameras determines the split screen layout of the Record Player program screen, as depicted in the table below.

Number of selected cameras	Split screen layout
1 camera	Single view
2 to 4 cameras	4 split screens
5 to 9 cameras	9 split screens
10 to 16 cameras	16 split screens

Memory buttons

When you need to select different video cameras per time segment, it could be tedious to keep on selecting and deselecting the Camera buttons on the Camera Selection Panel. To save you the trouble of reselecting and deselecting cameras, Record Player provides three Memory buttons that can be used to store three different combinations of camera selections. These memory buttons are only enabled when All Cameras is selected in the Camera drop-down list.

To store a combination of camera selections to a Memory button:

1. Select the desired cameras (or deselect unwanted cameras) by clicking the Camera buttons on the Camera Selection Panel.
2. Click and hold your mouse over a Memory button for 2 seconds. The Memory button flashes slowly as it stores your camera selections. Release your mouse button when you see the Memory button flashes more quickly.
3. Repeat the above steps to store other combinations of camera selections to the other Memory buttons.

Next time you click on the Memory buttons, Camera buttons will automatically be selected according to the stored combinations.

Viewing records by events

To search for video recorded events, select one of these three options from the "Record type" drop-down list:

- All events

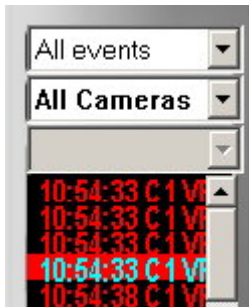

When selected, the program searches for all events that were recorded on a specified date and displays them in the History list.

The History list displays these all types of recorded events, which include: Motion, Sensor, Manual, Missing & left object, Flame, Virtual fence intrusion, and Secure zone intrusion. The list shows the time of recording, camera number, and the type of event.

The type of event is indicated as follows:

(Mo)	Motion event
(S"n")	Sensor event, where "n" represents the sensor number
(Ma)	Manually triggered event
(Fl)	Flame
(Mi)	Missing & left object event
(Vf)	Virtual fence intrusion
(Sz)	Secure zone intrusion

- Motion events

When selected, the program searches for all motion detected events that were recorded on a specified date and displays them in the History list. The History list shows the actual time of recording and the camera device that recorded the event.

- Sensor events

When selected, the program searches for all sensors detected events that were recorded on a specified date and displays them in the History list. The History list shows the actual time of video recording and the sensor device that detected the event.

- **Manual events**
When selected, the program searches for all manually triggered recordings of a specified date and displays them in the History list. The History list shows the actual time of video recording and the camera device from which surveillance video was recorded.
- **Flame events**
When selected, the program searches for recordings that have flames detected during a specified date and displays them in the History list. The History list shows the actual time of recording and the camera device that recorded the event.
- **Missing & left object detection events**
When selected, the program searches for all missing object and suspicious object events that were detected and recorded on a specified date and displays them in the History list. The History list shows the actual time of recording and the camera device that recorded the event.
- **Virtual fence detection events**
When selected, the program searches for video records that recorded people or objects passing through detection lines during a specified date and displays them in the History list. The History list shows the actual time of recording, the camera device that recorded the event, and the Line number.

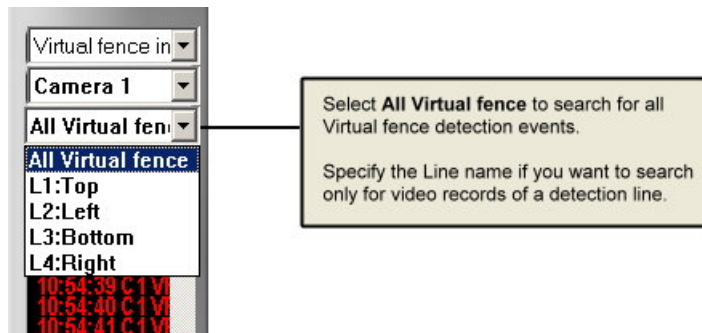

- **Secure zone detection events**
When selected, the program searches for video records that recorded people or objects entering forbidden zones during a specified date and displays them in the History list. You can search for all Secure zone detection events, or specify the Area name if you want to search only for video records that recorded intrusions on one specific area.

Viewing video recorded events

When you switch to displaying history records by event, Record Player provides the following button controls for setting the split screen layout and for navigating between records in the History list.



Split Screen Layout buttons

Set the number of split screens to use for event playback by clicking one of these buttons. Up to 16 split screens can be selected.



Record Navigation buttons

When playing back events in single view, click these buttons to move up or down one record in the History list.

Whereas when playing events in split screen view, the event that is currently selected in the History list will be played back in the first split screen, and the events that follow it in the History list will be played simultaneously in the other split screens.

Clicking the Record Navigation buttons will allow you to move up or down the History list by multiples of 4, 9 or 16 records, depending on the number of split screens selected for event playback.

Setting display and audio playback preferences

When viewing recorded videos, you can choose to display information on-screen, enable quick display and loop the recorded video. Play the audio associated with the recorded video by setting the appropriate options.

Click , then on the pop-up menu, click Preferences to open the Preferences dialog box and customize these settings.

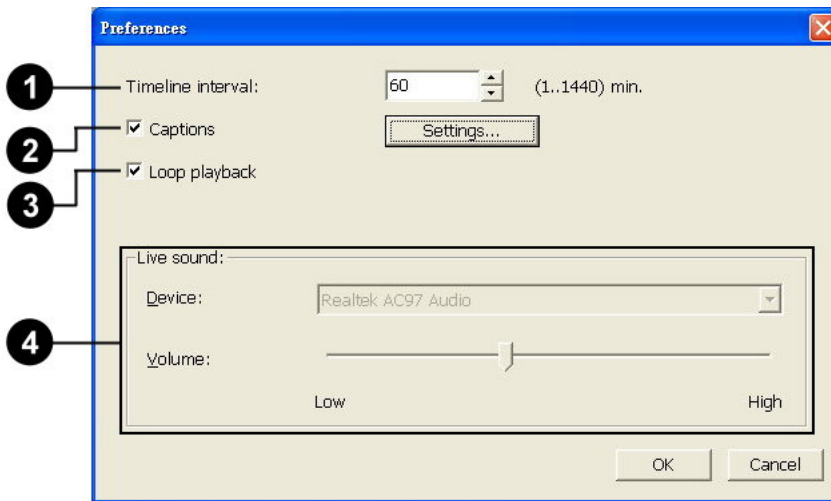

- 1** Timeline interval This setting determines the interval of time segments (in minutes) that are displayed in the History list.
 PS.: If you want to save AVI file which the time section is across a single timeline interval (eg: 9:30~10:20), you need to change the interval value to let the time section located within a single interval (eg: 180 min).
- 2** Captions Select this option to show information on the split screens. Click the Settings button to open the Captions dialog box and select which information to display on the split screens. When displaying records by time segments, select the information checkboxes in the upper group box in the Captions dialog box. Whereas when displaying records by event, select the information checkboxes in the lower group box. Click the Font button to choose a font size and style for the displayed information.

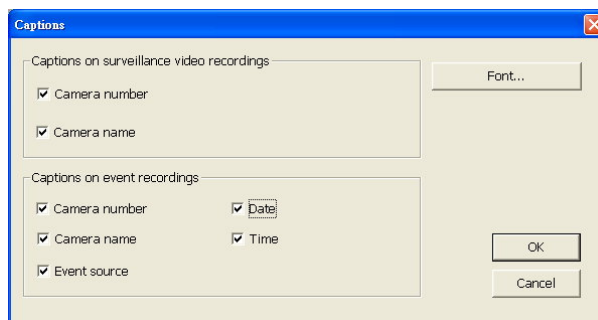

- 3** Loop playback Select this option to continuously replay the recorded videos.

- 4** Live sound Displays the audio device used by your computer to play back the audio of the recorded video. You can also adjust the playback device's volume here.

Navigation Panel

Use the Navigation Panel to control the playback of recorded video.

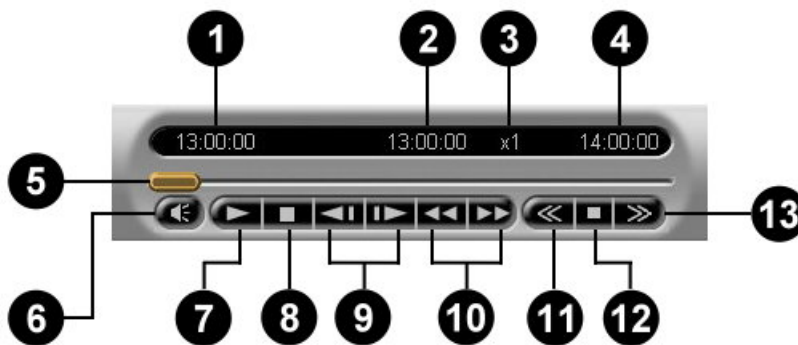

- 1** Start Timecode When playing records that were selected from the "All records" list, this shows the start time of the selected time segment.

When playing events, 00:00:00 will be shown as the "Start Timecode".

- 2** Current Timecode Shows the timecode of the current video scene.

- 3** Playback Speed Shows the current playback speed.

- 4** End Timecode When playing records that were selected from the "All records" list, this shows the end time of the selected time segment.

When playing events, the maximum time length between events will be shown as the "End Timecode".

- 5** Jog Bar Allows you to jump directly to any part of the recorded video. Drag the slider tab to the desired part of the recorded video.

- | | |
|-----------------------------------|--|
| 6 Mute | Toggles between playing/muting the audio associated with the recorded video. |
| 7 Play / Pause | Plays/Pauses the playback at the current frame. |
| 8 Stop | Terminates the playback and moves to the starting frame. |
| 9 Previous / Next Frame | Moves to the previous/next video frame |
| 10 Backward / Forward | Moves back/forward one or more video frames. |
| 11 Decrease Playback Speed | Slows down video playback. Click once to play the recorded video at half (1/2 x) the normal speed. Click again to play the video at a quarter (1/4 x) of the normal speed. The slowest speed is 1/8 x. |
| 12 Normal Playback Speed | Plays the recorded video at its original speed. |
| 13 Increase Playback Speed | Increases the playback speed of the video. Click once to double (2 x) the playback speed. Click again to quadruple (4 x) the playback speed. The maximum speed is 128 x. |

Zooming the video during playback

When playing recorded surveillance video in single view, you can zoom in or out of the video with ease. Click the  button repeatedly to cycle through different video frame sizes: "320 x 240", "640 x 480", and "Fit into Split Screen".

Detecting motion and suspicious objects on recorded video

When playing back recorded video from a selected camera, Motion Detection can be applied to the video. This allows you to instantly spot movements on video.

On the contrary, on a busy scene with lots of people and objects in motion such as in an airport or railway station, the Missing & Left Object Detection function can be applied. For instance, baggage that have been left on the scene for a long period of time will seem suspicious, and you can use this function to track them. You can also use this

function to detect if an object has been moved out of the scene (such as a wall painting that has been stolen).

Click  to open the Search Criteria Panel and choose whether to apply motion detection or missing & left object detection on a video recording. Follow the numbered sequence in the image below to specify how detection will be applied.



- 1** Record type From this drop-down list, choose whether to search for "All records", or to search for event recordings only such as Motion, Sensor, Manual, or Missing & left object detected events.
- 2** Camera list From this drop-down list, choose "All Cameras" if you want to see a list of video recordings from all the video cameras, or choose the Camera number of the desired video camera.

Note: Event Search is not available when "All Cameras" is selected.

- 3** Video recordings

By default, the video recordings of the current date are displayed in the list. Click a video recording in the list to select it.

To access older video recordings, click  to open the Calendar then choose the desired date.
- 4** Detection type

From the drop-down list, choose the type of detection to apply to the video recording. Select Motion detection or choose Missing & left object detection.
- 5** Open/Close
Mask-drawing Panel





Click  to open the Mask-drawing Panel. This panel contains button controls which allow you to mask out areas that will be excluded from detection.
- 6** Profile Selection Panel

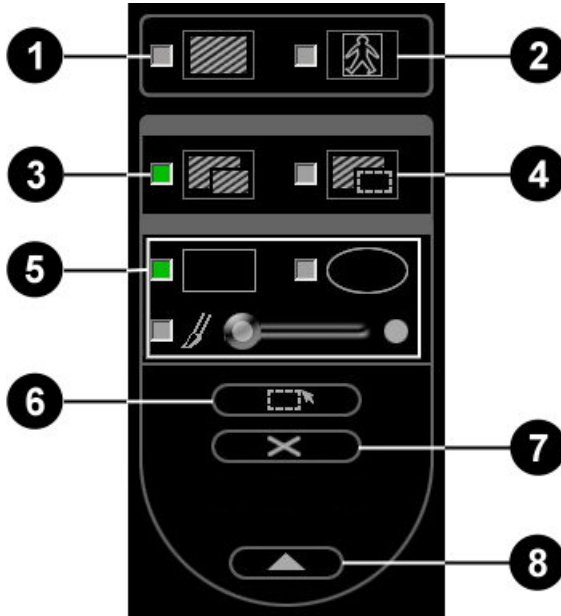

Use the controls in this panel to select, create, or modify a profile. See "Working with profiles" for more details.
- 7** Search controls

In a chosen video recording, you can limit the search for detected motion or static objects within a timecode range. Use this set of controls to control the search and how search results are displayed. See "Searching for detected motion or static objects in a video recording" for more details.

Masking out areas to exclude from detection



- 1** Show mask  Select this option to display a mask (i.e., a shield) on the areas that will be excluded from detection.
- 2** Show tracking block  Select this option to display a rectangular box on areas that have been detected with motion or with static objects.
- 3** Add mask  Select this option to add a mask. Use the drawing tools to draw the mask.
- 4** Subtract mask  To add back parts from a masked-out area and include them during detection, select this option. Use the drawing tools to erase the mask.
- 5** Drawing tools

 - Rectangular mask  Select this tool to draw a rectangular-shaped mask. Drag your mouse over an area on the video to draw the mask.
 - Elliptical mask  Select this tool to draw an elliptical -shaped mask. Drag your mouse over an area on the video to draw the mask.

Draw by Brush



Select this tool to draw a freeform-shaped mask. Drag the slider to the right to have larger-size brush strokes, or drag to the left to have smaller-size strokes. To draw the mask, drag your mouse over an area on the video.

6 Mask All



Click this button to mask out the whole video and then switch to the Subtract-mask mode automatically.

7 Clear Masks



Click this button to erase all the masks and then switch to the Add-mask mode automatically.

8 Close Mask-drawing Panel



Click this button to close the Mask-drawing Panel.

Working with profiles

A profile contains the motion detection or missing & left object detection settings. You can create your own profile or use the default profiles to apply to a video recording. The settings of your created profile can be modified; default profiles cannot be modified or deleted.

Profiles are listed in the Profile Selection Panel. To use the settings of a profile, simply click the desired profile.

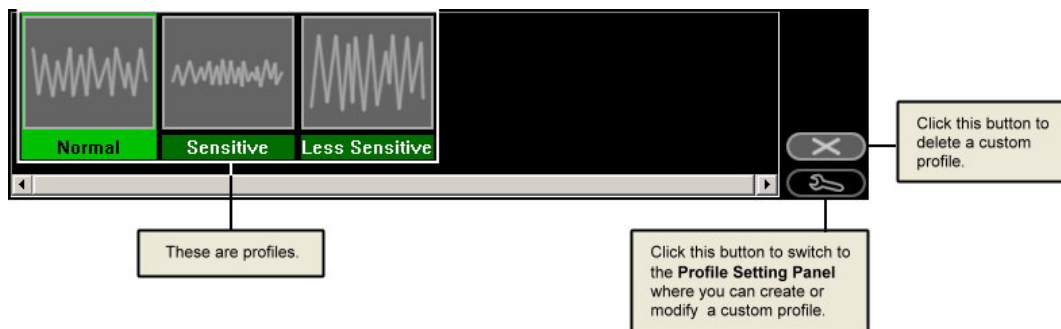

Motion detection settings

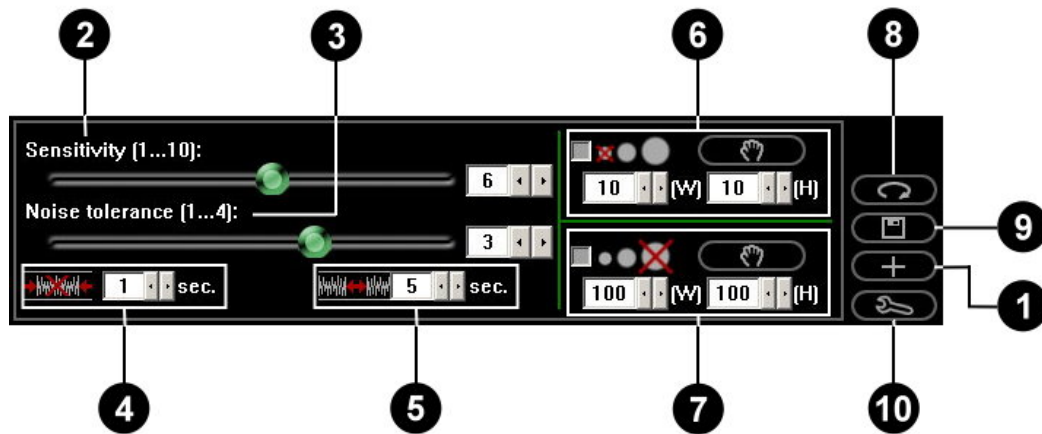

1 Create Profile

Click this button to add a new profile. When the Create New Profile dialog box opens, enter a profile name, then click OK.

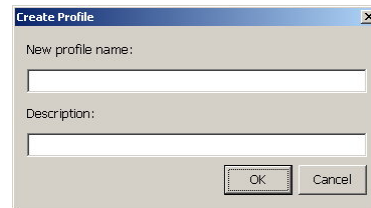

2 Sensitivity

This setting determines the sensitivity to motion. Drag the slider to the right to increase the sensitivity level, or drag to the left to decrease the sensitivity level. Low sensitivity means that minimal motion will be ignored, and that only dramatic changes in movement will be detected. However, this may result in loss of event. High sensitivity means that even the smallest movement will be detected, but it could be a false event. Careful testing and fine tuning of the sensitivity setting is recommended.

- 3** Noise tolerance

Moving elements on the video whose pixel sizes are smaller than the specified noise tolerance level will be treated as video signal noise and will be ignored. This can reduce the occurrence of falsely detected motion caused by video signal noise in low illuminated environments.
- 4** Smallest event duration

Specify the minimum time duration for each detected motion. If the duration of a detected motion is shorter than the defined duration, it will not be treated as motion.
- 5** Event interval

Specify the minimum interval between motion events.
- 6** Ignore small moving object

Select this option to filter out small objects (such as flashing stars in the sky or distant street lamps) whose dimensions are smaller than a specific size. To measure a small object to be used as the basis, click  then drag your mouse around that object. Its dimensions will then be entered in the width and height boxes.
- 7** Ignore large moving object

Select this option to filter out large moving objects (such as moving vehicles) whose dimensions are larger than a specific size. To measure a large object to be used as the basis, click  then drag your mouse around that object. Its dimensions will then be entered in the width and height boxes.
- 8** Reset to Default

Click this button to change the settings back to the original (or previous) settings.
- 9** Save Settings

Click this button to save the modified profile settings.
- 10** Close Profile Settings Panel

Click this button to return to the Profile Selection Panel.

Missing & left object detection settings

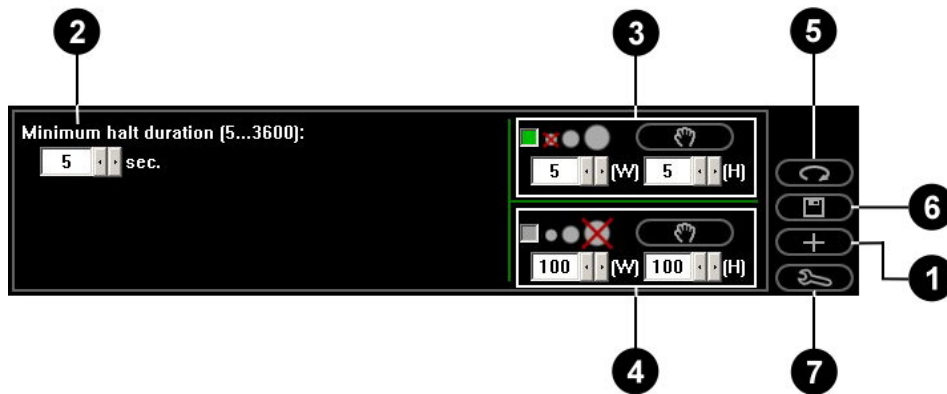

1 Create Profile

Click this button to add a new profile. When the Create New Profile dialog box opens, enter a profile name then click OK.

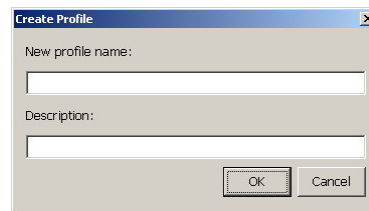

2 Minimum halt duration

Specify the minimum time duration when objects are expected to remain on its location. If an object remains on its location longer than the defined duration, it may be treated as a suspicious object. If an object is moved out of its location before the defined duration is over, it may be treated as a stolen object.

3 Ignore small object

Select this option to exclude small objects whose dimensions are smaller than a specific size. To measure a small object to be used as the basis, click  then drag your mouse around that object. Its dimensions will then be entered in the width and height boxes.

- | | | |
|----------|------------------------------|--|
| 4 | Ignore large object | Select this option to exclude large objects whose dimensions are larger than a specific size. To measure a large object to be used as the basis, click  then drag your mouse around that object. Its dimensions will then be entered in the width and height boxes. |
| 5 | Reset to Default | Click this button to change the settings back to the original (or previous) settings. |
| 6 | Save Settings | Click this button to save the modified profile settings. |
| 7 | Close Profile Settings Panel | Click this button to return to the Profile Selection Panel. |

Searching for detected motion or static objects in a video recording

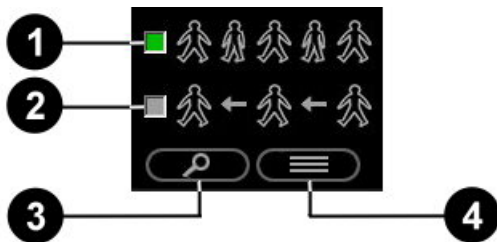

- | | | |
|----------|--------------|--|
| 1 | Full search | Select this option to apply detection on each video frame in a video recording. |
| 2 | Quick search | Select this option to advance forward through the video at intervals of 500 ms and apply detection only to the video frames that are at these intervals. |

3 Search

Click this button to open the Search dialog box where you can limit the search within a range of timecodes. To limit the search, specify the desired range of timecodes for searching detected motion or static objects. Otherwise, click All Record to search through the entire video recording.

After you have entered the start and end timecodes, click the Search button in the dialog to begin the search. The Search Result Panel will then be displayed, listing the video sequences that are found to have motion or static objects.

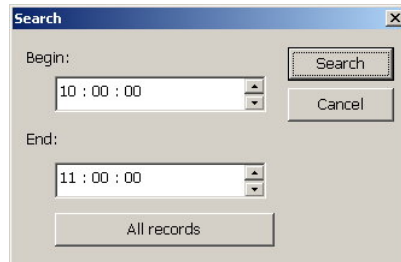

4 View Search Results

Click this button to switch to the Search Results Panel.

Note: The timeline interval of records displayed in the Record List is an hour by default. If you want to search through records in higher intervals, for instance, in two-hour intervals, first open the Preferences dialog box then enter 120 minutes in the "Timeline interval" edit box.

Search Results Panel



Display by List



Display by Thumbnail

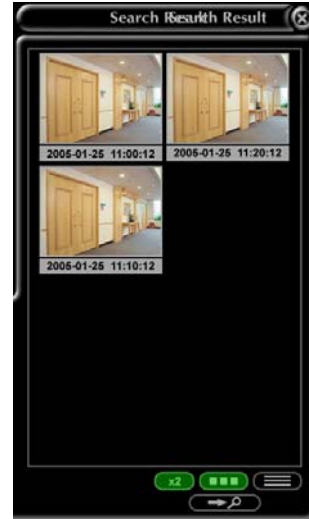

Display two-column
Thumbnails



Click this button to display search results as a list of timecodes.



Click this button to display search results as a list of visual thumbnails.



Click this button to expand the Search Results Panel and display more thumbnails by listing them in two columns.



Click this button to return to the Search Criteria Panel.

Saving video

The whole or part of a recorded surveillance video can be saved as a video file. Click  to open the following dialog box and specify the desired part of the video to save.

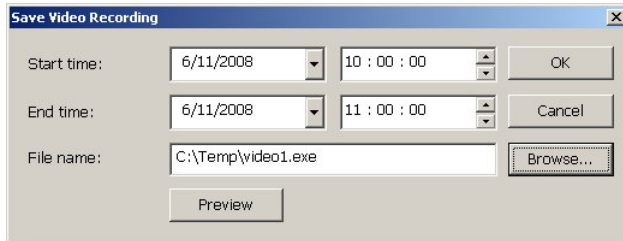

By default, the "Start time" and "End time" values are set to the actual start and end times of recording. To choose a portion from the recorded video, change the "Start time" and "End time" settings to the desired start and end timecodes.

To check whether you have selected the appropriate part of the video, click the Preview button. After previewing, click Browse to open the Save As dialog box where you can choose to save the video in .AVI or .EXE format. After selecting the video file format, enter the file name and folder path where you want to save the video file then click Save. You will then be returned to the Save Video Recording dialog box. Click OK to confirm saving the video file.

If you chose to save the video as a self-executable (.EXE) file, you will be prompted to enter a password for the file.

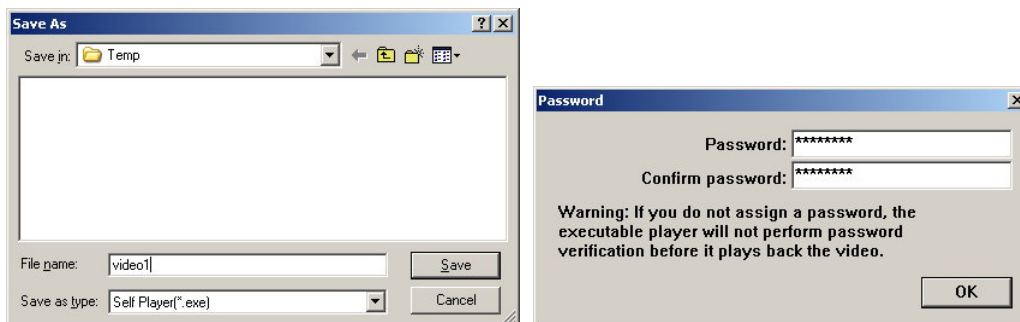

Self-executable Player

Saving the video as a self-executable (.EXE) file gives an added protection to the video content. A digital signature and a password will be embedded in the file. The user who receives the video file will be required to enter a password first before the video can be played. This ensures that the video is viewed only by the people you have authorized. Also, saving it in this format frees the user of having to use another video player to view the video. If password verification is not required, the video will automatically play when accessed.

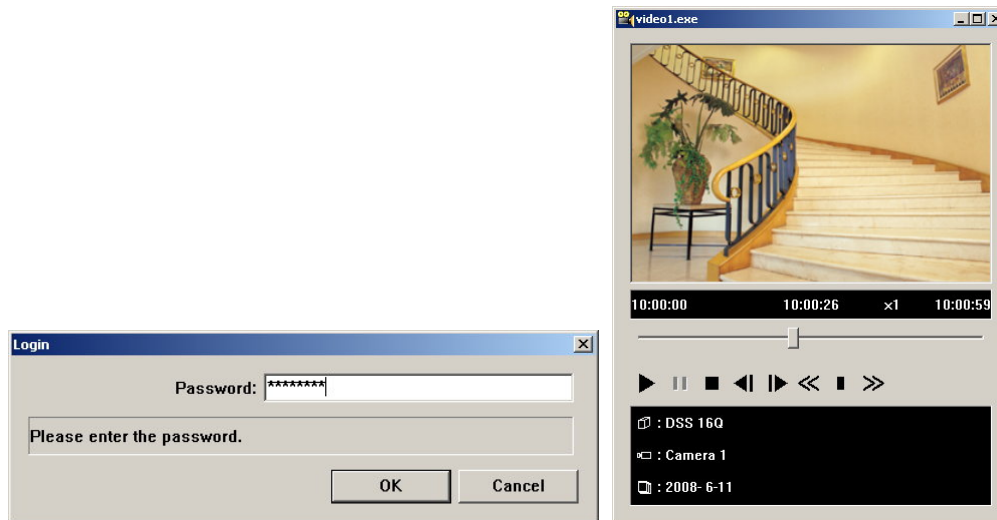

Capturing image snapshots

If a video recording clearly shows suspicious activities or an intruder in the monitored site, you can notify police authorities and provide them with actual image snapshots. To take a snapshot, first play back the recorded video, and then click the  button. The Snapshot dialog box then opens, allowing you to enhance the captured image by adjusting brightness, contrast, sharpness, hue, and saturation. You can also choose to add captions on the captured image, enlarge the image by zooming, as well as print and save the captured image.

For added protection to the image, you can select the Apply watermark to saved image checkbox to embed a digital watermark.

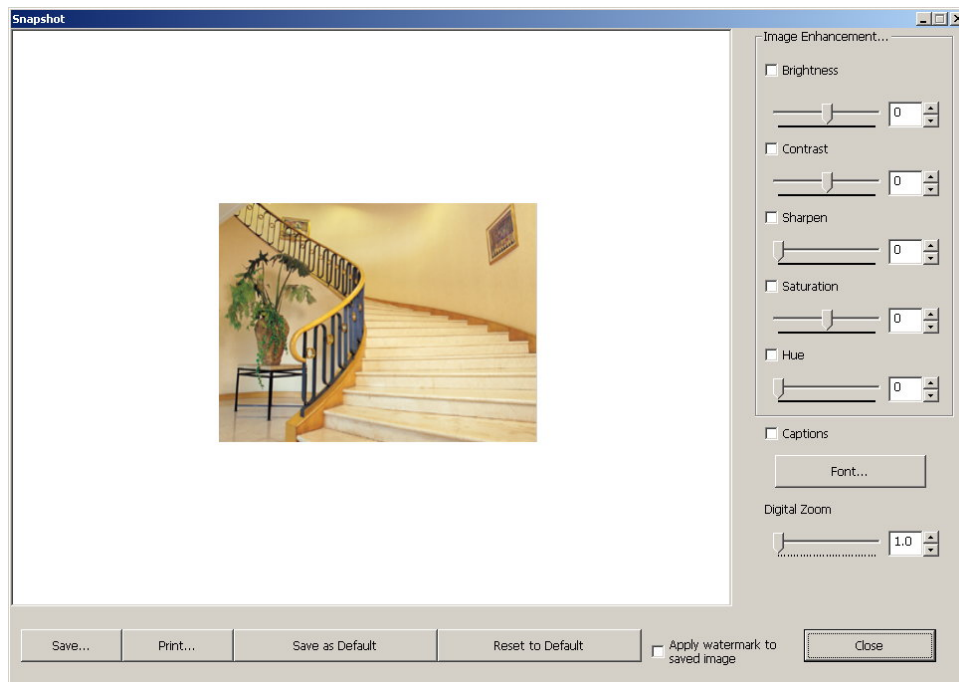

Notes: When you click Print and you don't have a printer installed, it will prompt a message asking you if you want to install a printer first.

Click Save as Default to save the modified settings in this dialog box.

To change back to the original default settings, click Reset to Default.

Chapter 4

Backup Scheduler and Other Utilities

Use the Backup Scheduler program to make regular backups of the recorded surveillance videos. This program allows both manual and scheduled backups. Manual backup allows you to specify the date and time range of video recordings to back up. Whereas when scheduled backup is enabled, the program automatically performs daily backups of surveillance videos that were recorded during a specific time frame in a day.

Launching Backup Scheduler

To launch Backup Scheduler, click Start - Programs - huperVision v1.5 - Backup Scheduler.

If access control is enabled in Site Server's Preferences dialog box - Users tab, users who run the Backup Scheduler program will be prompted to provide login information. To be able to use the Backup Scheduler program, the login name and password entered must belong to an existing user account that has been assigned with the "Administrator" privilege level or a privilege level that has "Backup" authority. Only users with these privilege levels are allowed to configure backup settings.

Program interface: an overview

When you launch Backup Scheduler, the main program screen opens and automatically displays the Data Size dialog box where you can perform a manual backup. In this dialog box, you can set a range of video recordings to backup by specifying your desired start and end dates. For more information on how to configure settings for a manual backup, see "Performing manual backups".

The main program screen shows a list of past backups. From the program screen, you can manage your backups, initiate a manual backup or set up automatic backups. The following describes the controls and settings on the main program screen.

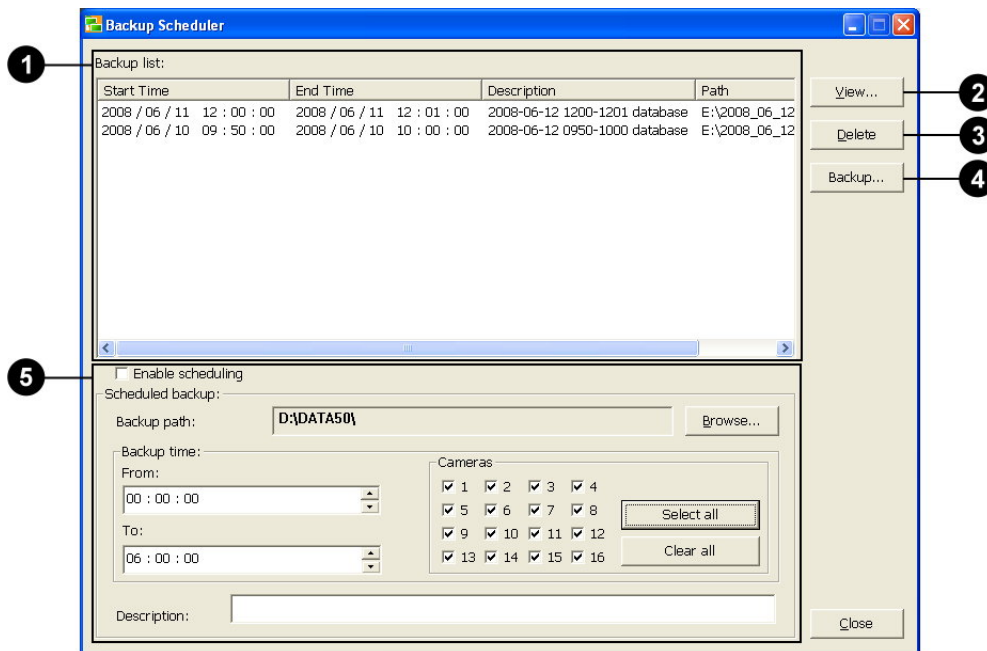

- 1 Backup list

Keeps a record of past backups. Each backup entry in the list corresponds to a backup database folder. Each backup entry shows the date and time range of the surveillance videos that were backed up, a textual description, and the backup database folder path.

- 2** View
Plays back the surveillance videos that are stored in a backup database.
To view the backed up surveillance videos, select the appropriate entry from the Backup list and then click View. Record Player automatically opens where you can play back the videos.
- 3** Delete
Deletes one or more selected entries in the Backup list. Deleting entries will also physically delete their corresponding backup database files.
To select multiple entries, hold down the [Ctrl] key and click each entry you want to delete. Then, click Delete to delete them.
- 4** Backup
Allows you to manually initiate a backup when there are recorded surveillance videos in Site Server's Main database. (See "Performing manual backups".)
- 5** Scheduled backup
Enables the Backup Scheduler program to perform automatic backups on a daily basis. (See "Setting up automatic backups")

Performing manual backups

Manual backup allows you to selectively back up surveillance videos that were recorded by Site Server within a date and time range. To perform a manual backup, click the Backup button to open the following dialog box and configure backup settings:

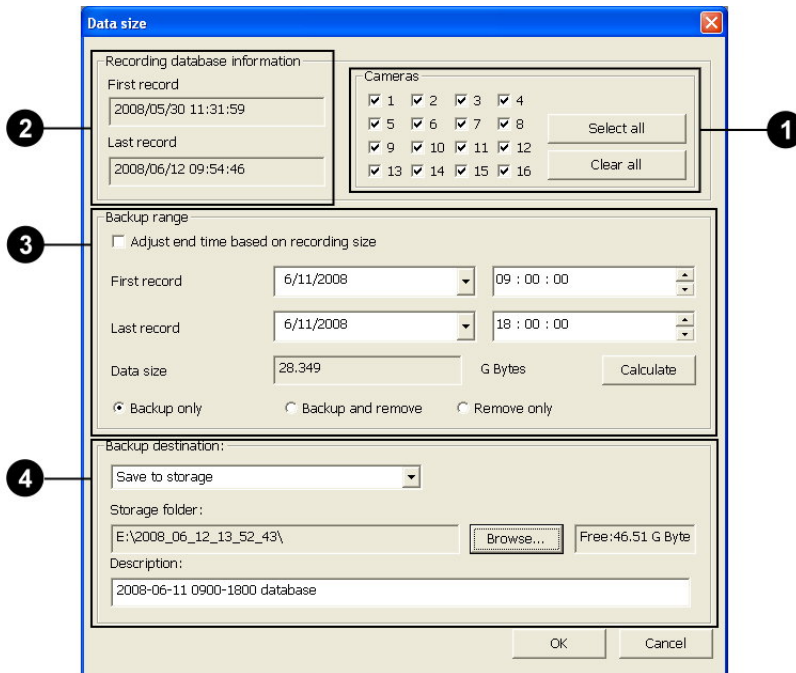

- 1** Cameras

You can select which particular video cameras you want to back up video recordings from. To select individual cameras, simply click the checkboxes of the desired camera numbers. You can also click Select All to quickly select all the cameras. If you want to start all over in choosing cameras, you can click the Clear All button first to clear all the checkboxes, and then make your selections again.
- 2** Record database information

This displays information about the video recordings that are currently stored in Site Server's Main database. The information here shows the first surveillance video's date/time of recording and the last video's date/time of recording.
- 3** Backup range

The options here determine which video recordings to back up and whether to remove them from the Main database after the backup process is complete.

- Adjust end time based on recording size When selected, you can specify the data file size of the video recording you want to back up or delete. After you enter the file size in the "Data size" text box and the starting date/time of the video recording in the "First record" text box, the "Last record" text box will be filled in with the ending date/time based on your specified file size after clicking Calculate.
- First / Last record Allows you to specify the date and time range of video recordings to back up.
If you selected the "Adjust end time based on recording size" option, there is no need to specify the ending date/time range in the "Last record" text box. It will automatically be determined.
- Backup only When selected, the program backs up the video recordings that fall within the specified date and time range, and retains them in the Main database after the backup process is complete.
- Backup and remove When selected, the program deletes the video recordings that fall within the specified date and time range after backing them up.
- Remove only When selected, the program deletes video recordings without performing a back up first.
- Calculate Click this button to automatically determine the data file size of the video recording to be backed up (or removed) based on the date and time range specified in the "First record" and "Last record" text boxes.
This button works only when the "Adjust end time based on recording size" option is not selected.
- 4** Backup destination Choose the location where to save the backup and enter a textual description that identifies the contents of the backup database.
There are two options for the backup destination:

Save to storage

Let you save the backup to a specified folder in the hard drive. Click Browse to choose a folder.

The available space of the selected folder must at least be the same size as the recordings to be backed up. After you selected a folder, the free space that is available on that folder will be shown to the right of the Browse button. If the chosen storage space does not have enough free space, a warning message will be displayed and the manual backup will not be performed.

Burn to CD/DVD

Let you save the backup onto a CD or DVD.

If the computer that is running Backup Scheduler has been installed with the Nero burning software (version 6.0 or higher), Backup Scheduler will use it to burn the CD/DVD. Otherwise, it will use Windows XP's built-in burning function. Windows XP's built-in burning function only supports CD burning and does not provided DVD burning at this moment. For more information about CD/DVD backup, see "Burning a CD or DVD".

Setting up automatic backups

Backups can be automatically performed by Backup Scheduler according to your preset schedule. At most, you can set up the program to back up surveillance videos that were recorded by Site Server for the last 24 hours. Configure these settings to set up a schedule for automatic backups:

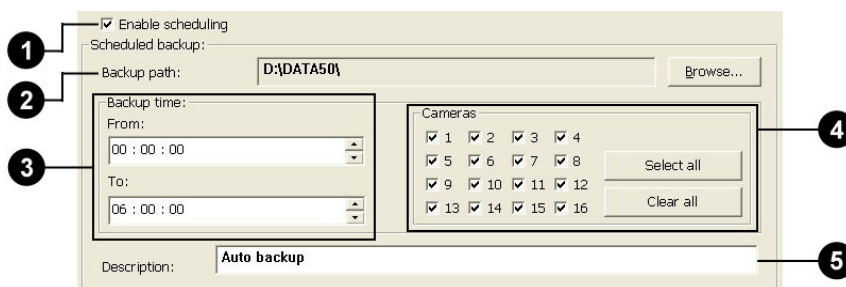

- 1** Enable scheduling Select this option to activate automatic backups. Choose your Backup path first before you select this checkbox.
- 2** Backup path Specify the destination folder for saving the daily backups. Each day's surveillance videos recorded by Site Server will be saved as an individual backup database.
- 3** Backup time Specify the time period to back up the previous day's video recordings.
- 4** Cameras You can select which particular video cameras you want to back up video recordings from. Select individual cameras by clicking their checkboxes, or click Select All to select all cameras. If you want to start all over in choosing cameras, you can click the Clear All button first to clear all the checkboxes, and then make your selections again.
- 5** Description Enter a textual description that identifies the contents of the backup database files.

Note: Backup processes are given lesser priority than digital video recording when both operations are performed simultaneously. When backup storage is not enough or an entire backup process cannot be completed within the specified period, a warning message will be displayed.

Burning a CD or DVD

When you choose the Burn to CD/DVD option, huperVision will detect if Nero v6.0 (or later version) is available on the computer. If it is available, Nero will be activated to burn a CD/ DVD. If not, Windows XP's built-in burning function will be activated instead.

The screenshot shows a dialog box titled "Backup destination:" with the following fields and buttons:

- Backup destination:** A dropdown menu set to "Burn to CD/DVD", a text box containing "F: [\Device\Cdf]", and a button labeled "Free:702.00MB".
- Temporary folder:** A text box containing "E:\2008_06_12_13_58_56\", a "Browse..." button, and a button labeled "Free:46.51 G Byte".
- Description:** A text box containing "2008-06-12 0800-0805 database".

Through Windows XP's built-in burning function

You need to select a CD-RW or DVD-RW drive and specify a Temporary folder in which to store data that will be burned to CD-R. The available space of the temporary folder must be at least twice the space of the CD-R. To check if the available space is enough, refer to the disc space of the CD-R and the available space of the temporary folder that are shown on the dialog box.

If the available space of the temporary folder is less than twice the size of the CD-R, Backup Scheduler will display a warning message and the backup task will not be performed.

Through Nero's disc burning function

You need to select a CD-RW/DVD-RW drive to use for burning. When burning will be performed through Nero's disc burning function, the Temporary folder field and its Browse button are disabled. You must refer to Nero's documentation to find out how much storage space will be sufficient for the Nero CD burning utility to work properly.

How to burn the CD/DVD

After you have selected the burner to use and selected a temporary folder, click OK. The Data Size dialog box then closes and the Burn to CD/DVD dialog box will be displayed.

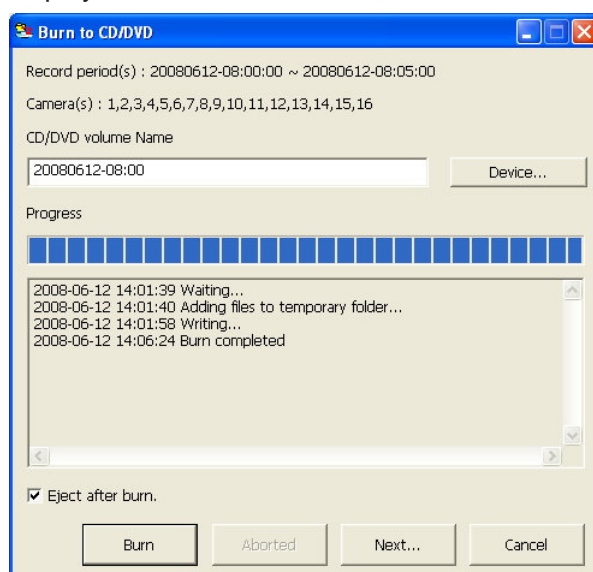

Enter the CD or DVD volume name. By default, the disc volume is named using the date and the start recording time (in hours and minutes) of the first video record.

To check the information about the burner and the path location of the temporary folder before you start burning, click the Device button.

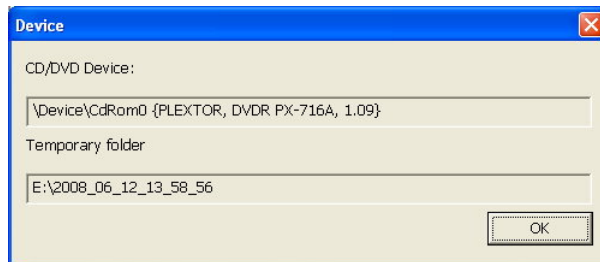

If you want the disc to be automatically ejected from the burner after disc burning has finished, select the Eject after burn checkbox. When you are ready to start burning the disc, click Burn. You can click the Abort button to cancel the burning process if this button is enabled.

After burning is completed, you can click the Burn button again if you want to burn another CD with the same set of records.

Click Next to prepare the next set of records to burn. You need to click the Burn button to start burning.

Watermark Inspector

Watermarking is a digital content protection technique that helps to identify tampered content. A watermark, which is an invisible mark, is embedded in images.

Any modification or tampering to image content can be identified by the Watermark Inspector program that is included with huperVision. If you applied watermark to the snapshots that you saved in Record Player, you can use Watermark Inspector for watermark verification.

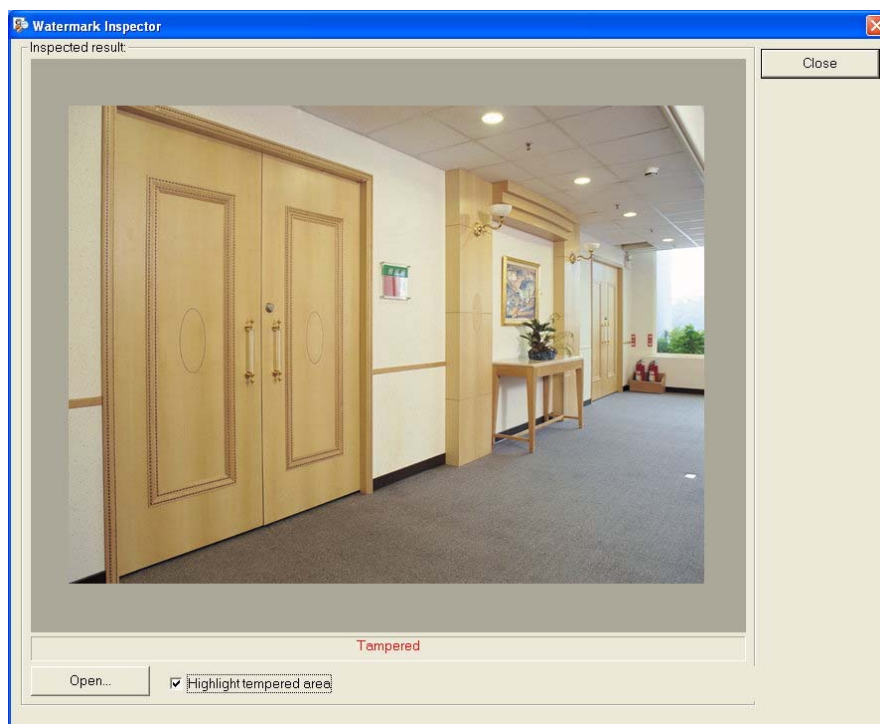

Follow the steps below to inspect an image using Watermark Inspector:

1. To launch the inspector program, click Start - Programs - huperVision v1.5 - Utilities - Watermark Inspector.
2. Click Open and select an image file to open.
3. The program then inspects the watermark of the image picture and shows one of the following status messages:
No watermark or destroyed watermark.
This message appears in red, and indicates that the image does not contain an embedded watermark.
Tampered.

This message appears in red, and indicates that the image content has been modified or tampered.

Image content is proved.

This message appears in blue, and indicates that the image content has not been modified or tampered.

4. If an image has been tampered and you want to find out which part of the image was tampered, you can select the Highlight tampered area check box. The tampered area will be highlighted in green.

Note that the checkbox is disabled when the image file you opened is a JPEG file. Only BMP images can be highlighted.

The examples below illustrate an image before and after it has been tampered.



Original image



Tampered image

(The two leftmost characters on the license plate)

Note: The size of the preview image area is 720x576 (PAL/D1). Images will be displayed in their original size.



Chapter 5

huperRemote

huperRemote provides up to 16 split screens on the user interface for you to simultaneously monitor remote cameras from multiple DVR sites. Each DVR site will have a DVR server computer that is connected to surveillance cameras and other security devices. You need to first specify the URL addresses and the login details of the DVR servers that you would like to connect to.

Connecting to Remote DVR Sites

To add and connect to a remote DVR site:

1. Click  to open the Connect dialog box
2. Enter the DVR site's URL address in the Site Server text box.
3. Clear the Guest login checkbox, then type in the valid User name and Password for connecting to the DVR site.
4. Select Add to connection list to add the DVR site to huperRemote's Camera List Panel, then click OK. huperRemote will then connect to the specified DVR site and display the remote cameras.
5. The DVR site will be added to the Camera List Panel. Click  to open this panel. See the names of different cameras in the DVR site, click on the "+" sign.
6. By default, the site is named with the site name that has been specified in the remote DVR site. To rename it, click on the text and type in the desired name.
7. huperRemote allows you to connect to multiple DVR sites at the same time. Repeat steps 1 to 6 to add more DVR sites.

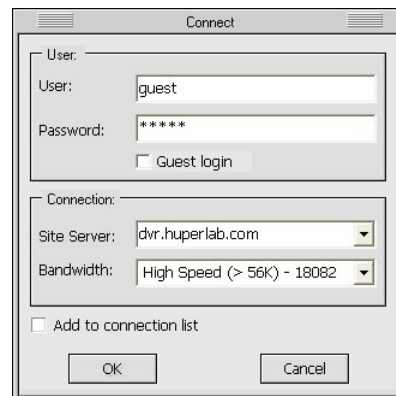

Note: If you want to change the information of a DVR site, select then right-click the DVR site name in the Camera List Panel. The Site Information dialog box will then open where you can make modifications.

Another way of adding DVR sites is to click  in the Camera List Panel. The Add Site/Group dialog box will then be displayed where you can add a new DVR site. This dialog box also allows you to create a group name for grouping existing DVR sites.

To connect and disconnect an existing DVR site:

To connect to a DVR site, double-click the site name in the Camera List Panel. Double-click the site name again to disconnect from the DVR site.

To disconnect all connected DVR sites:

Click . This closes all connections.

Monitoring Remote Cameras

When huperRemote has successfully established connection with the DVR site(s) that you added to the Camera List Panel, you will be able to see real-time video from the remote cameras on the site(s).

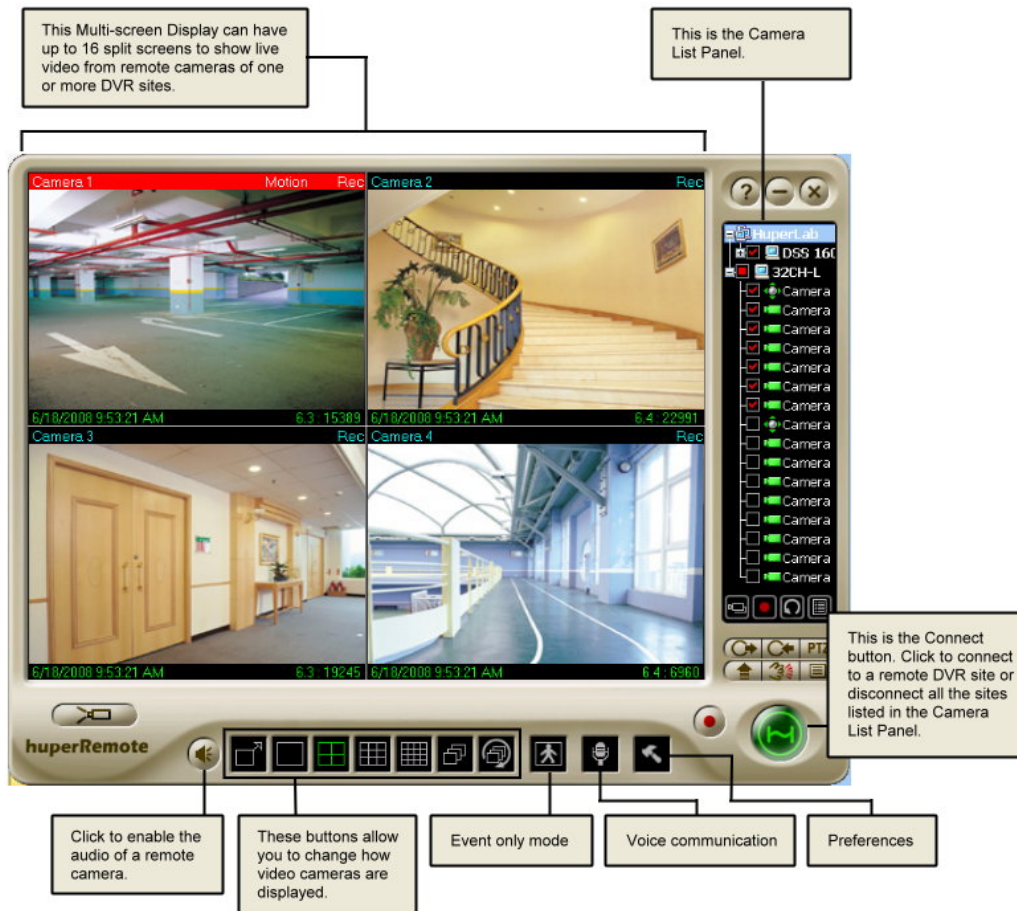

Split Screens

Split screens show live video from the video cameras that are installed in the monitored site or sites. On the split screens, the video camera number, current date and time, etc. can be displayed. If video recording for a certain camera is enabled on the DVR server, a "REC" indicator will appear at the upper right corner of the corresponding screen. When you have initiated video recording locally on your computer, you will see a red blinking indicator on the split-screen window.

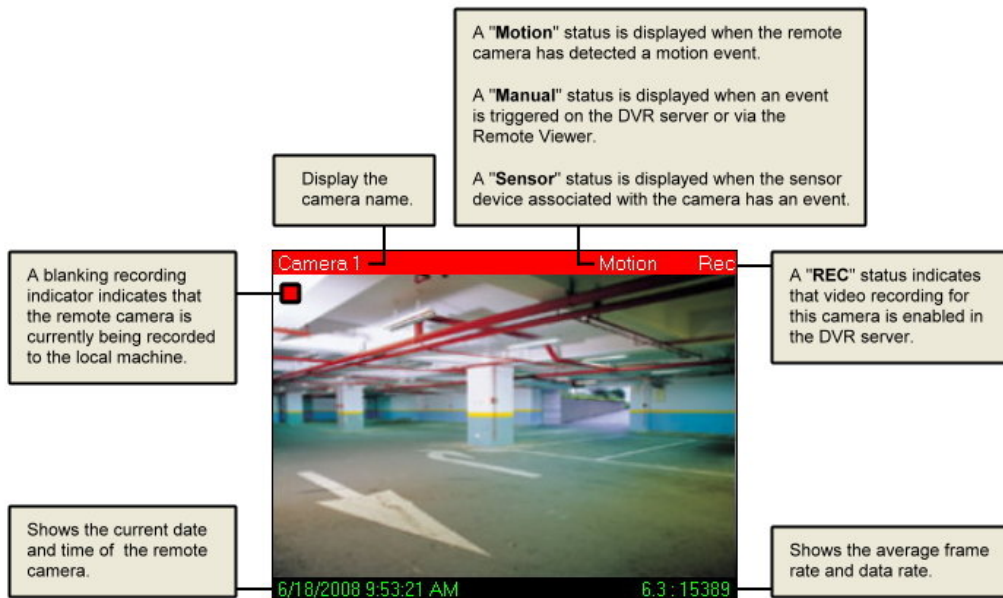

Note: Information displayed on split screens can be enabled or disabled in the Preferences dialog box: Caption tab.

Changing Split Screen Position

Drag a split screen and drop it to another split screen to exchange their positions.

Maximizing Split Screen Size

If there are 4, 9, or 16 split screens displayed, double-click a split screen to enlarge its size and temporarily cover its three neighboring screens. If continue to double-click, the split screen will be enlarged to the full window size.

Right-click on the split screen to restore it back to the previous size. When you continue to right-click on the split screen, it will return to its original size.

Split Screen Controls

Use these buttons to change how split screens are displayed on the program screen.



Toggles between Full-screen and Normal display modes.



Displays a split screen in full window size.



Splits the Multi-screen Display into 4 split screens.



Splits the Multi-screen Display into 9 split screens.



Splits the Multi-screen Display into 16 split screens.





If there are more remote cameras from other DVR sites that cannot be fit within the program screen, click this button to switch the display to the next group of cameras.



If there are more remote cameras from other DVR sites that cannot be fit within the program screen, click this button to loop the display of the cameras. After an elapsed time, the window screen will automatically switch to the next group of cameras or sites.

Displaying Cameras with Detected Events Only

Click  to display only the remote cameras that have been detected with events. The split-screen display of the other cameras will temporarily be turned off. In this mode, only detected events will be recorded if video recording is enabled.

To switch back and display all cameras, click  again.

Note: In the Preferences dialog box: Alarm tab, you can set up huperRemote to sound an alarm in your computer when there are detected events. (See "Configuring huperRemote" for details).

Enabling Audio from Remote Cameras

In case you see abnormal activities while monitoring a remote camera, you can enable the audio from the camera and listen to it through your computer speakers.

To do so, first click the split screen that displays the remote camera, then click . Click this button again to turn off the audio.

Voice Communication with a DVR Server

If the DVR server on the DVR site is enabled to accept two-way communication requests from remote client computers that are running huperRemote, you will be able to initiate voice communication with the person who is operating the DVR server.

Simply click  to initiate voice communication.

Note: You can specify which sound card to use for audio input and make adjustments to the sound volume in the Preferences dialog box: Voice Communication tab.

Remote Camera Controls

Use these buttons to have access to the different DVR sites and their respective remote cameras, and to control how video from these cameras are displayed on the huperRemote program window.



Click to change to the Output I/O Control Panel.



Click to change to the Input I/O Control Panel.



Click to change to the PTZ Camera Control Panel.



Increases the display frame rate of a selected camera. If your network connection bandwidth is limited, it may be helpful to increase the frame rate of the selected camera.



Triggers a manual event to a remote camera.



Expands the Camera List Panel. More button controls in the Camera List Panel will then be displayed. Click again to retract and change the panel back to its original size.

Triggering Manual Events to Remote Cameras

If you see abnormal activities on one of the remote cameras, you can manually trigger an event to that camera. To do so, first click the split screen that displays the remote camera. Then click  to trigger a manual event to the camera. This allows the abnormal activities to be logged and/or digitally recorded.

Note: The "Manual trigger" option of the remote camera must be enabled first at the DVR server.

Recording Surveillance Video

After huperRemote has connected to the DVR sites that you specified, the remote cameras on each site are, by default, all selected for monitoring only. You can record video from all cameras, or choose certain cameras to record video from.

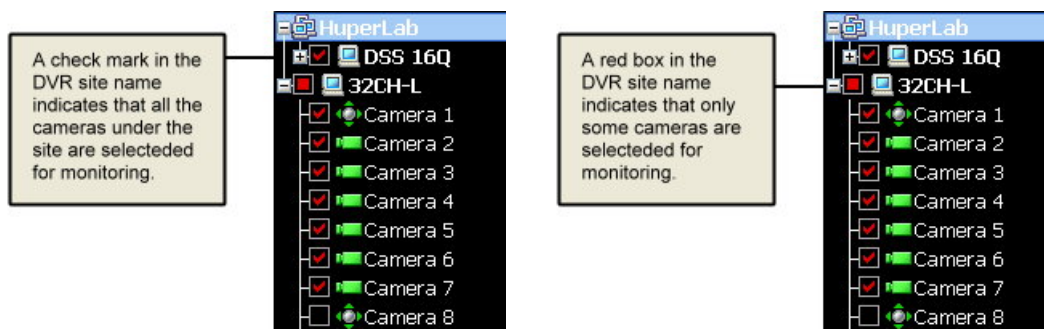

To record video from all remote cameras:

Click . Surveillance video from all remote cameras of the connected DVR sites will be recorded to your local hard drive. Click this button again to stop the recording.



To record video from selected cameras only:

1. Click a camera on the split screen to select it.
2. In the Camera List Panel, click  to start the recording. Click this button again to stop the recording.

Note: In the Preferences dialog box: Storage tab, you can delete old video recordings, and also specify when you want hard disk space to be recycled to free up disk space for saving new recordings. (See "Configuring huperRemote" for details).

The Camera List Panel

The Camera List Panel lists the DVR sites and customized camera groups that you can connect to. At the bottom of the panel are button controls for adding DVR sites or camera groups, connecting/disconnecting selected cameras, video recording, and more.

To expand the Camera List Panel, click . To retract and change it back to the normal panel size, click  again.



Expanded Camera List Panel

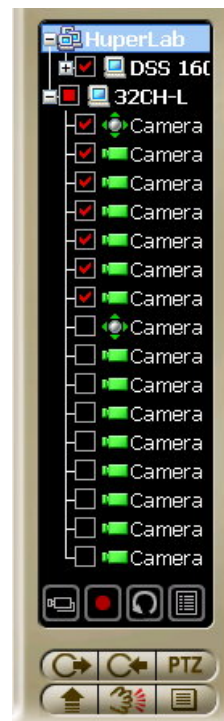

Normal-size Camera List Panel

Panel Controls

At the bottom of the Camera List Panel are two sets of button controls:



Allows you to connect to the selected remote cameras (that is, the cameras with check marks in the Camera List Panel).



Starts recording surveillance video from the selected cameras of a DVR site onto your local hard drive. Click again to stop recording.



Click to refresh the camera list of a selected DVR site.



Opens the Scheduler where you can create schedules for recording surveillance video. (See “Using the Scheduler” for details).



Click to add a new DVR site or group to the list.



Click to remove a DVR site or group.



Click to clear the entire Camera List Panel.

Panel Indicators



Description name of DVR site



Group



CCTV camera



PTZ camera



Indicates that the remote camera is selected. A check mark that appears on a DVR site name indicates that all cameras under it are selected.



Indicates that only some cameras in a DVR site are selected.



Grouping DVR Sites or Remote Cameras

You can create a group name to combine certain DVR sites into the same group.

If you only need to monitor certain cameras from each site, you can also create a group name to combine these cameras under the same group. This allows huperRemote to connect only to the required cameras instead of all the cameras on each site.

To create a group:

1. Click **+** to open the Add Site/Group dialog box.
2. Enter a group name in the Description text box, then click OK.

The new group name will be added to the first entry in the Camera List Panel.

3. You can add a whole DVR site or only selected cameras into the group:
 - To add a whole DVR site, first make sure that there is a check mark in its check box (which means that all cameras under this site are selected). If there is no check mark, click the check box. Then, drag and drop the DVR site into the group.
 - To add only certain cameras of a site to the group, first select the desired cameras. The check box on the DVR site will then be marked with a red box. Now drag and drop the DVR site into the group.
 - If you want to add only a single camera from a site into the group, select that camera then drag and drop it into the group.
4. Repeat step 3 to add more DVR sites or cameras into the group.



Group of DVR sites



Group of cameras from multiple sites

The PTZ Camera Control Panel

If there are PTZ cameras in any of the DVR sites, you can use the PTZ Camera Control Panel to zoom in or out and pan around the monitored areas. Click  to open the PTZ Camera Control Panel.

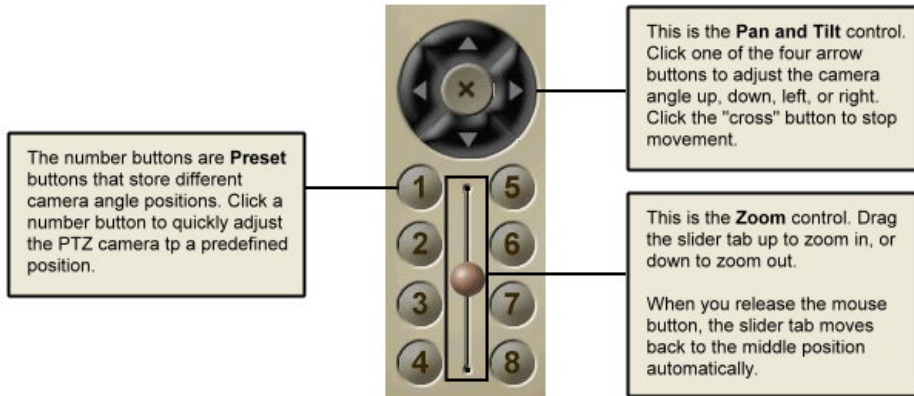

The Input I/O Control Panel

If there are input I/O devices connected to the DVR sites, you can use the Input I/O Control Panel to check the status of input devices. Click  to open the Input I/O Control Panel.

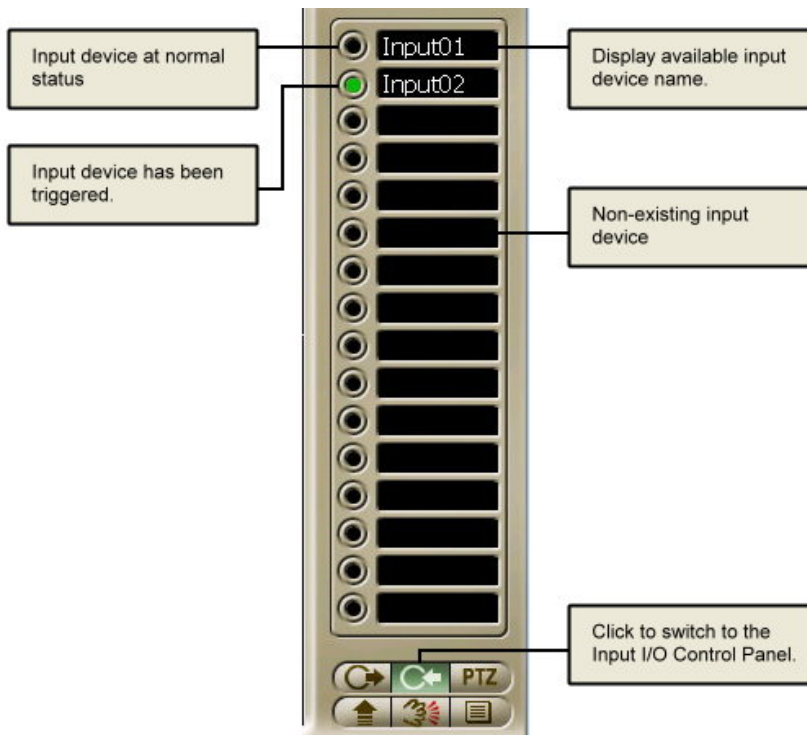

The Output I/O Control Panel

If there are output I/O devices connected to the DVR sites, you can use the Output I/O Control Panel to check the status of output devices. Click  to open the Output I/O Control Panel.

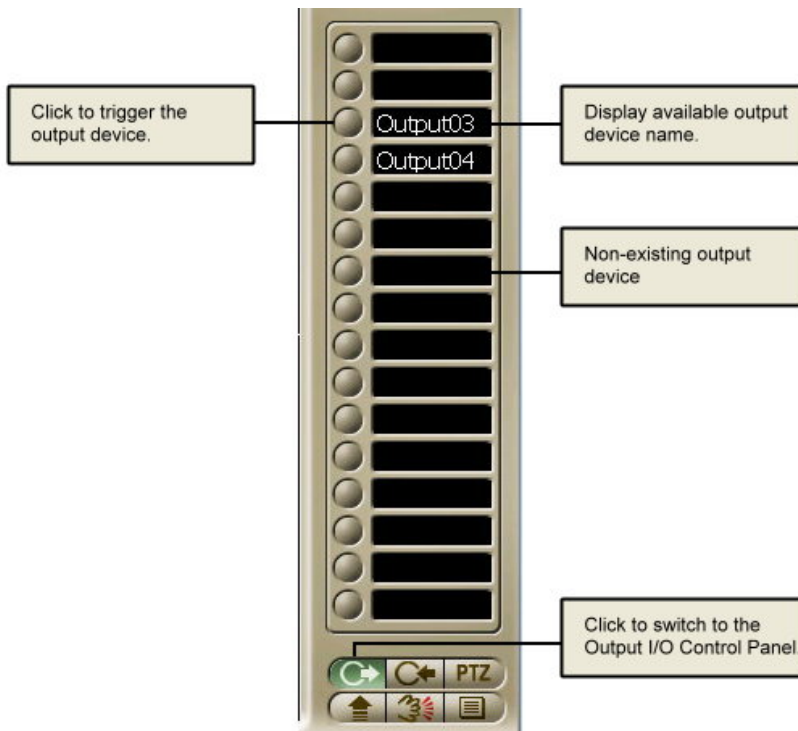

Using Remote Player

huperRemote's Remote Player lets you retrieve and view surveillance videos that have been digitally recorded by a DVR server. You can play back the recordings directly from the server over the Web, or you can download them first to your hard drive and play them locally on your computer. Surveillance video that you recorded locally on your computer hard drive can also be played in Remote Player. At most, surveillance video from 16 different video cameras that were recorded at the same time can simultaneously be viewed on-screen.

To change to the Remote Player screen, click  in the huperRemote program window.

The User Interface



- 1** Split-screen Window Shows the recordings from selected cameras, or shows a single recording only when a specific recording time from a camera is selected in the Camera List Panel.
- 2** DVR Site List Lists the URL addresses of remote DVR sites from which history records of video recordings can be retrieved.
- 3** Camera List Panel Lists the names of cameras in the currently selected DVR site. Under each camera, history records are listed by time. (See the next section for details).
- 4** Calendar Allows you to select the desired date of surveillance recording.
- 5** Play / Pause Click to start/pause the playback.
- 6** Navigation Panel Provides playback controls.
- 7** Audio Click to enable/disable audio during playback.
- 8** Preferences Click to define settings in the Preferences dialog box.
- 9** Back to huperRemote Click to change back to the huperRemote screen.

The Camera List Panel

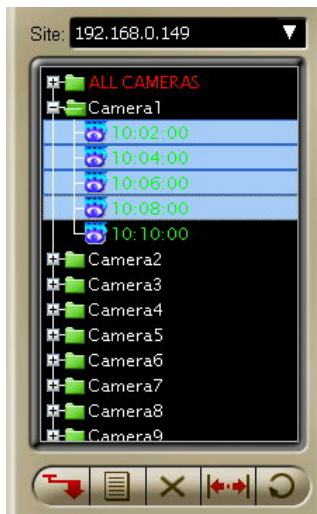



The Camera List Panel lists the names of remote cameras from a connected DVR site and displays the history records of the video recordings of these cameras. History records of a chosen date of recording will be displayed under each camera.

Panel Controls





 To download certain surveillance recordings for local playback from your hard drive, first choose the desired cameras and recording times in the Camera List Panel then click this button.

 Opens a menu where you can choose the type of history records to display in the Camera List Panel.

 Deletes selected history records from the Camera List Panel. If local history records are selected in the list, the video files will also be deleted from the hard drive.

While in the process of downloading video recordings, you can click this button to cancel the download.

 Click to define the desired range of history records to display in the Camera List Panel.

 Click to refresh the history records in the Camera List Panel.

The Navigation Panel

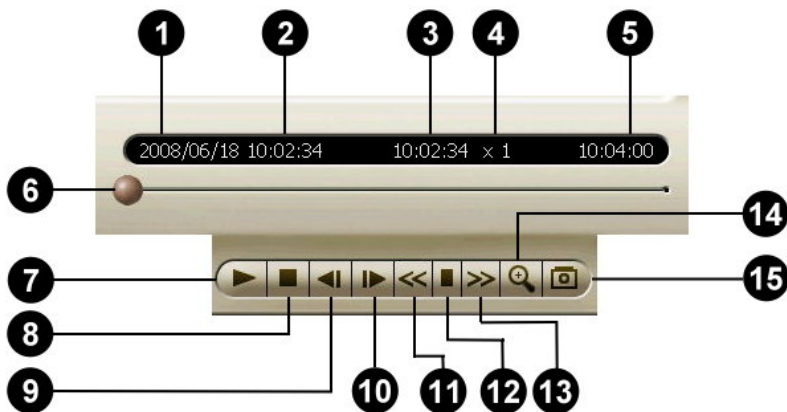

- 1** Date of history records Shows the calendar date of the history records that are listed in the Camera List Panel.
- 2** Start time Shows the start time of the selected record.
- 3** Current timecode Shows the timecode of the current video frame.
- 4** Current display speed Shows the currently used playback speed.
- 5** End time Shows the end time of the selected record.
- 6** Jog Bar Allows you to jump directly to any part of the recorded video. Drag the slider tab to the desired part of the recorded video.
- 7** Play / Pause Starts/Pauses the playback.
- 8** Stop Cancels the playback and moves to the starting frame.
- 9** Previous Frame Moves to the previous video frame. (Available for both single and multiple video recordings)
- 10** Next Frame Moves to the next video frame. (Available for both single and multiple video recordings)
- 11** Decrease display speed Slows down video playback. Click once to play the recorded video at half (1/2 x) the normal speed. Click again to play the video at a quarter (1/4 x) of the normal speed. The slowest speed is 1/8 x.

- 12** Normal display speed Plays the recorded video at its original speed.
- 13** Increase display speed Increases the playback speed of the video. Click once to double (2 x) the playback speed. Click again to quadruple (4 x) the playback speed. The maximum speed is 16 x.
- 14** Zoom in/out When playing video recordings, you can change the zoom ratio of the video by clicking this button.
To zoom in a video, first click the split screen that displays the video, then click this button. Click this button again to zoom out.
- 15** Snapshot Click this button to capture the current video frame and save it as a JPEG or BMP file.
To capture the current frame from a video, first click the split screen that displays the video, then click this button. This opens the Snapshot dialog box where you can enhance the image first before saving, printing, or sending it out by e-mail.

Viewing Recorded Video

To search for recorded surveillance videos and play them, there are four major steps that you need to do:

1. First, connect to the DVR server where the recordings are stored.
2. Choose the date of recording.
3. Specify the type of history records to access, then search and retrieve the history records.
4. If the recordings are stored in the DVR server, stream the videos from the server, or download them first for local playback from your hard drive.
Whereas if the recordings are locally stored in your computer, play back the videos from your hard drive.

The succeeding sections explain each of these steps in detail.

Connecting to a DVR Site



The DVR Site List keeps track of the URL addresses of DVR servers that you added to huperRemote. Select the URL address of the DVR server from this list. Remote Player then establishes connection with the DVR site and displays the names of its remote cameras in the Camera List Panel.

Selecting the Date of Recording

On the Calendar below the Camera List Panel, choose the desired date of video recording.

By default, the current month is displayed and the current date is highlighted in the Calendar. Green-marked dates on the Calendar indicate that there are video recordings on those dates.



To select the date of recording:

1. To change to another year, click the left or right double-head arrow repeatedly until you reach the desired year.
2. To change the month, click the left or right arrow single-head arrow repeatedly until you reach the desired month.
3. On the selected month, click the desired date.

Retrieving and Searching History Records

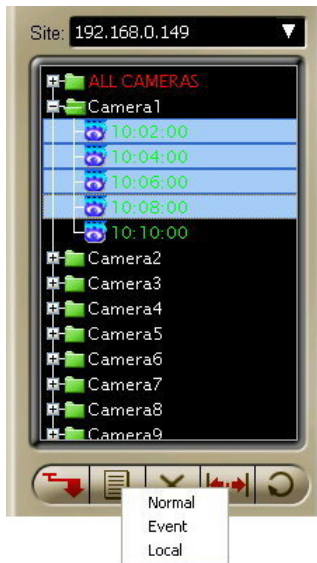

Before you can retrieve, download and play back surveillance video recordings from a DVR site, you first need to specify the type of history records to access. After you have connected to a DVR server and selected a calendar date, click . A pop-up menu then opens, displaying three types of history records of surveillance video recordings: Normal, Event, and Local.

Normal Lists the history records of all surveillance videos that were recorded during the selected calendar date.

Event Lists the recording time of events only.

Local Lists the recording time of surveillance videos that were recorded and stored in the local hard drive.

History records of the selected type will then be retrieved from the DVR server or your local drive and then displayed in the Camera List Panel.

Retrieving a Specified Range of History Records

If you chose "Normal" or "Event" as the type and the retrieved history records are quite long, you can limit the history list by specifying a desired range.

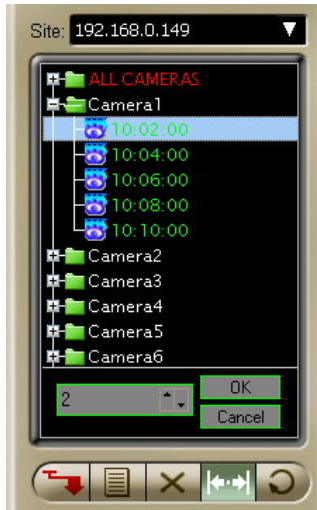

To specify a range of "Normal" history records:

1. Click . A time interval text box will then appear at the bottom of the Camera List Panel.
2. By default, Normal-type history records are listed in intervals of one hour. To change the interval, click the Up/Down arrow button or enter the desired time interval.
3. Click OK to confirm the change. (To retain the original interval, click Cancel.)

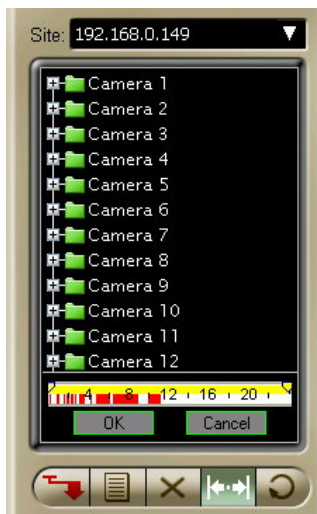

To specify a range of "Event" history records:

1. Click . A time ruler will then appear at the bottom of the Camera List Panel.
2. By default, all Event-type history records on the selected calendar date will be retrieved and listed in the Camera List Panel. To limit the history list to a certain time period, drag the two handles on the time ruler to set the desired start and end time.
3. Click OK to confirm the change. (To keep the original history list, click Cancel.)

Playing the Video Recordings

After you have retrieved the desired history records of surveillance video recordings, you can now play and view them on Remote Player.

If you retrieved Normal-type or Event-type history records, you can play the videos directly from the DVR server by streaming. However, if your Internet bandwidth is slow or overloaded, it is recommended that you download the video recordings first to your computer for local playback from your hard drive.

If you retrieved Local-type history records, the videos from these history records are locally stored in your computer. You can just play back the videos directly from your hard drive.

To play back recordings from a DVR server:

1. Click  and choose the type of history records from which to retrieve video recordings. To retrieve all recordings of the selected calendar date, select Normal. Otherwise, to retrieve only the recordings of events, select Event.
2. To view a single video recording only, click the "+" to display first the history records of a desired camera. Then, click the time segment of the recording that you want to view.

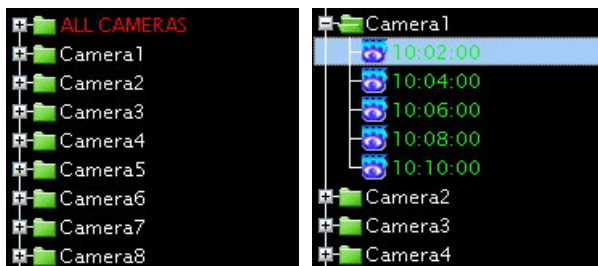

If you want to view multiple video recordings simultaneously, hold the [Shift] or [Ctrl] key then click the time segments of recordings that you like to view.

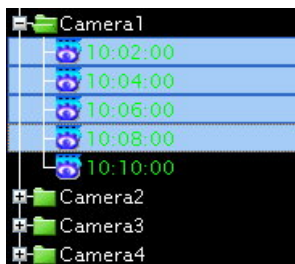

3. To download the video recordings first to your local hard drive, click . If you want to directly stream the video recordings from the DVR server, go to the

next step.

4. Click  to play the video.

This allows you to view the video from start to finish. To pause playback, click this button again.

5. To scrub through the video, drag the Jog bar. You can also use the other controls in the Navigation Panel to move back and forth through the video. (See "The navigation Panel" for details on the different button controls of the Navigation Panel).

To play back recordings in the local drive:

1. Click  then select Local.
2. To view a single video recording only, click the "+" to display first the history records of a desired camera. Then, click the time segment of the recording that you want to view.

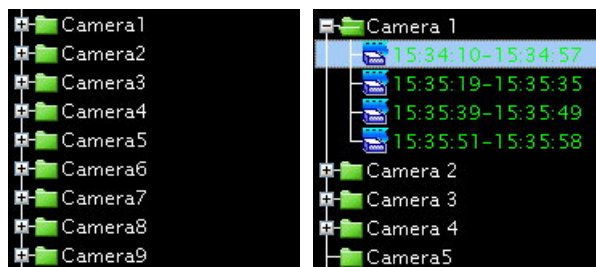

If you want to view multiple video recordings simultaneously, hold the [Shift] or [Ctrl] key then click the time segments of recordings that you like to view.

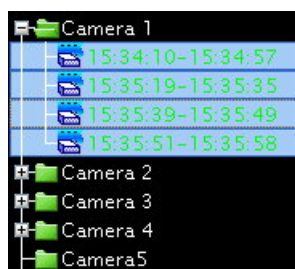

3. Click  to play the video.

This allows you to view the video from start to finish. To pause playback, click this button again.

4. To scrub through the video, drag the Jog bar. You can also use the other controls in the Navigation Panel to move back and forth through the video.

Capturing Image Snapshots

If a video recording clearly shows suspicious activities or an intruder in the monitored site, you can notify police authorities and provide them with actual image snapshots.

To take a snapshot:

1. First, play back the recorded video, then click .
2. The Snapshot dialog box then opens, allowing you to enhance the captured image first before saving, printing or sending the image by e-mail.
3. To enhance the image, drag the Brightness, Contrast and Saturation sliders until you get desirable results.
4. To save the image, click the Save button. The Save To dialog box then opens. Type in the file name to use for saving the image and choose whether to save it in JPEG or BMP format. Then, click Save.

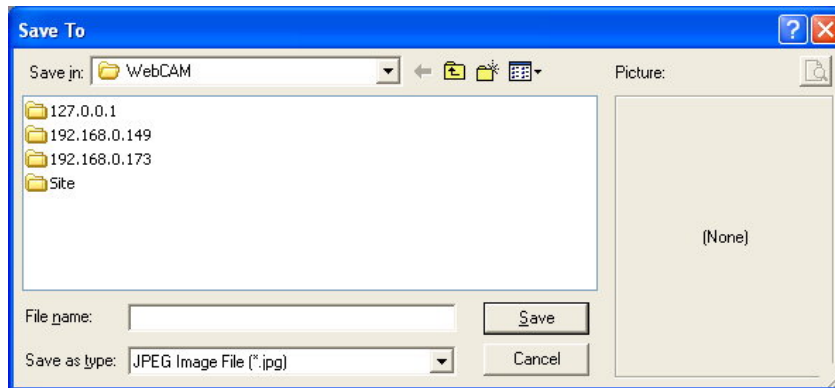
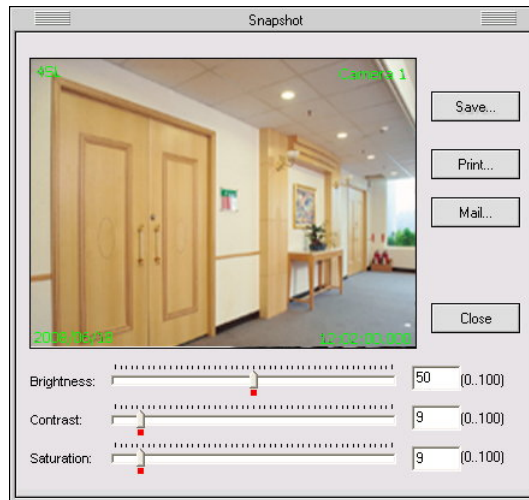

5. If you want to print a hardcopy of the image, click the Print button.

Note: When you click Print and you don't have a printer installed, it will prompt a message asking you if you want to install a printer first.

6. To send the image by e-mail, click the Mail button. Your default e-mail program will then open, with the image file automatically attached to a new e-mail message. Enter the recipient's e-mail address, and type in the subject and body of your e-mail message then send it.



Using the Scheduler

huperRemote can be configured to record surveillance videos on a regular basis. It has a built-in Scheduler that allows you to set up specific day and time schedules for continuous recording of surveillance video from remote cameras on your local drive.

Before opening the Scheduler, you first need to connect to the DVR sites that you want to set up recording schedules for.

Setting up the Recording Schedule

To set up a regular schedule for video recording:

1. In the huperRemote program window, click  to open the Connect dialog box and connect to a DVR site.
Or, if you are already connected to a DVR site, click the site name in the Camera List Panel to select the site.
2. Click  to open the Scheduler.
3. In the Scheduler dialog box, the names of the remote cameras on the DVR site will be displayed. Choose the remote cameras that you want to record video from by clicking the check boxes at the left side of the camera names.
Selected cameras are indicated by a check mark on check boxes.
4. The numbers that are lined up in columns represent the hours of a day. For each selected camera, choose the desired hours when you want surveillance video to be recorded by clicking the boxes underneath the hour columns.

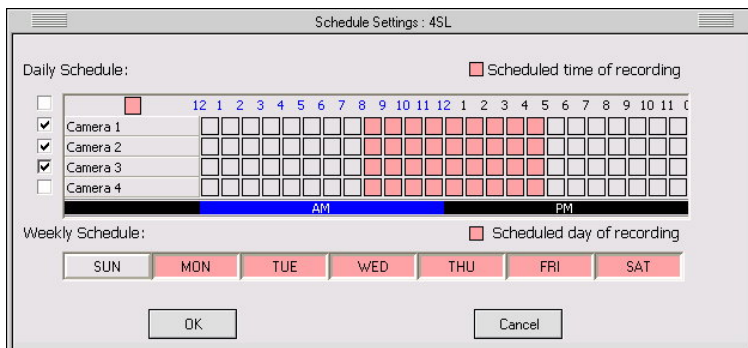

Selected hours are indicated by color boxes. Non-selected (or deselected) hours are indicated by gray boxes.

5. Next, choose the days of the week when you want surveillance video to be recorded by clicking the buttons containing the names of the days of the week. Selected days are indicated by colored buttons. Non-selected (or deselected) days are indicated by gray boxes.
6. When you have finished setting up the cameras and the time and day of recording, click OK.
7. Repeat steps 1 to 6 to set up the recording schedule for another DVR site.

Removing Schedules

There are three alternative ways you can do to remove some or all of the set recording schedules.

To remove recording times or days in Scheduler:

Click  to open the Scheduler. In the Scheduler dialog box, deselect the unwanted hours or days of the week.

To remove recording times or days in Preferences:

Click  to open the Preferences dialog box, then click Downloads & Schedules. (See the image below). This part of the Preferences dialog box lists the recording times per scheduled day and the current recording status. (The entries in the list that show a clock icon indicate that they are scheduled times of recording).

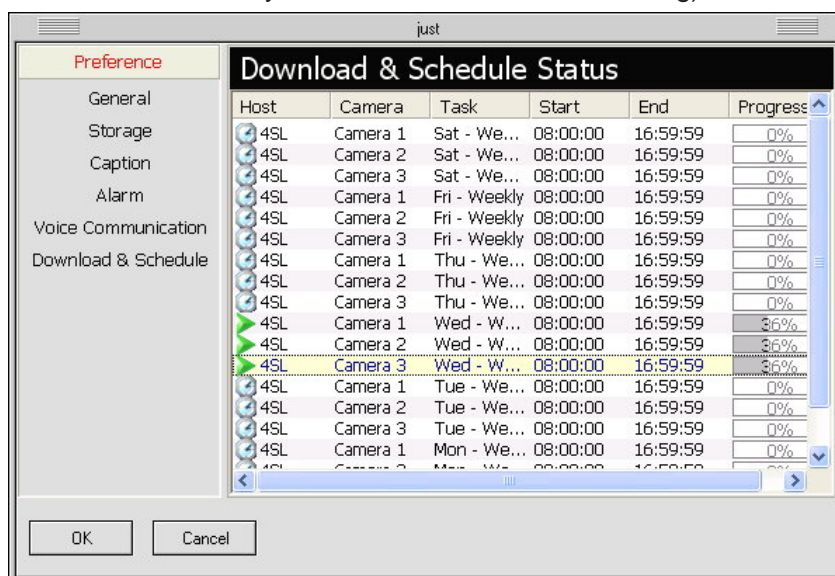

To remove a recording time, right-click the entry that shows the camera name and the unwanted recording "Start" time. Then in the pop-up menu that appears, click DELETE SELECTED.

To remove several entries from the list, press Ctrl and click each unwanted entry. Multiple-selected entries will be highlighted in yellow. To remove them, right-click and then click DELETE SELECTED.

To cancel all scheduled recordings:

Click  to open the Preferences dialog box, click Storage, then click Cancel Schedules.

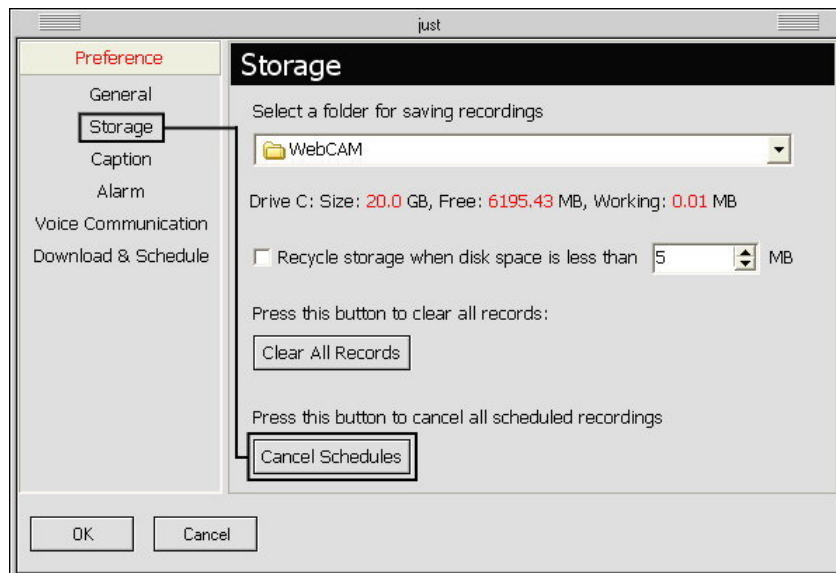

Configuring huperRemote

Click  in the huperRemote program window to open the Preferences dialog box where you can set up the working environment for the huperRemote program. You can choose to enable disk storage recycling for video recordings, enable/display caption display on split screens, set up alarms in your local computer when there are detected events, and more.

Preferences Dialog Box

General

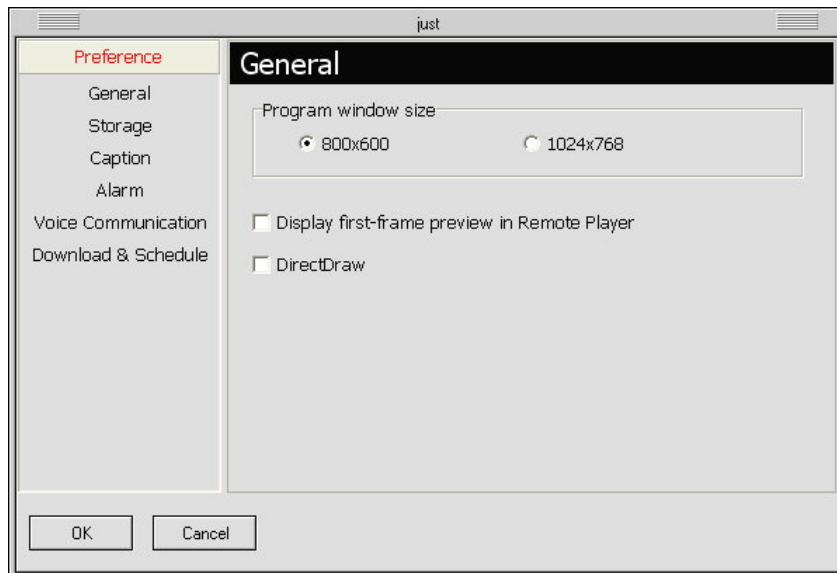

Program window size

Choose the appropriate program window size for huperRemote based on the resolution of your Windows display.

Display first-frame preview in Remote Player

When this option is selected, the first frame of each of the video recordings you chose in Remote Player's Camera List Panel will be shown. This gives you a preview image of each selected video recording.

DirectDraw

Use DirectDraw Engine to display video. This option can reduce CPU consumption and use anti-alias feature. Please make sure your system can support DirectDraw function before checking this option.

Storage

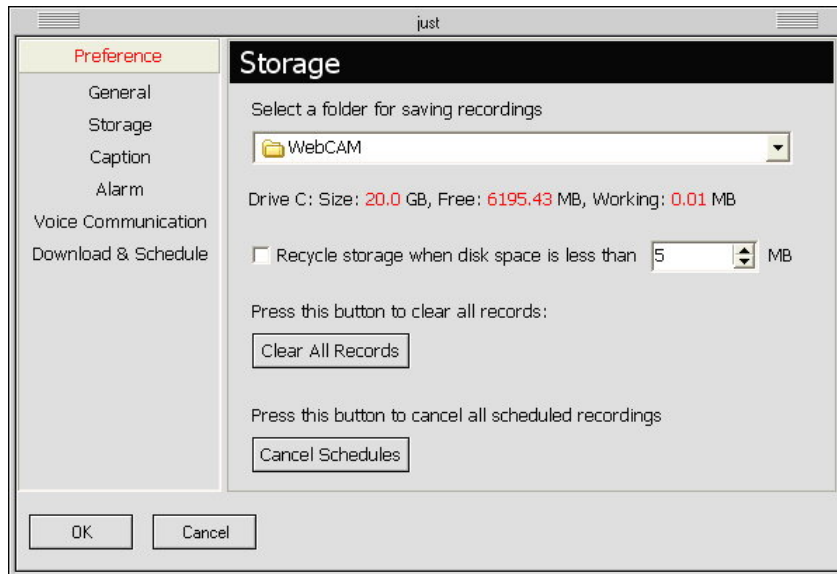

Select a folder for saving recordings

Click the drop-down arrow button to browse through your hard drive, then choose a working folder where to save locally recorded videos and downloaded recordings.

Drive (Size, Free, Working)

This indicates your local hard drive capacity, the remaining disk space, and the amount of disk space already used.

Recycle storage when disk space is less than

When this option is selected, old video recordings will be deleted when the hard disk space has reached the specified limit. This will free up hard disk space for saving new recordings.

Clear All Records

In the text box provided, set the disk space limit.

Click this button to delete all video recordings from the working folder in your local hard drive.

Cancel Schedules

Click this button to cancel all scheduled recordings.

Caption

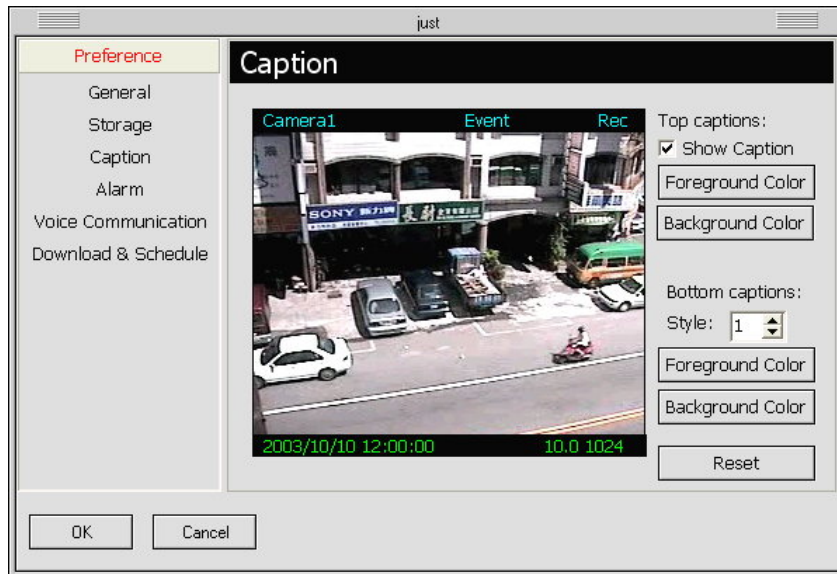

Top captions

These are the captions that appear on top of the split-screen windows. They display the camera name, detected event, and recording status.

- Show caption When this option is selected, the top captions will be displayed on the split-screen windows. To hide these captions, clear this option.
- Foreground Color Click this button to set the text color for the captions.
- Background Color Click this button to set the color of the text bar.

Bottom captions

These are the captions that appear at the bottom of the split-screen windows. They display the date and time, average frame rate, and data rate.

- Style There are four display styles for the bottom captions:
 Style 0: Hides the captions.
 Style 1: Displays the captions with a text bar.
 Style 2: Displays the captions without a text bar.
 Style 3: Displays the captions in outline style.
- Foreground Color Click this button to set the text color for the captions.
- Background Color Click this button to set the color of the text bar.

Reset

Click this button to change back to the default settings.

Alarm

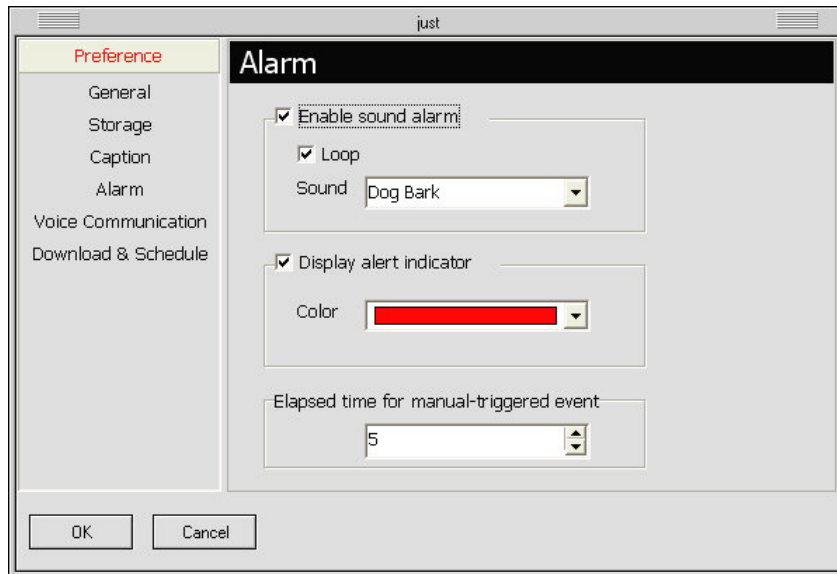

Enable sound alarm

Select this option if you want your computer to sound an alarm when there is a detected event.

- Loop
- Sound

When this option is selected, your computer will sound the alarm continuously.

Click the drop-down arrow button then choose the type of sound to use as the alarm.

Display alert indicator

Select this option if you want a blinking alert indicator to be displayed on the split-screen window when there is a detected event.

- Color

Click the drop-down arrow button, then choose a color to use for the alert indicator.

Elapsed time for manual-triggered event

Set the time duration for manually triggered events (initiated from your local computer to the remote camera).

Voice Communication

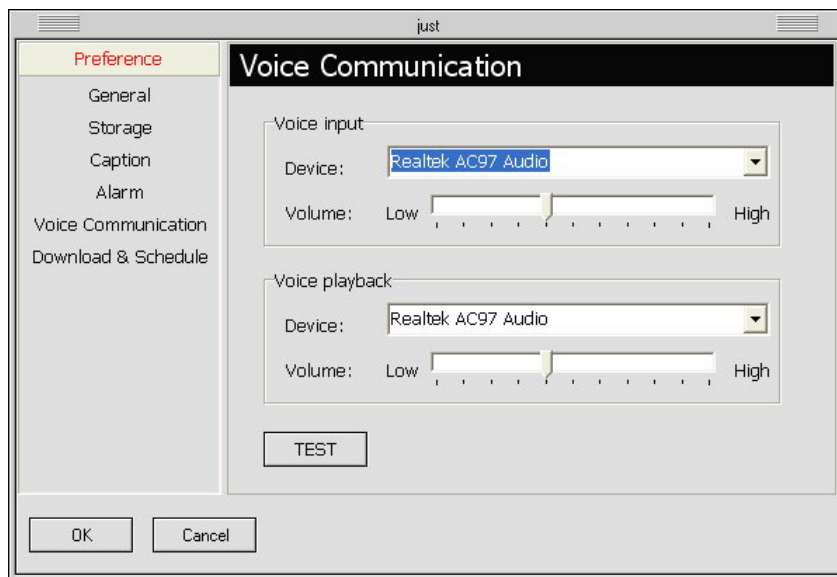

Voice input

- **Device** Displays the audio device used by your input device (e.g. microphone) to capture your voice. If you have more than one audio device installed, select the device you want to use from the drop-down menu.
- **Volume** Drag the slider to adjust the input device's volume.



Voice playback

- **Device** Displays the audio device used by your playback device (e.g. speakers) to play back the voice from your counterpart. If you have more than one audio device installed, select the device you want to use from the drop-down menu.
- **Volume** Drag the slider to adjust the playback device's volume.

TEST Click this button to test the volume of the voice input/ output device.

Downloads & Schedules

The Downloads & Schedules section in the Preferences dialog box displays two types of information:

-  The entries that are indicated by a "clock" icon are the preset schedules for video recording.
-  The entries that are indicated by a "play" icon are either scheduled recordings which are currently in progress, or file downloads which are in progress.

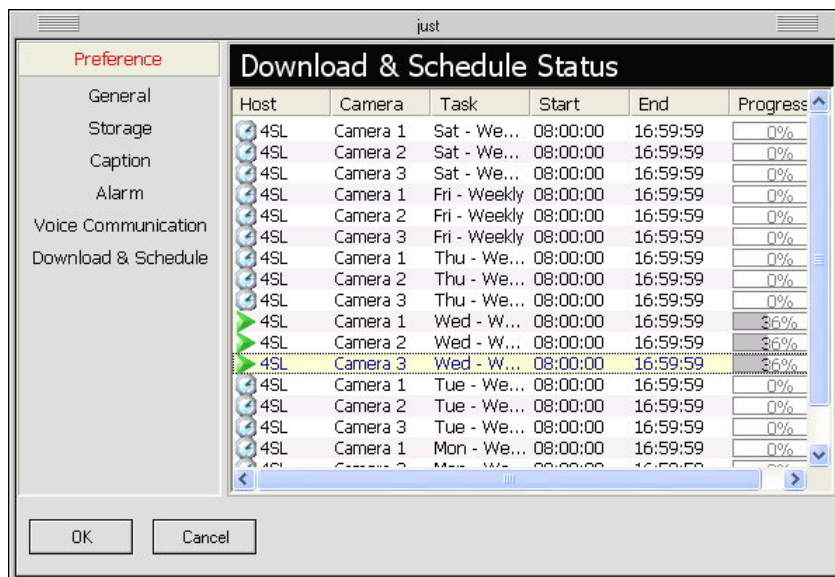

When you select an entry and then right-click on it, a pop-up menu will appear. From this menu, you can delete a schedule, show or hide the information list, cancel a scheduled recording, or terminate a file download.

The columns in the information list show the following:

- Host** Shows the name of the remote server.
- Camera** Shows the name of the remote camera.
- Task** Shows the preset recording schedule.
When downloading, this column shows "HTTP" to indicate that the file is being downloaded via the Internet.
- Start** Shows the start time of a schedule, or the start time of a video recording.
- End** Shows the end time of a schedule. or the end time of a video recording.
- Progress** Shows the current progress of a scheduled recording or file download (in percentage).

Chapter 6

Remote Viewer

Remote Viewer allows you or any user to view remote video cameras, control remote PTZ cameras, remotely record videos on the local drive, talk with another person through two-way voice communication and play back video recordings on the local drive via a Web browser. Users who have user accounts in the Site Server that are assigned with at least the "Remote User" privilege level can access cameras remotely over the Internet, Intranet, or through direct modem connection.

Using Remote Viewer through an Internet connection

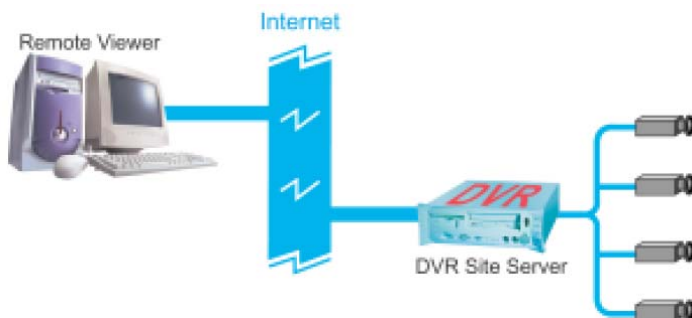

Launch Remote Viewer by clicking Start - Programs - Remote Viewer HV v1.10 - Remote Viewer. When the program opens, click the  button to open the "Log In" dialog box and configure the settings to be able to connect to the DVR site server using an Internet connection.

To configure the settings in the "Log In" dialog box:

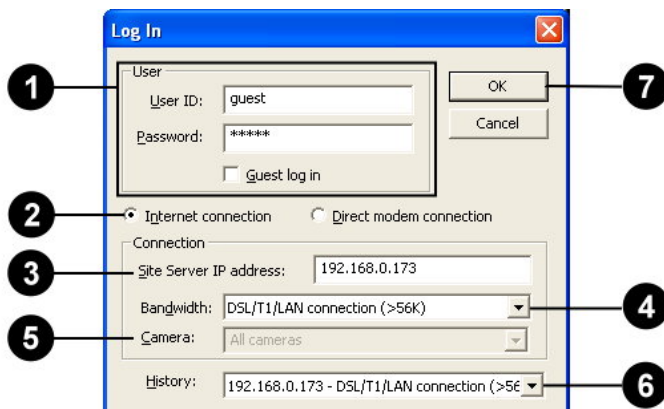

1. Enter a valid user ID and password.

Note: If the remote DVR Site Server does not enable the access control, select the "Guest log in" check box.

2. Select "Internet connection."
3. Enter the IP address or domain name of the remote DVR Site Server.
4. Select the bandwidth speed of the Internet connection.
5. By default, All cameras is selected.
6. You can select a past connection from the drop-down list to fill out the Connection information.
7. Click OK to connect to the DVR site server.

After clicking OK, you should be able to see live video feed from the remote camera(s) on the split screen display.

Note:

1. Before using Remote Viewer through an Internet connection, make sure that the remote DVR Site Server has "Allow remote access" and "Enable Web server" selected in Preferences - General tab (valid TCP port must also be entered), the DVR machine has been assigned a unique IP address, and your client machine that runs Remote Viewer can connect to the Internet.
2. The Web browser version you have should either be Microsoft Internet Explorer version 5.5 or a later version.

Using Remote Viewer through a direct modem connection

Direct Modem Connection is a connection between two modem devices through the General Telephone System that allows users to view remote cameras. Follow the steps on the next page to set up the direct modem connection at the DVR Site Server machine and a remote client machine."

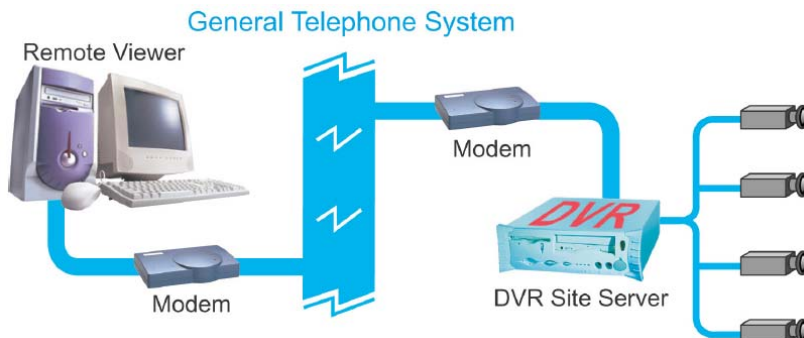

Setting up the DVR Site Server machine

1. Install a modem device (card) to the DVR machine if the machine doesn't have a modem installed.
2. Connect a valid telephone line to the "Line" port of modem device (card).
3. Set up an advanced connection in Windows for receiving incoming calls. Please refer to the section "How to set up an Advanced Connection" for the details.

Make sure to assign a fixed IP address to your LAN card, whether it is a global IP address or a local IP address. If you don't want to assign a fixed IP address to your LAN card, try to disable the LAN card when enabling the direct modem connection.

Setting up a client machine for remote watch

1. Install a modem device (card) to the client machine if the machine doesn't have a modem installed.
2. Connect a valid telephone line to the "Line" port of modem device (card).
3. Install the Remote Viewer program from the product CD.

Building a direct modem connection

Launch Remote Viewer by clicking Start - Programs - Remote Viewer HV v1.2 – Remote Viewer. When the program opens, click the  button to open the "Log In" dialog box and configure the settings to be able to connect to the DVR site server using a direct modem connection.

To configure the settings in the "Log In" dialog box:

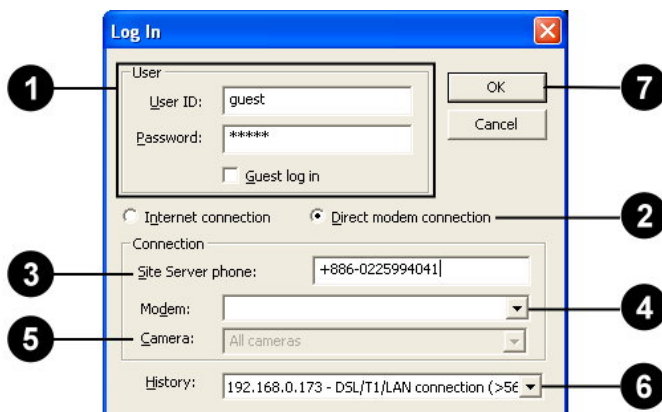

1. Enter a valid user ID and password.

Note: If the remote DVR Site Server does not enable the access control, select the "Guest log in" check box.

2. Select "Direct modem connection."
3. Specify the telephone number of the DVR Site Server that you want to watch via remote.
4. Specify the modem driver at the local machine.
5. By default, All cameras is selected.
6. You can select a past connection from the drop-down list to fill out the Connection information.
7. Click OK to connect to the DVR site server.

After clicking OK, you should be able to see live video feed from the remote camera(s) on the split screen display.

Setting up an Advanced Connection

For Windows XP

1. Plug a modem device into a COM port of the DVR Site Server machine.
2. Install the driver for the modem device.
3. Click the "Start" button on your Windows taskbar and select "Control Panel" to open the Control Panel window.

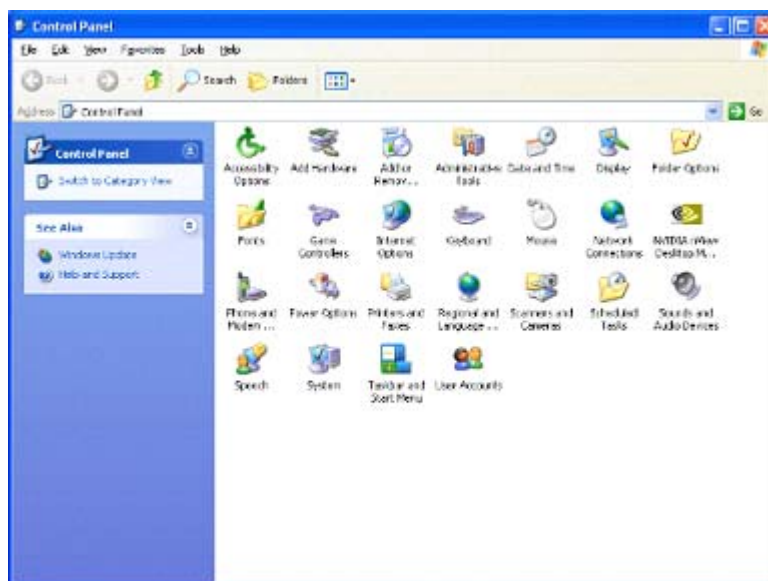

4. Click the "Network Connections" icon in the "Control Panel" window to open "Network Connections" window.

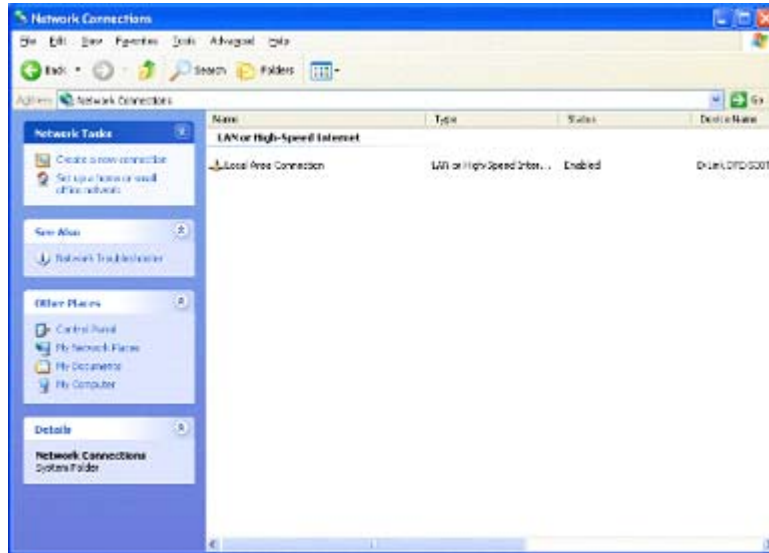

Note: If the "Location Information" dialog box opens, please fill in the area code and the telephone number of the telephone line connected to the modem.

5. Click the "Create a new connection" item to launch the "New Connection Wizard" window. Click the "Next" button.



6. Select the "Set up an advanced connection" option then click the "Next" button.



7. Select the "Accept incoming connections" option then click the "Next" button.



8. In the "Connection devices" list, select the modem driver then click the "Next" button.



9. Select the "Allow virtual private connections" or "Do not allow virtual private connections" option then click the "Next" button.



10. Click the "Add" button to open the "New User" dialog box.



11. Type in "DVR" for "User name", "Password" and "Confirm password" then click the "OK" button to close the dialog box. Click the "Next" button.

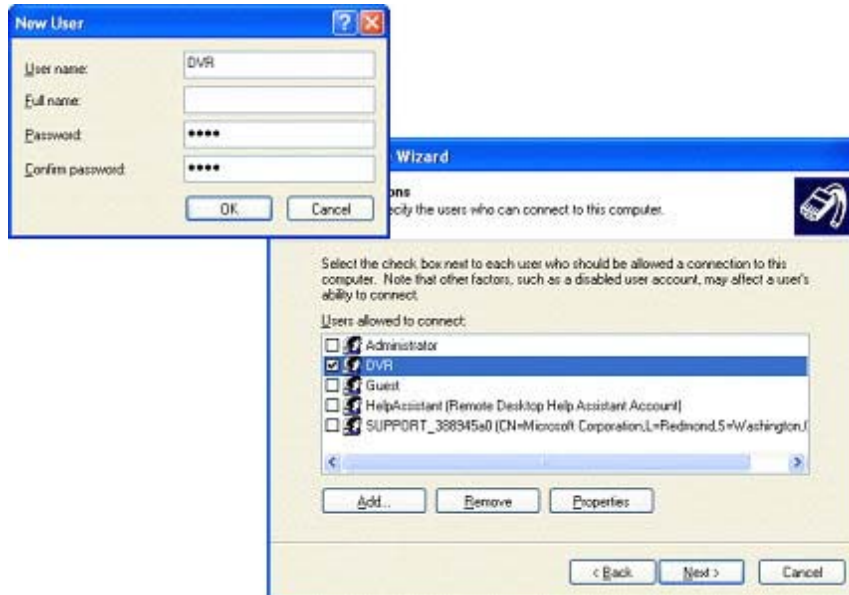

12. In the "Networking software" list, select the "Internet Protocol (TCP/IP)" item and click the "Properties" button to open the "Incoming TCP/IP Properties" dialog box.



13. Select the "Allow calling computer to specify its own IP address" option then click the "OK" button to close the dialog box.

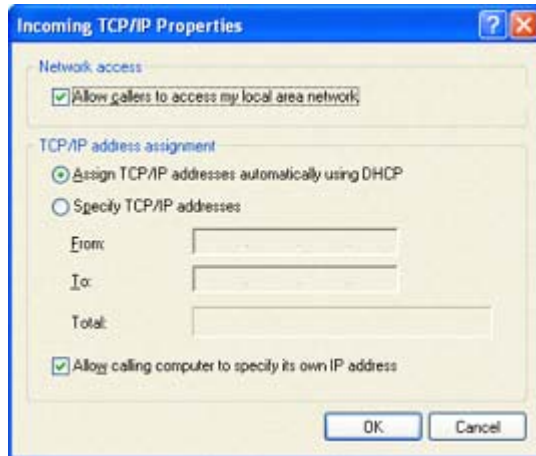

14. Click the "Next" button then click the "Finish" button to complete the setup process.



For Windows 2000

1. Plug a modem device to a COM port of DVR Site Server machine.
2. Install the driver for the modem device.
3. Click the "Start" button then select Settings > Network and Dial-up Connections > Make New Connection to open the "Network Connection Wizard" dialog window.
Click the "Next" button.

Note: If the "Location Information" dialog box opens, please fill in the area code and the telephone number of the telephone line connected to the modem.

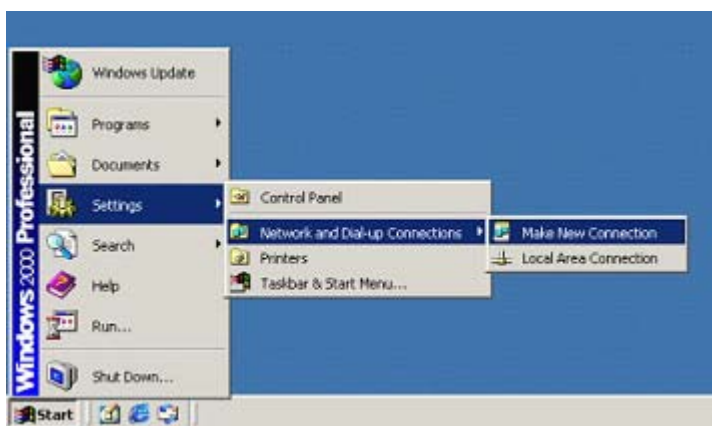

4. Select the "Accept incoming connections" option then click the "Next" button.



5. In the "Connection devices" list, select the modem driver then click the "Next" button.

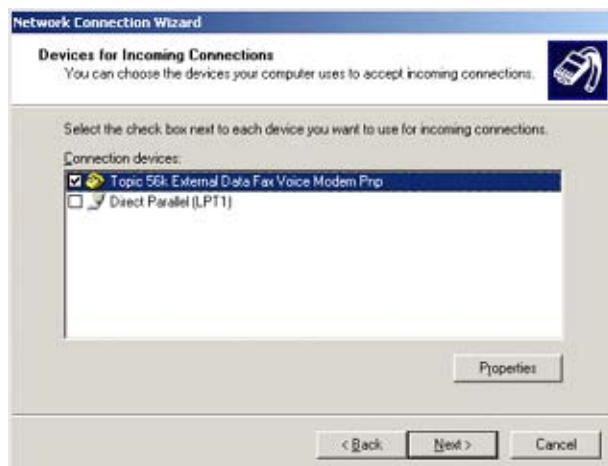

6. Select the "Allow virtual private connections" or "Do not allow virtual private connections" option then click the "Next" button.

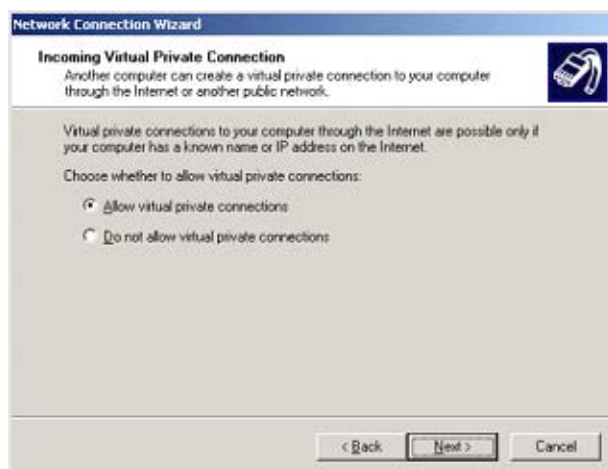

7. Click the "Add" button to open the "New User" dialog.

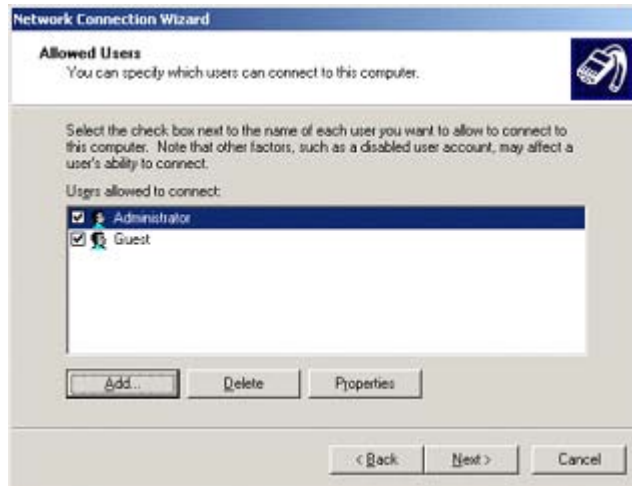

8. Type in "DVR" for "User name", "Password" and "Confirm password" then click the "OK" button to close the dialog box. Click the "Next" button.

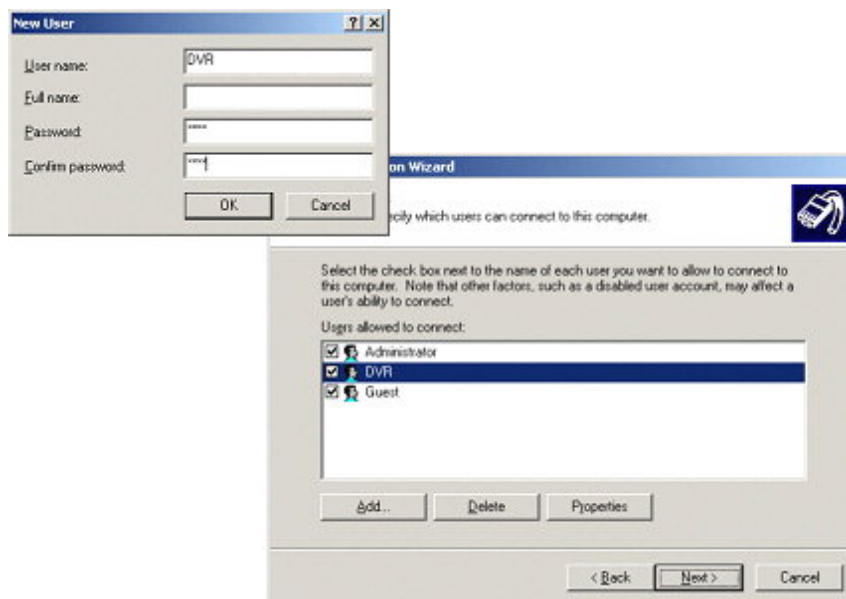

- In the "Networking components" list, select the "Internet Protocol (TCP/IP)" item and click the "Properties" button to open the "Incoming TCP/IP Properties" dialog box.

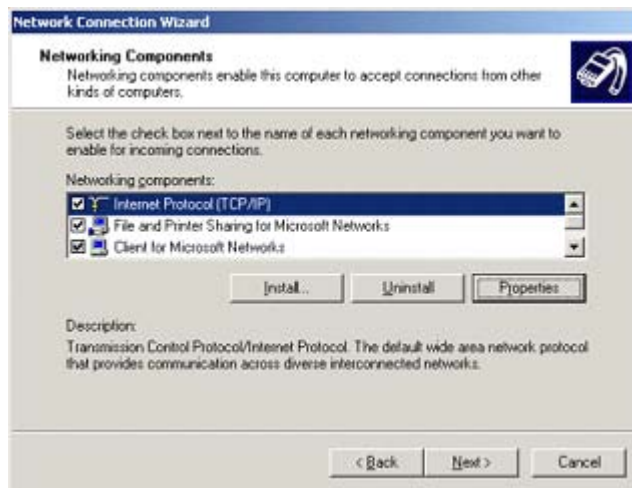

- Select the "Allow calling computer to specify its own IP address" option then click the "OK" button to close the dialog box.

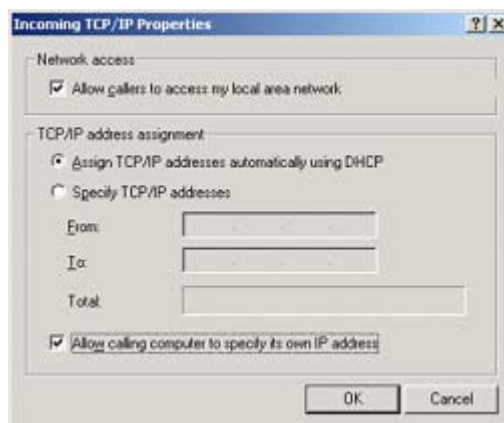

- Click the "Next" button then click the "Finish" button to complete the setup procedure.



The Operations of Remote Viewer

This Multi-screen Display can have up to 16 split screens to show live video from video cameras on the remote DVR site.

Use the Camera Control Panel to select a camera, connect/disconnect a camera, control PTZ camera, and record video. (See Camera Control Panel" for more details.)

Use the General Control Panel to choose how split screens are displayed, enable voice communication, play recorded video and customize preferences settings. (See General Control Panel" for more details.)

Click this button to connect to a remote DVR site.

Split screens

Each split screen on the Remote Viewer interface shows the camera name and the current status of the video camera.

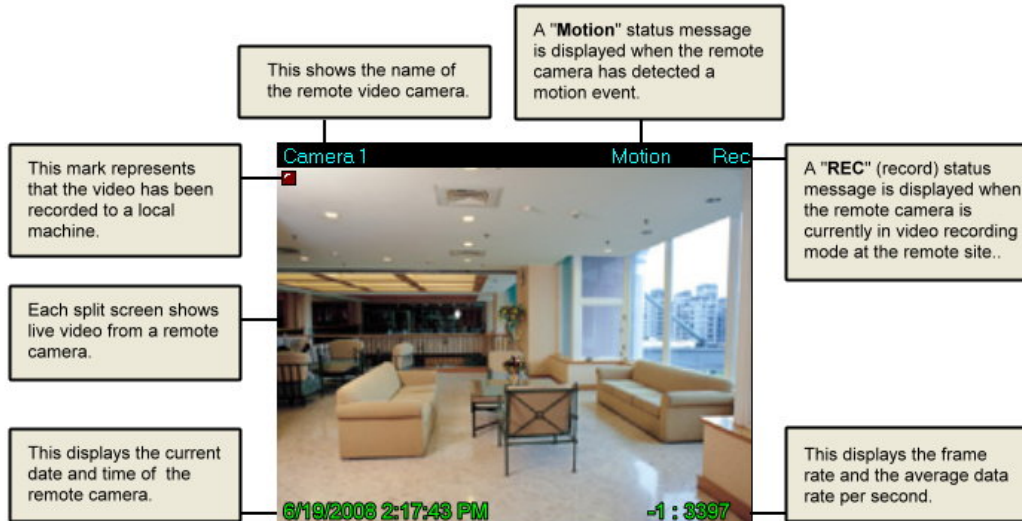

Camera Control Panel

The Camera Control Panel provides button controls for connecting to the remote site, selecting/viewing remote cameras, and controlling PTZ cameras.

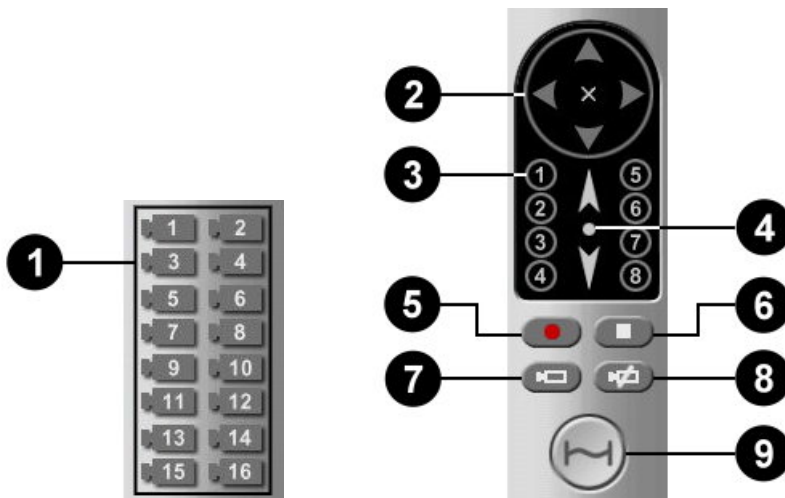

- 1** Camera buttons Click a camera button to select the corresponding remote camera. You need to select a remote camera first to record camera video, control a PTZ camera, or connect/disconnect the camera.
- 2** Pan & Tilt control This is the Pan and Tilt control. Click one of the four arrow buttons to adjust the camera angle up, down, left, or right. Click the "cross" button to stop movement.
- 3** Preset buttons The number buttons are Preset buttons. Click a button to move the PTZ camera to the position and angle position specified by the preset button.
- 4** Zoom control Click the up arrow to zoom in, or the down arrow to zoom out. If the PTZ camera does not provide zoom scaling feature, click the up or down arrow continuously to zoom in or out. Click the circle button to stop zooming.
- 5** Record button Click this button to start recording video from the selected camera.
- 6** Stop button Click this button to stop recording the video from the selected camera.
- 7** Connect Camera button Click to display the "Log In" dialog box to connect to the selected remote camera.
- 8** Disconnect Camera button Click to disconnect the selected camera.
- 9** Connect Site button Click to display the "Log In" dialog box to connect to a remote DVR site. Click again to disconnect all camera connections.

General Control Panel

The General Control Panel provides button controls for switching between 1/4/9/16 split screens display, playing video recordings, and customizing preference settings.

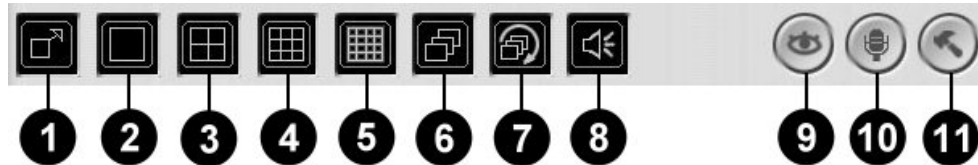

- 1** Full Screen button Toggles between full-screen and normal display mode.
- 2** Single View button Click to display the split screen in single view.
- 3** 4 Split Screens button Click to split the Multi-screen display into 4 split screens.
- 4** 9 Split Screens button Click to split the Multi-screen display into 9 split screens.
- 5** 16 Split Screens button Click to split the Multi-screen display into 16 split screens.
- 6** Next Page button If there are more active video cameras than the selected split screen view, click to display the next set of video feed from the cameras.
- 7** Loop Page button If there are more active video cameras than the selected split screen view, click to loop the video feed from the cameras on the split screens.
- 8** Live Sound button Click to listen to live audio that is associated with camera in the remote site.
- 9** Record List button Click to display the list of video recordings.
- 10** Talk button Click to enable the two-way voice communication to a remote DVR site. Click again to disable it. If there is a camera selected, the target of the voice communication is to the DVR site where the selected camera is on. If there is no camera selected, the first connected camera's DVR site is the target of the voice communication.
- 11** Preferences button Click to open the Preferences dialog box.

Preference Settings

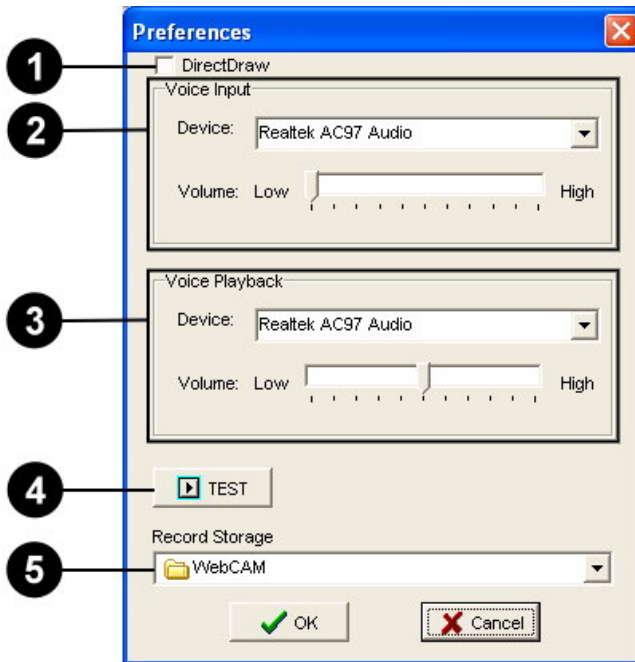

- 1** DirectDraw Use DirectDraw Engine to display video. This option can reduce CPU consumption and use anti-alias feature. Please make sure your system can support DirectDraw function before checking this option.
- 2** Voice Input Displays the audio device used by your input device (e.g. microphone) to capture your voice. You can also adjust input device's volume here. If you have more than one audio device installed, select the device you want to use from the drop-down menu.
- 3** Voice Playback Displays the audio device used by your playback device (e.g. speakers) to play back the voice from your counterpart. You can also adjust the playback device's volume here. If you have more than one audio device installed, select the device you want to use from the drop-down menu.
- 4** Test button Press the button to test the volume of the voice input/ output device.
- 5** Record Storage Specify the folder where you want to save video recordings.

Connecting to multiple cameras from different DVR Site

Servers

1. Install the Remote Viewer program in your client machine.
2. Launch the Remote Viewer program.
3. Click a split screen.
4. Click the “Connect Camera” button to launch the “Log in” dialog box.
5. Enter the site server information and select a camera that you want to view.
6. Click the “OK” button in the “Log in” dialog box to connect.

Repeat steps 3-5 to connect to other cameras. At most, you can connect to 16 cameras from 16 different DVR Site Servers.

Controlling the DVR Site Server desktop remotely

1. Provide a password to the Administrator account in Site Server.
2. Install the Remote Viewer program in your client machine.
3. Launch the Remote Viewer program.
4. Click a split screen.
5. Click the “Connect Camera” button to launch the “Log in” dialog box.
6. Enter the site server information, administrator account and password.
7. Select “Control” from the Camera list.
8. Click the “OK” button in the “Log in” dialog box to connect.

If you want to view the DVR Site Server desktop in full screen, switch to the single view layout then select full screen as the display mode.

Viewing recorded videos

When recording surveillance videos from remote cameras, Remote Viewer saves them on the local computer's hard drive. To retrieve and view the recorded videos, click the  button. A Record list window then appears, displaying logs of video recordings.

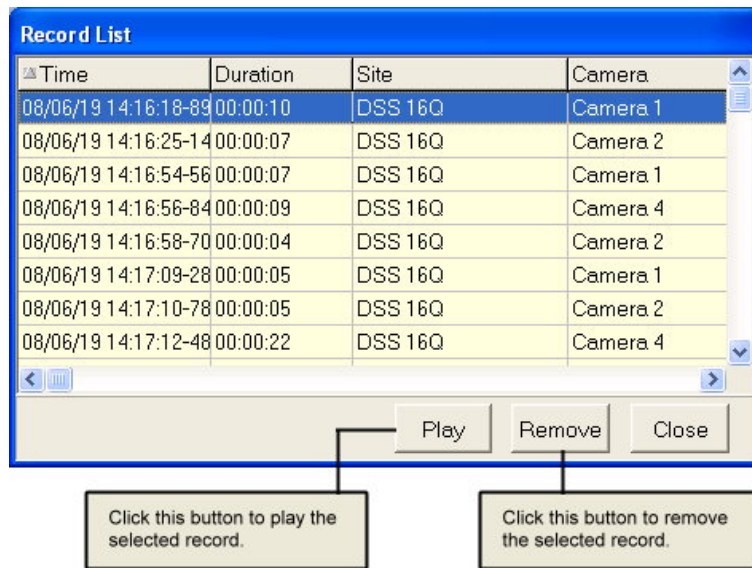

Select a log entry that shows details about the recorded surveillance video you want to view. Then click the Play button to open the Playback Web page and play back the recorded video.

Playback Web page

The Playback Web page allows you to control the playback of the selected recorded video and take an image snapshot.



- | | | |
|---|-----------------------|---|
| ❶ | Displayed information | This shows the remote site name and camera name. |
| ❷ | Date and Timecode | This shows the recording date and timecode of the current video frame. |
| ❸ | Navigation controls | The buttons from left to right are: "Play", "Pause", "Stop", "Previous Frame" and "Next Frame". |
| ❹ | Snapshot button | Click this button to capture the current video frame, save it as a JPEG file, and then display it on the Snapshot Web page. |

Snapshot Web page

The Snapshot Web page displays the captured image. The site name, camera name, date and timecode are shown on the image. Press the Print button to send the image out to a printer.

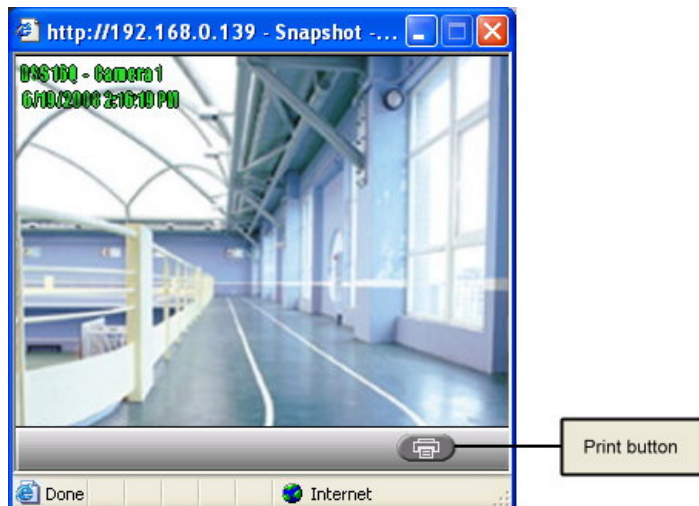

Chapter 7

Remote Record Player

Remote Record Player allows you to download video recordings from a remote DVR site server and then view them on your local computer. Only downloaded video recordings from a remote DVR site server can be played back in Remote Record Viewer.

Launching Remote Record Player

Launch Remote Record Player by clicking Start - Programs - Remote Viewer HV v1.10 - Remote Record Player.

Program Interface: An Overview

The program is like a video player. These are the controls that you need to download and play back video recordings.

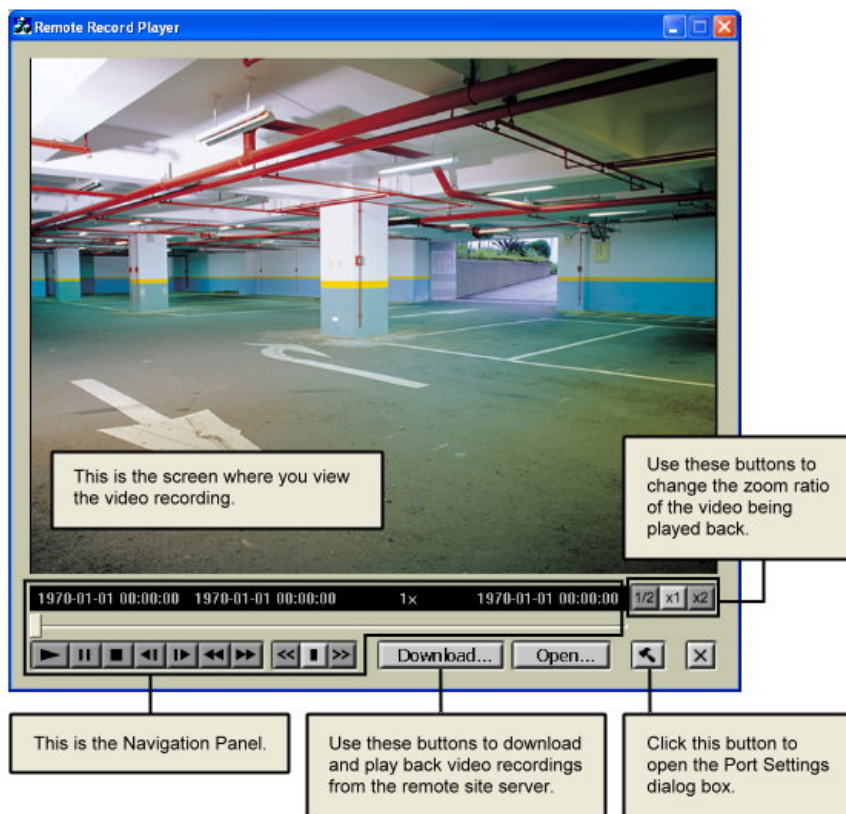

Downloading and Playing Back Video Recordings from a Remote Site Server

You can download video recordings from a remote site server to your local computer then play it back. You may need access rights to the remote site server to be able to download video recordings.

Configuring port settings

Click the “Preference” button to open the “Port Settings” dialog box where you can configure Remote Record Player to connect to the DVR site server.

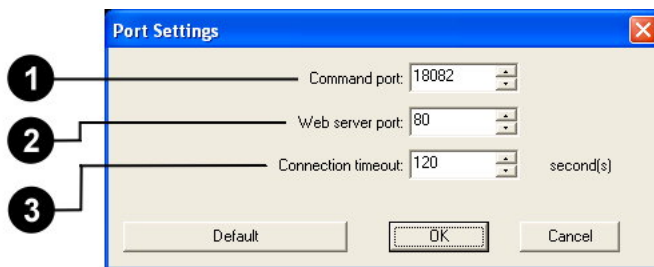

- | | | |
|----------|--------------------|---|
| 1 | Command port | Specify the Command Port of the DVR site server. |
| 2 | Web server port | Specify the Web Server Port of the DVR site server. This should be the same as the TCP port in the Site Server program. |
| 3 | Connection timeout | Specify how long (in seconds) Remote Record Player will wait for a response from the DVR site server before Remote Record Player stops trying to connect. |

It is recommended to use the default values for “Command port” and “Web Server port.” Click the “Default” button to restore the default values in the dialog box.

Downloading video recording from a remote site server

Click the “Download Record” button to open the “Download” dialog box then configure the settings below.

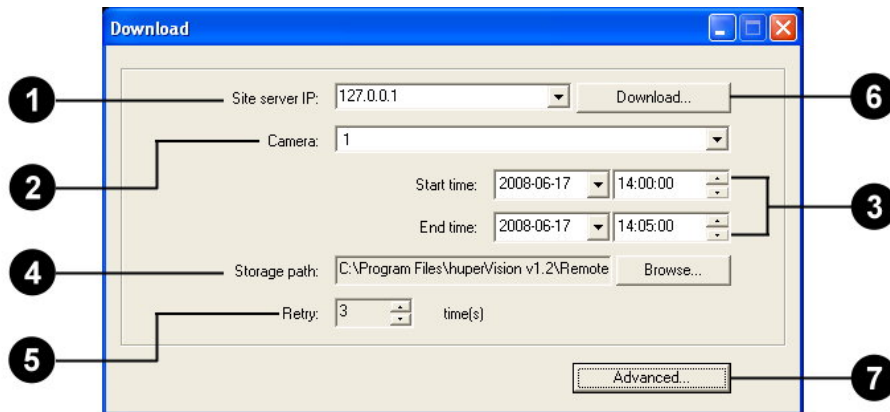

- 1** Site Server Specify the IP address or domain name of the DVR Site Server. Click the drop-down arrow to select from previous Site Servers that were accessed.
- 2** Camera Click to select the camera number in the remote site server from where you want to download video recordings.
- 3** Start/end Time Specify the date and time range of the video recording you want to download from the remote site server. The length of the specified period should be 10 minutes or lower.
- 4** Storage path Click the “Browse” button to specify the folder location where you want to save the downloaded video recording.
- 5** Retry Use the arrow keys to specify how many times to retry downloading the video recording when the initial download try fails.
- 6** Download Click to download video recordings. Opens the “Login” dialog box where you may need to specify a valid user ID and password in order to connect to the remote site server.
- 7** Advanced Click this button to open the “Port Settings” dialog box to configure site server port settings.

Note: The Download button will be disabled when the download duration is larger than 10 minutes.

After clicking the “OK” button (valid User ID and Password may be required before you can click the OK button) in the “Login” dialog box, a dialog box will open showing you details of the video recording that is being downloaded. Click the “Cancel” button if you want to stop the download process.

Playing back downloaded video recordings

Click the “Open Record” button to open the “Open” dialog box and select the downloaded video recording file then click the “OK” button. The video recording file is displayed on the Remote Record Player screen.

Navigation Panel

Use the Navigation Panel to control the playback of recorded video.

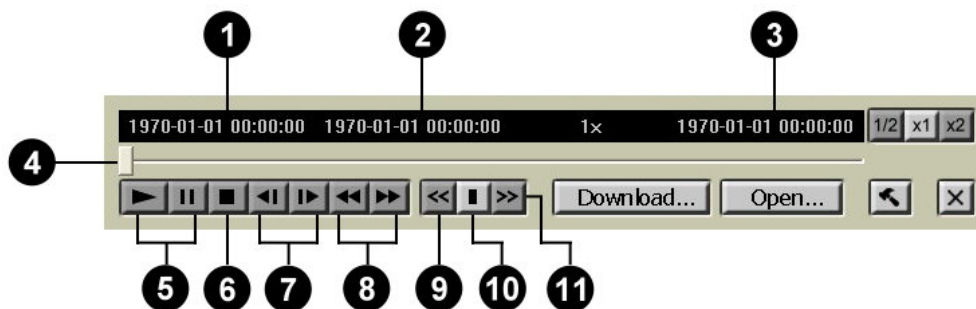

- 1** Start Timecode This shows the start time of the downloaded video recording.
- 2** Current Timecode Shows the timecode of the current video scene.
- 3** End Timecode This shows the end time of the downloaded video recording.
- 4** Navigation Bar Allows you to jump directly to any part of the recorded video. Drag the slider tab to the desired part of the recorded video.
- 5** Play / Pause Plays/Pauses the playback at the current frame.

- | | | |
|-----------|-------------------------|---|
| 6 | Stop | Terminates the playback and moves to the starting frame. |
| 7 | Previous / Next Frame | Moves to the previous/next video frame. |
| 8 | Backward / Forward | Moves back/forward one or more video frames. |
| 9 | Decrease Playback Speed | Slows down video playback. Click once to play the recorded video at half (1/2 x) the normal speed. Click again to play the video at a quarter (1/4 x) of the normal speed. The slowest speed is 1/32 x. |
| 10 | Normal Speed | Plays the recorded event at its original speed. |
| 11 | Increase Playback Speed | Increases the playback speed of the video. Click once to double (2 x) the playback speed. Click again to quadruple (4 x) the playback speed. The maximum speed is 64 x. |

Changing the zoom ratio of the video during playback

When playing downloaded video recordings, you can change the zoom ratio of the video recording by clicking one of the “Zoom Ratio” button. Besides being able to view your video in its actual size, you can choose to view the video recording at 1/2 or 2x the original size.

Chapter 8

huperRemote PDA

huperRemote PDA is a Windows CE based software that allows you to monitor the video cameras from a remote DVR Site Server on a PDA.

The User Interface

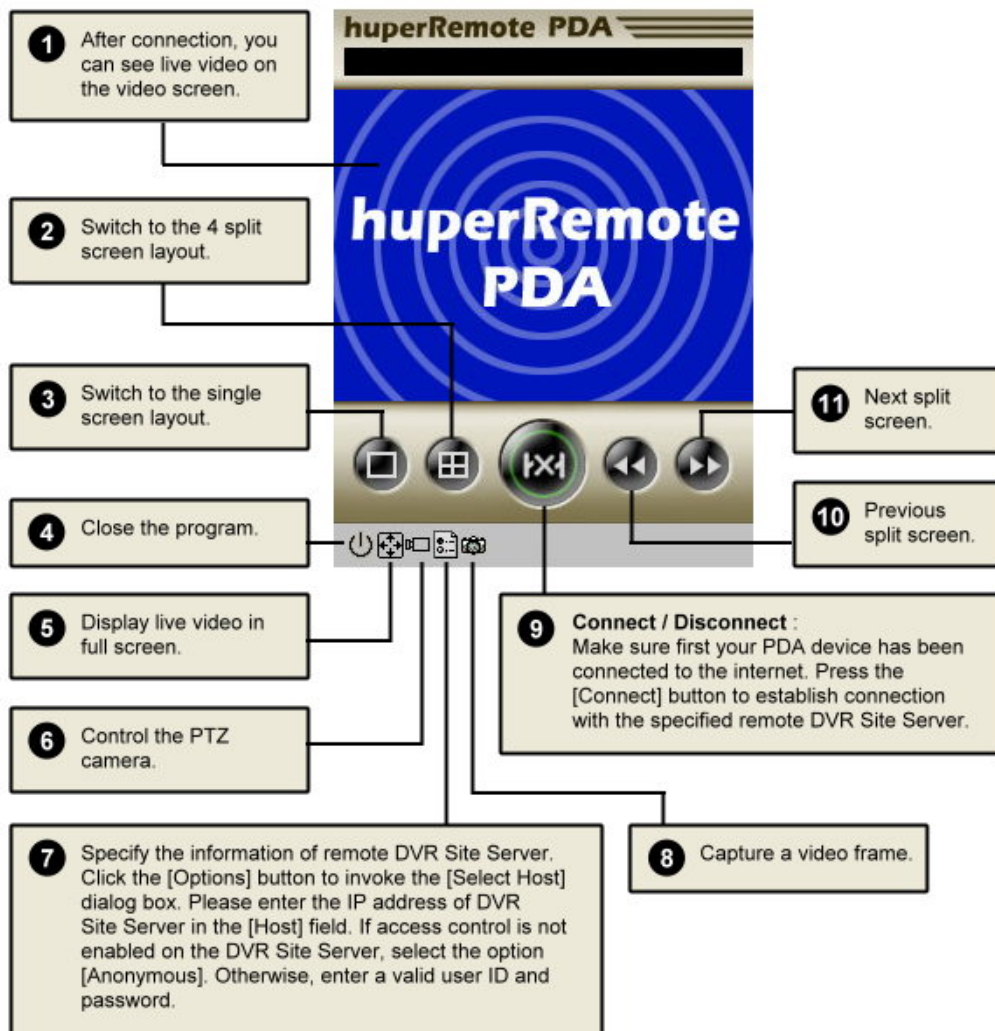

Chapter 9

List Server

List Server is a program that keeps track of the Site Server computers that are connected on the local network and maintains the user account database. After List Server is installed, by default, it automatically runs in the background when the computer where it is installed is started up.

Running the List Server

Before you run the List Server program, first disable the Internet Connection Firewall in Windows. You can disable it through the Control Panel's Network Connections dialog box.

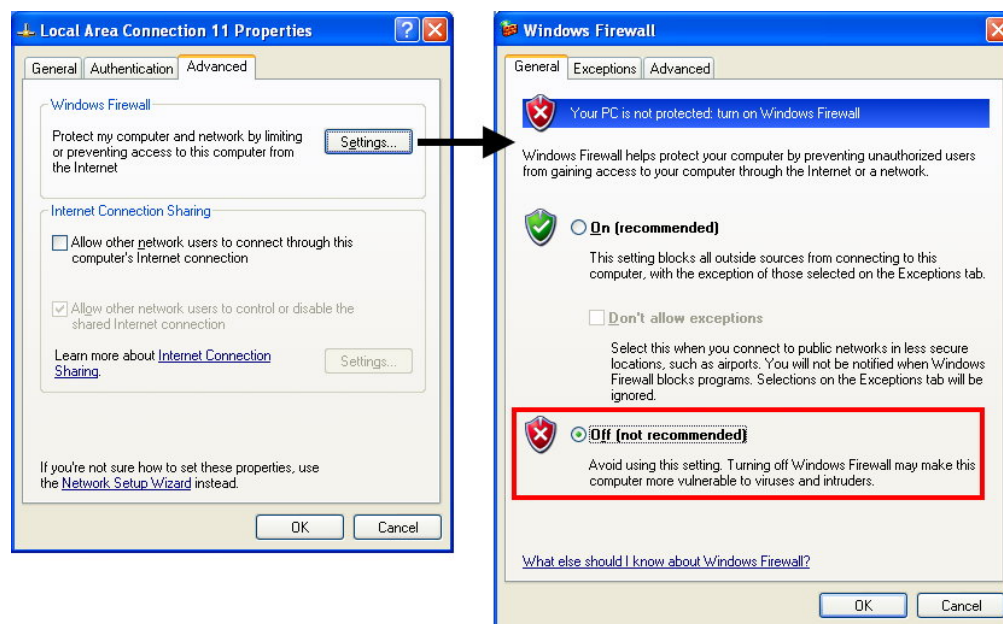

Note: The Internet Connection Firewall feature protects your computer from hackers. If you need to use this feature, refer to Microsoft Windows documentation for information on how to properly set up the firewall.

To run List Server, click Start > Programs > Huper List Server > List Server. List Server will be launched in the background, and its program icon will be added to the right side of the Windows taskbar.

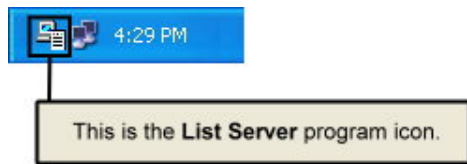

To open the List Server program window and customize its settings, you need to log into the program.

Note: Only the system administrator can log into the List Server and customize its settings.

To log into the List Server:

1. Right-click the List Server icon, then select Log in.
2. You will then be prompted to enter the system administrator name and password.

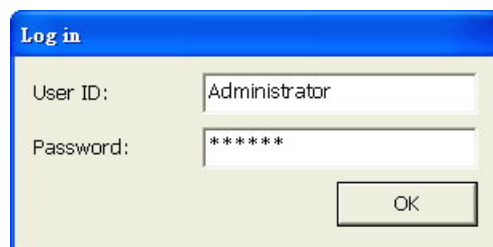

If this is your first time to open the List Server, enter "Administrator" as the name and "system" as the password.

3. Change the administrator password to avoid unauthorized access of the List Server. Click Modify, then enter a secure password.

Customizing List Server settings

The List Server program window has four tabs that provide different sets of settings. After you have modified its settings, you need to restart the List Server program for your new settings to take effect.

Account tab

In the Account tab, the upper part shows the existing users and information about these users, whereas the lower part shows the number of users that are assigned to each type of user group.

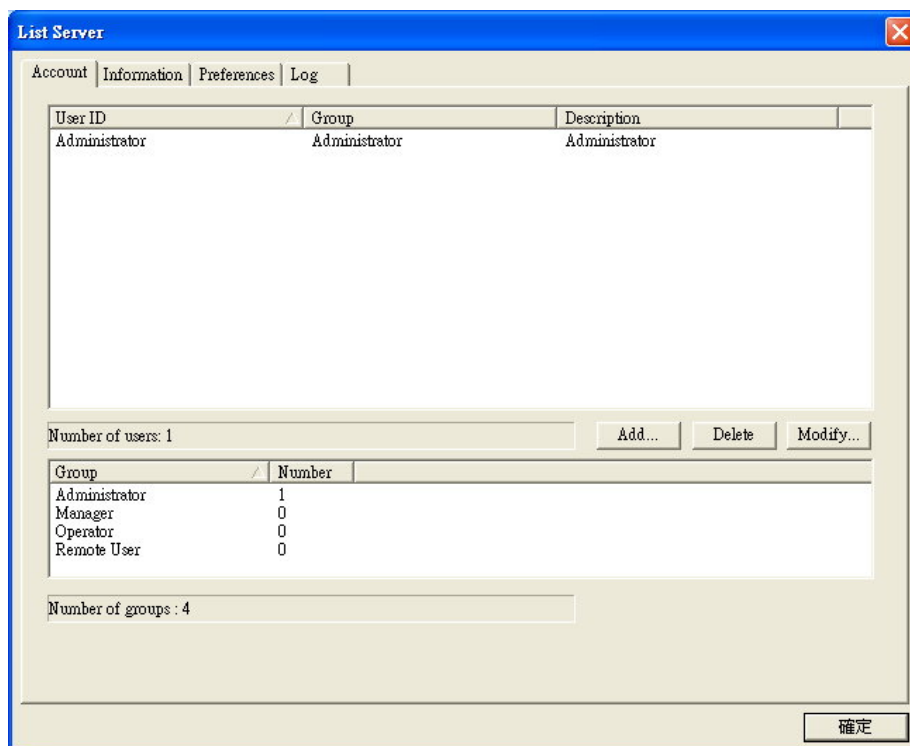

In this tab, you can add, modify or remove user accounts. For each user account, assign it to one of these four types of user groups (i.e., privilege level): Administrator, Manager, Operator, or Remote User.

Information tab

The Information tab keeps track of Site Server computers that are logged onto the List Server. In this tab, you can see the dynamic IP addresses or fixed IP addresses of all the Site Server computers. When you select a computer from the list, the right side of the program window will show information about the associated video cameras such as the camera name, video resolution, operation status (e.g., video recording, detection, etc.).

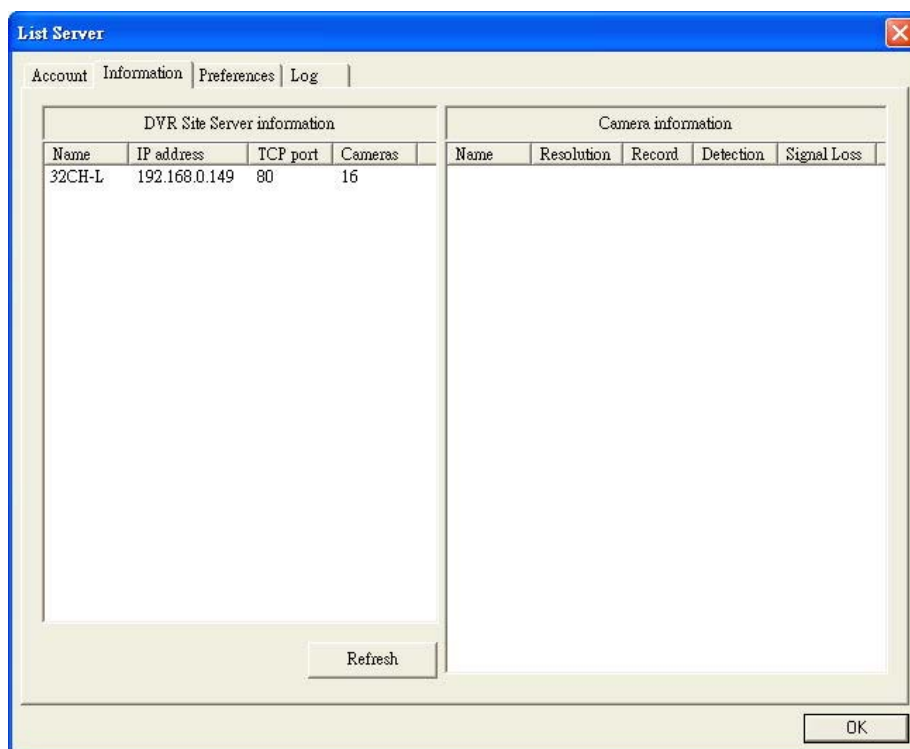

Preference tab

The Preference tab contains network settings for the List Server computer.

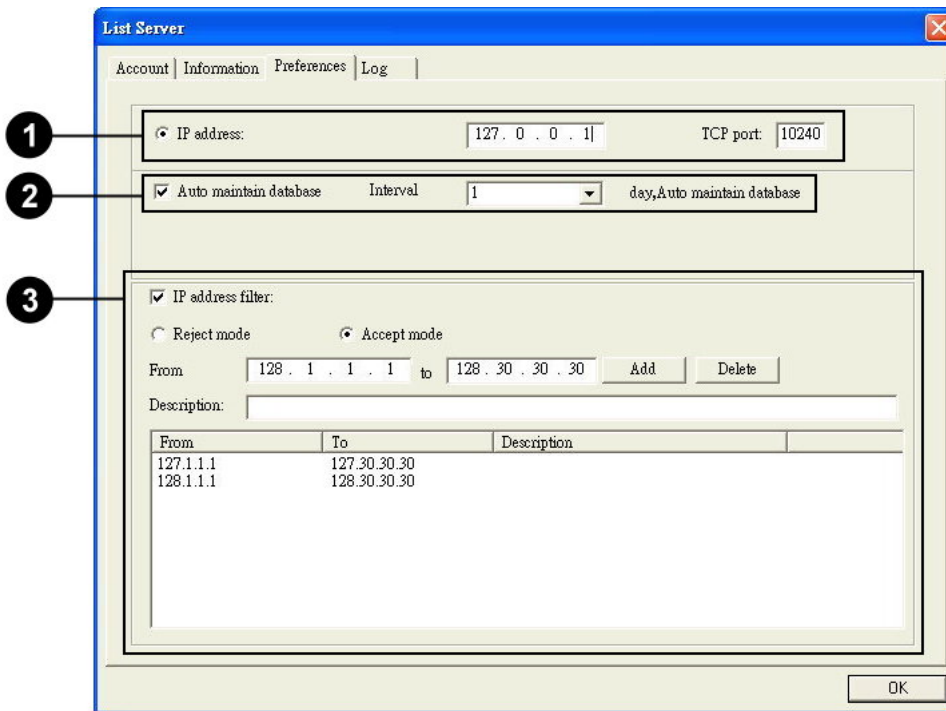

- 1 IP address and TCP port Specify the IP address and TCP port number to be used by the List Server computer. (After modifying the settings, restart the List Server program for the new settings to take effect.)

Note: If List Server is accessed via a NAT, firewall or IP-sharing device, make sure that the List Server computer's TCP port is port-forward to the device's port number.

- 2 Auto maintain database Select this option to enable auto maintenance of the List Server's database. Specify the desired time interval between each maintenance.
- 3 IP address filter Select this option to restrict only a specific range of dynamic IP addresses to log onto and access the List Server. To define a range, enter the start and end IP addresses, then click the Add button. Specify whether this range of address will be ignored or accepted by selecting either the Reject mode or Accept mode option.

Log tab

The Log tab displays operation logs such as List Server's startup and shutdown logs, login and logout times of Site Server computers, and user login and logout times. To control the size of the log file, either specify the maximum allowable number of operations to be logged in the Log limited by field, or specify the number of days to retain operation logs. To view operation logs of a specific date, choose the range of inquiry dates then click Search.

You can back up the operation logs by clicking Backup, or clear the logs by clicking Delete.

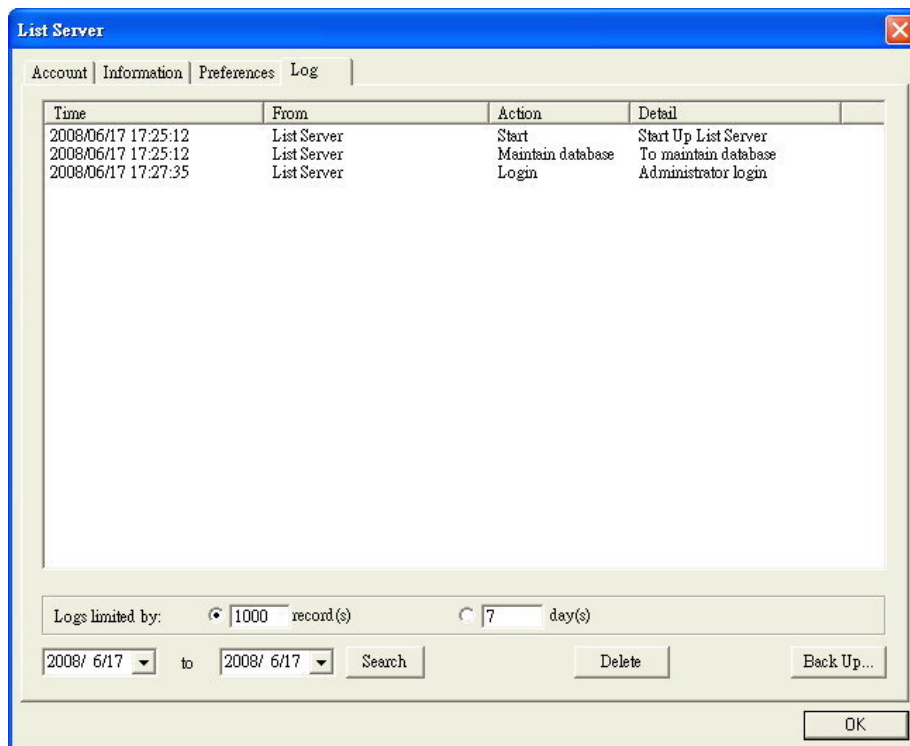

Appendix 1

How to Use the I/O Ports of a Video Capture Card

1. The Specification of I/O Ports

Each video capture card provides four I/O ports. Each I/O port can connect to an Input Device (e.g. Infra-red sensor) or an Output Device (e.g. Alarm). The H1004S video capture card has four I/O ports, each marked by "GPIO1", "GPIO2", "GPIO3" and "GPIO4" (Please refer Figure 1-1 and 1-2). Every I/O port has two pins, a positive pole pin marked with "+" and a negative pole pin marked with "-". For other models of video capture cards (Please refer Figure 1-3 and 1-4), positive pole pins are at the side marked with "GPIO1-GPIO4", negative pole pins are at the opposite side marked with "G". The left-most pin pair are the first I/O port, the following pin pairs are numbered accordingly (second I/O port, third I/O port...). The I/O ports link directly to the BT878 GPIO* ports. Below are their specifications

Digital Input/Output		Min.	Max.
GPIO Input	Input High Voltage	2.0V	5.5V
	Input Low Voltage	-0.5V	0.8V
GPIO Output	Output High Voltage (I=-1.2mA)	2.4V	5V
	Output Low Voltage (I=8mA)	-	0.4V

Note:

Š GPIO: General Purpose Input/Output ports.

Š Detail GPIO specification. Please read the specifications of the Bt878 chip.

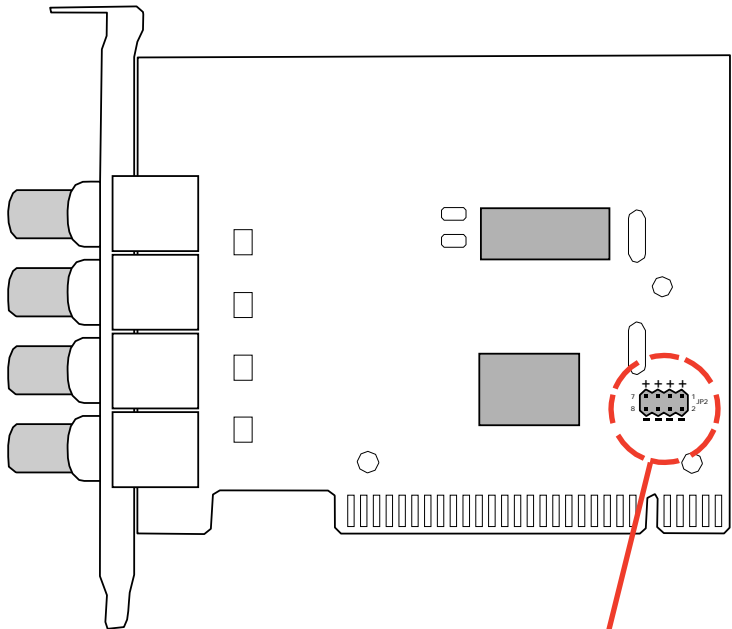

▲ Figure 1-1 H1004S Video Capture Card

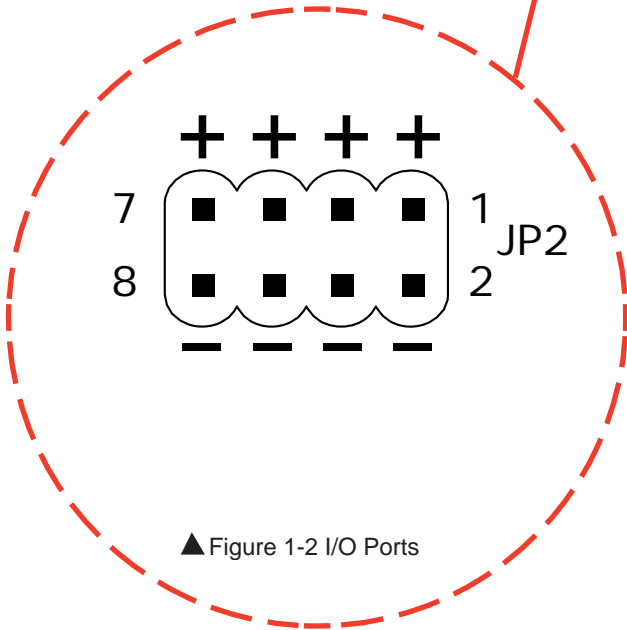

▲ Figure 1-2 I/O Ports

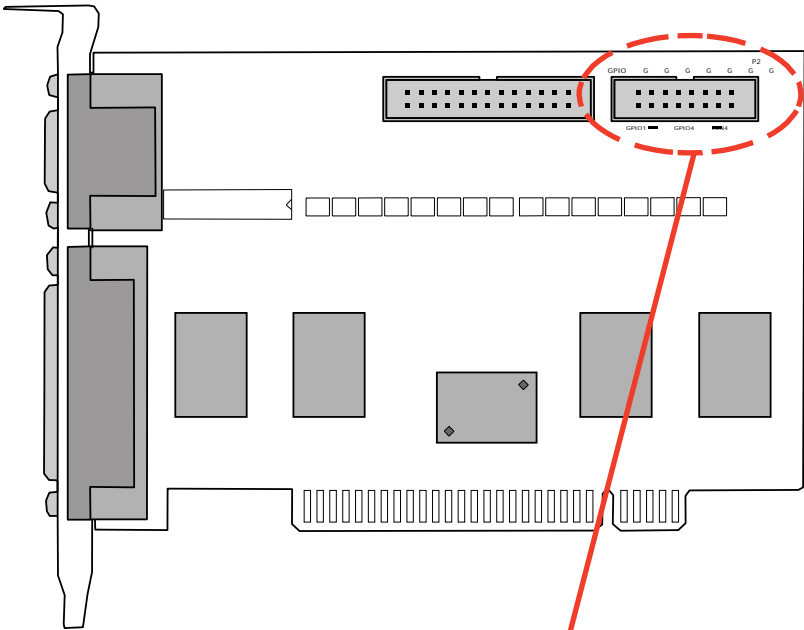

▲ Figure 1-3 H4004Q Video Capture Card

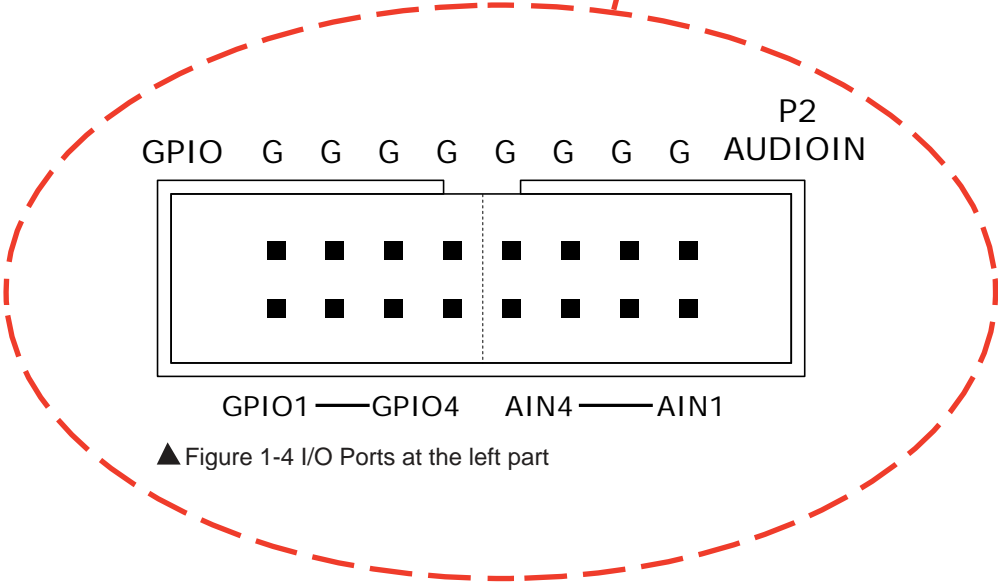

▲ Figure 1-4 I/O Ports at the left part

2. Installing the Cable

You need to install a cable to connect I/O ports to I/O devices. You can purchase a cable from any PC accessory store or use the cable that comes with the video capture card. Please note that some models of video capture cards do not include cables. You can purchase the cable from the dealer where you purchased the product.

3. Connecting to I/O Devices

Each I/O port can connect to an input device or an output device. If the input/output voltage from/to the I/O devices does not match the specifications of I/O ports, the video capture card or output devices may be damaged due to overrunning of the voltage limit. An extra circuit for increasing/decreasing the voltage from the input device or to the I/O port can solve the problem. Please note that I/O ports can only accept DC (Direct Current).

4. Setting I/O Devices

I/O devices and I/O ports should have their corresponding positive pole pins connected and corresponding negative pole pins connected. If the first I/O port is connected to an input device, please select the first option on the "Device/Input" tab of the "Preferences" dialog box then specify the device type (either NC or NO). (Please refer to Figure 4-1.)

If the first I/O port is connected to an output device, please select the first option on the "Device/Output" tab of the "Preferences" dialog box then specify the device type (either NC or NO). (Please refer to Figure 4-2.) If you installed other I/O devices, follow the rule above for the "Preferences dialog box: Device tab".

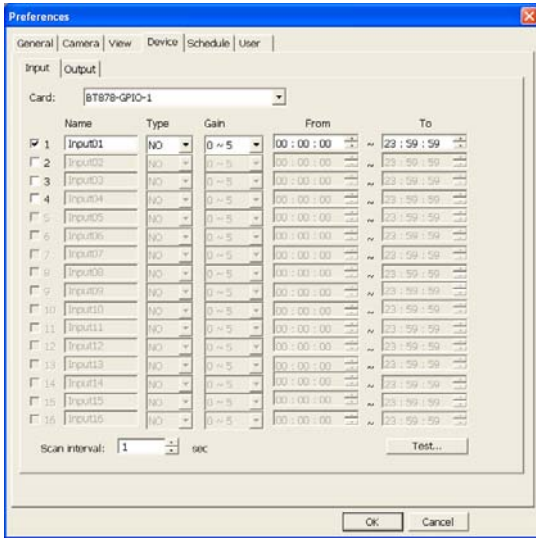

▲ Figure 4-1 Enable the Input

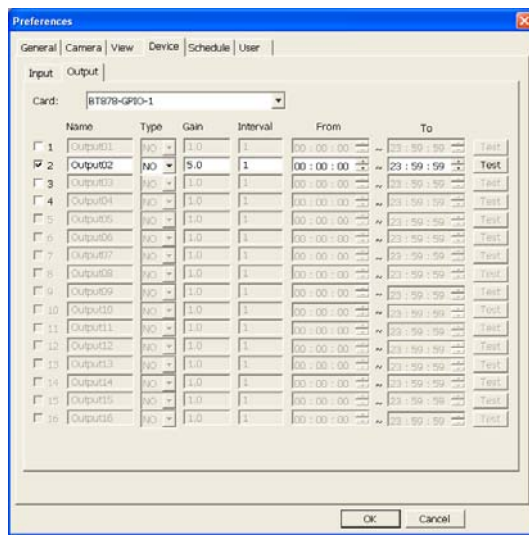

▲ Figure 4-2 Enable the Output

5. Testing the I/O Device

After connecting the I/O ports to I/O devices and finalizing the settings, click the "Test" button on the "Preferences/Device" tab to check the connection and settings. Click the "Test" button on the "Preferences/Device/Input" tab to launch a dialog box displaying the current input voltage of input devices. (Please refer to Figure 5.) You can trigger the input device and track the changes of input voltage in this dialog box. Click the "Test" button on the "Preferences/Device/Output" tab to change the output voltage. You can check the behavior of output devices to make sure the connections and settings are correct.

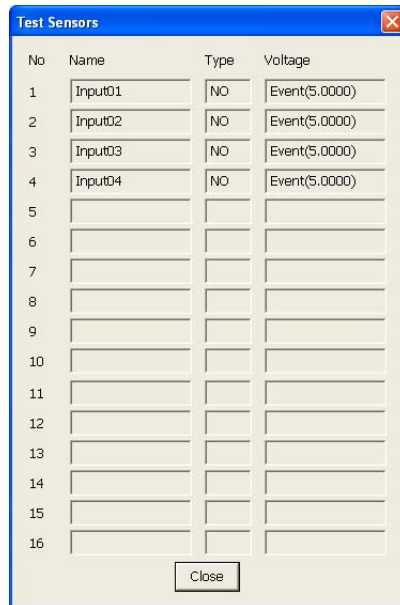

▲ Figure 5 Test Sensors

6. Including I/O Devices to the operation of DVR Site Server

When an input device has been triggered to issue an event, Site Server can have three reactions:

1. In the event recording mode, starts the video recording and Site Server keeps recording till the event ends.
2. In non-event recording mode, the event time segment is recorded to enable searching of video recordings later.
3. Issue event notifications.

In order to include input devices to the normal operation of Site Server, you need to select the "Sensor detection" option in the "Detect events by" group on the "Preferences/ Camera" tab for certain cameras. Then click the "Settings" button behind the option

"Sensor detection" to assign input devices.

Output devices are for event notification. You can select the "External devices" option in the "Respond to events by" group on "Preferences/Camera" tab for certain cameras. Then click the "Settings" button behind the option "External devices" to assign output

Appendix 2

Profile Settings of LiveTag.ini

LiveTag.ini Introduction

What is the profile settings for?

Some settings of huperVision are related to the product models and hardware environments. These settings are put on the “LiveTag.ini” file with default values. Installers and users can modify the settings for customization or performance/quality tuning.

Where is the file for the setting?

The file “LiveTag.ini” is placed at the product installed folder. The default location of the file is at “Drive:\ Program Files\huperLab\huperVision\Bin”, where Drive could be C, D, etc.

How to Modify the Settings?

Prior to the modification, you need to know each setting standing for. Below explain the settings one by one.

[SYSTEM] Section

Key Name	Default	Description
Smart_Saving_interval	1	Specify the recording frame rate while no motion video in No-stop Smart recording mode. 1 for 1fps, 2 for 0.5 fps, etc.
NORESPONSETIME	130	Specify the time out (in seconds) for hardware watchdog to reboot the system if the system has not been responding for a while. The maximum value is 255.
H8008DB	1	Force H8008DB capture card use bracket mode for video sources input.

IVS_FPS	15	The frame rate for intelligent video analysis. Increasing this value gets smoother video for analysis modules and probably better results for some analysis.
LIVEMON	1	Enable software watchdog LiveMon.exe, which monitors the program status of site server.
Time_shift_threshold	3	The maximum allowable time shift (in seconds) for site server to keep using the same file for recording. Site server switches to another file for recording If the system time is significantly changed.
Start_Minimized	0	Start site server in background mode.

[NONCHANGEDISPLAY] Section

Key Name	Default	Description
NOCHANGE	1	Specify if site server should change desktop resolution to 1024x768 16-bit mode before it starts.

[GDI_BG_COLOR] Section

Key Name	Default	Description
MaskGridR	250	Specify the color (R value) of mask patterns for motion detections.
MaskGridG	250	Specify the color (G value) of mask patterns for motion detections.
MaskGridB	250	Specify the color (B value) of mask patterns for motion detections.
Bg_colorR	0	Specify the background color (R value) of mask patterns for motion detections.
Bg_colorG	0	Specify the background color (G value) of mask patterns for motion detections.
Bg_colorB	0	Specify the background color (B value) of mask patterns for motion detections.

[COMPRESSOR_FAST] / [COMPRESSOR_GOOD] / [COMPRESSOR_BEST] Section

Key Name	Description
GOP	Specify the frame rate of I-frame. Larger value gains smaller data size but may reduce the image quality.
QP	Specify the QP value. Smaller value gains better image quality but has larger data size.
Search_level	Specify the motion searching method. Value 1 has best performance with largest data size. Value 2 has good performance with smaller data size. Value 3 is slowest with smallest data size.

PS: Settings for HM compression.

Key Default	FAST	GOOD	BEST
GOP	30	30	30
QP	7	7	5
Search_level	1	2	2

PS: Please DO NOT change these key default values of compression settings or it may increase the CPU consumption.

[H264_FAST] / [H264_COMPACT] / [H264_GOOD] / [H264_BETTER] / [H264_BEST] Section

Key Name	Description
QP	Specify the QP value. Smaller value gains better image quality but has larger data size.
Deblocking	Specify if a deblocking filter should be applied to blocks in decoded video to improve visual quality and reduce data size by smoothing the block edges. Turning on deblocking will increase the CPU usage.

CABAC	Choose between context-adaptive binary arithmetic coding (CABAC) and context-adaptive variable-length coding (CAVLC). CABAC=1 will reduce data size but increase the CPU usage considerably.
Partition_16x16	Specify if H.264 encoder should predict block with size of 16x16 , 16x8 and 8x16. Turning on this option might reduce data size with some additional CPU usage.
Partition_8x8	Specify if H.264 encoder should predict block with size of 8x8 , 8x4, 4x8 and 4x4. Turning on this option might reduce data size with some additional CPU usage.
GOP_MIN	Specify the minimum frame interval of I-frame. Larger value gains smaller data size but may reduce the image quality.
GOP_MAX	Specify the maximum frame interval of I-frame. Larger value gains smaller data size but may reduce the image quality.
Search_level	Specify the motion searching method. Larger value might reduce data size with larger CPU cost.
Search_range	Specify the motion searching range. Larger value might reduce data size with larger CPU cost.
Subpel_level	Specify the subpel motion searching level. Larger value might reduce data size with larger CPU cost.
Chroma_ME	Turning on Chroma_ME to perform motion searching for chroma components of video, which might reduce data size with larger CPU cost.

PS: Settings for H264 compression.

Key Default	FAST	COMPACT	GOOD	BETTER	BEST
QP	30	29	26	23	20
Deblocking	0	1	0	0	0
CABAC	0	1	0	0	0
Partition_16x16	0	1	0	0	0
Partition_8x8	0	1	0	0	0
GOP_MIN	30	30	30	30	30
GOP_MAX	30	60	30	30	30
Search_level	0	1	1	1	1

Search_range	0	16	16	16	16
Subpel_level	0	1	1	1	1
Chroma_ME	0	1	1	1	1

PS: Please DO NOT change these key default values of compression settings or it may increase the CPU consumption.

[AUDIO_FORMAT] Section

Key Name	Default	Description
SAMPLE	8000	Specify the audio sampling rate. 8KHz by default.
BIT	8	Specify the sample resolution, 8 bits by default. It could be 8 bits or 16 bits.

[DRAW_FRAME] Section

Key Name	Default	Description
SmartGenerateJPEG	1	If mobile phone remote watching (JPEG) is enabled, JPEG files will be generated periodically (specified in the preference settings). Turning on SmartGenerateJPEG will stop JPEG generation if there is no web connection after 1 minute (to reduce system resource and CPU usage).

[PTZ_CAMERA_TO_PRESET] Section

Key Name	Default	Description
MinEventDwellTime	2	If "PTZ camera to preset" event notification is used, this option specify the minimum time interval for PTZ camera to dwell in preset position. Note that some events have very short duration.

[CAP_RECOVER] Section

Key Name	Default	Description
ShowMsg	0	Show a count-down message if the capture chips stop responding.
CountDownSec	30	The time-out (in seconds) for the message.
Reboot	1	Reboot the system if the capture chip stop responding.

[DRAW_FRAME_SIZE] Section

The contents in this section are the list of image size for mobile phone remote watching. This setting is located in the Network tab of Preferences dialog.

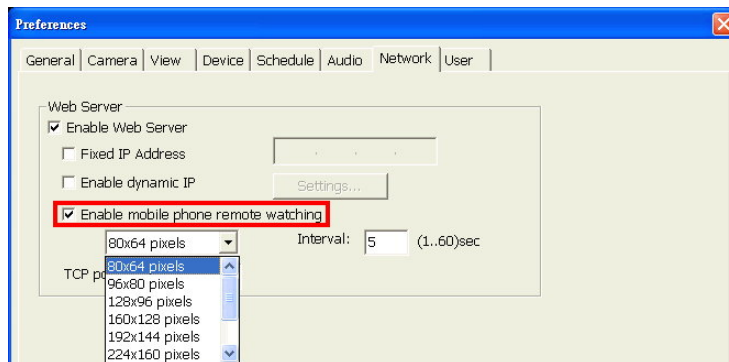

Key Name	Description
XImageSize_(n-1)	The nth menu item of available image width of JPEG for mobile phone remote watching.
YImageSize_(n-1)	The nth menu item of available image height of JPEG for mobile phone remote watching.

[FTP_FRAME_SIZE_NTSC] / [FTP_FRAME_SIZE_PAL] Section

The contents in this section are the list of image size for FTPevent. This setting is located in the Respond to events by section within Camera tab of Preferences dialog.

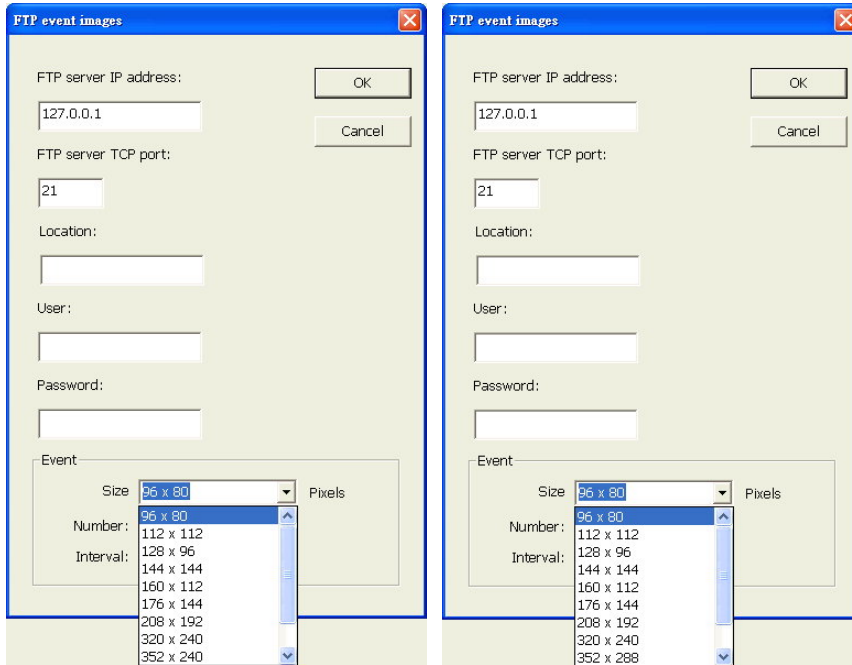
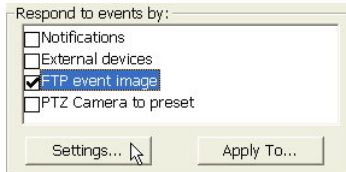

Key Name	Description
XImageSize_(n-1)	The nth menu item of available image width of JPEG for FTP of event notification.
YImageSize_(n-1)	The nth menu item of available image height of JPEG for FTP of event notification.

[EMAIL_FRAME_SIZE_NTSC] / [EMAIL_FRAME_SIZE_PAL] Section

The contents in this section are the list of image size for email notification. This setting is located in the Respond to events by section within Camera tab of Preferences dialog.

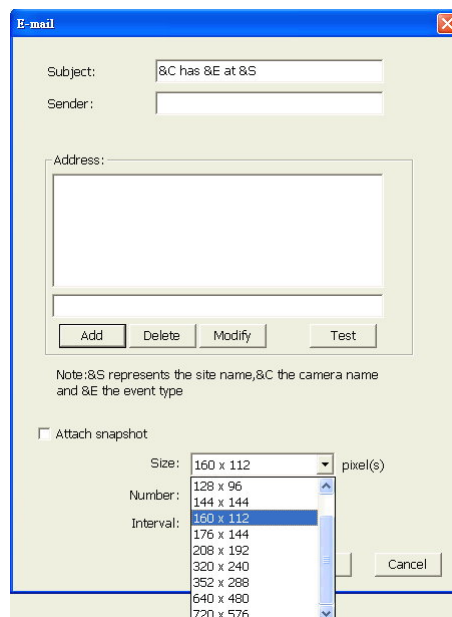
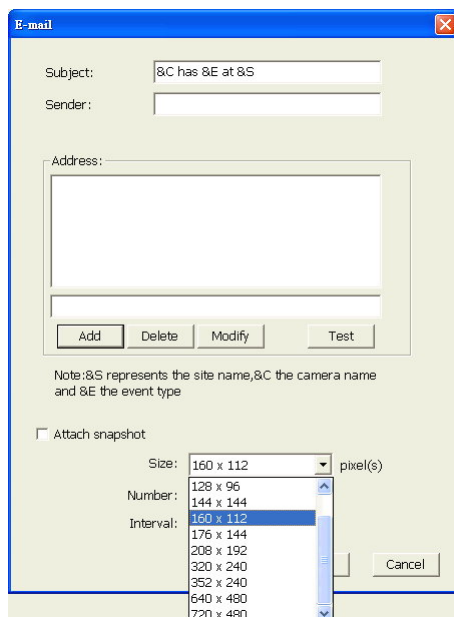
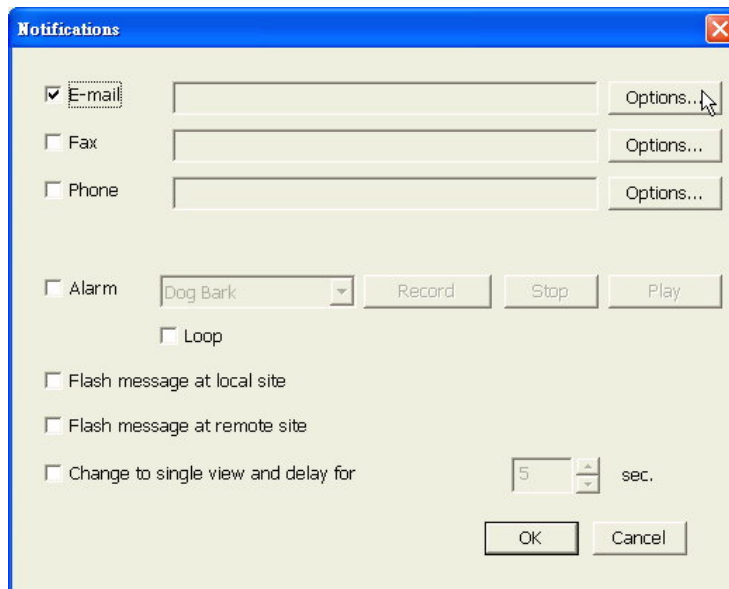

Key Name	Description
XImageSize_(n-1)	The nth menu item of available image width of JPEG for email notification.
YImageSize_(n-1)	The nth menu item of available image height of JPEG for email notification.

[REC_FRAME_RATE_NTSC] / [REC_FRAME_RATE_PAL] Section

The contents in this section are the list of frame rate for recording. This setting is located in the Recording section within Camera tab of Preferences dialog.

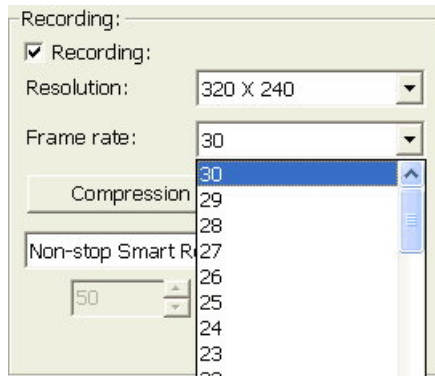

Key Name	Description
U_SERIES_0	Recording frame rate for U-series card (currently unavailable).
RATE_(N-1)	The nth menu item for available recording rate.

[IP_CAMERA] Section

Key Name	Default	Description
TransCode	0	TransCode=0 keeps the original incoming video format of IP camera. TransCode = 1 will transcode the incoming video, which requires more CPU usage
BONUS_IP_CAMERA	0	If the system does not have IP camera license, turning on this option will switch the last camera into IP camera mode.

[AUTO_WINDOWS_LOGIN] Section

Key Name	Default	Description
Enable	1	<p>Enable=1 keeps the option Auto Windows Login in the Preferences General page available and adjustable.</p> <p>Enable=0 will hide the option Auto Windows Login from the dialog and disable auto login feature.</p>

[FlexChannelManager] Section

Key Name	Default	Description
AutoDetectChannel	0	<p>Automatically detect channel number for FlexChannel cards from the number of connectors of video cable.</p> <p>0: Disable, 1: Enable</p>
DefaultChannel	0	<p>Default channel number of FlexChannel card when AutoDetectChannel is disabled.</p> <p>0: Max (16 currently), 4: 4 channels, 8: 8 channels, 16: 16 channels</p>

Appendix 3

Guide to Connect PTZ Camera

I. Something you should know first

1. There are two types of RS-232 ports on a computer: serial ports and parallel ports. The serial port, so-called COM port, is the one for plugging in the control cable from the PTZ camera.
2. PTZ cameras have a RS-422/485 port to connect the control cable. In order to connect a control cable from a PTZ camera to a computer, a converter device from RS-422/485 to RS-232 is usually adopted.

- Note: The connection length of RS232 cable is limited in 15 meters. The connection length of RS-422/485 cable can be up to 1,200 meters.

3. A serial port on a computer can control multiple PTZ cameras. These PTZ cameras connected to the same computer serial port are each identified by a unique hardware ID. You can assign an ID to a PTZ camera by adjusting the ID switch of PTZ camera device. For details, please refers to the PTZ camera manual.

4. RS-232 pin definition

Pin No	Function	
1	CD	
2	RXD	Receive Data
3	TXD	Transport Data
4	DTR	DTE Ready
5	GND	DTE Ready
6	DSR	DCE Ready
7	RTS	Request to Send
8	CTS	Clear to Send
9	RI	Ring Indicator

When we look in front of the female D connector of COM port, the pin on the top right is pin 1. There are numbers beside the pins at the D female connector. The computer communicates with PTZ cameras via pin 2 and pin 3. The lines of pin 2 (RXD) and pin 3 (TXD) each connect to the "Data-" pin and "Data+" pin of the PTZ camera device. Please refer to the PTZ camera manual for the actual pin name.

5. RJ11 cable

RJ11 cable is a general telephone cable. Telephone cable has three types: telephone cable that has 2 lines, 4 lines or 6 lines inside. Be sure to use a telephone cable that has 4 lines or 6 lines inside to connect from PTZ camera to the converter device. When we look in front of the RJ11 connector, the left line is line 1 and the right line is line 6. In the cable, line 4 and line 5 are used for RX+ and RX- lines.

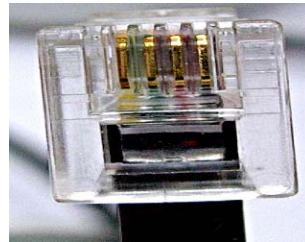

▲ Picture 1: RJ11 connector (four lines inside)

II. Connect the PTZ camera: Use DynaColor dome camera as an example

Step 1: Adjust jumpers at the PTZ camera base.

Jumper	
Dome ID	001
Duplex/Simplex	
S2 & S1	DynaColor protocol

Note:

1. After the PTZ camera has been set up and the pan, tilt and zoom controls seem not very well. You can switch from duplex mode to simplex mode and try again.
2. If there are two more PTZ cameras connect to a serial port at the computer, you must assign each PTZ camera a unique ID.



▲ Picture 2: Jumpers at the bottom side of PZT camera base

Step 2: Connect cable from PTZ camera base to PTZ dome camera.

Connect a cable (comes in the camera pack) from the white connector (at the upper-left corner in Picture 3) of PTZ camera base to PTZ dome camera.

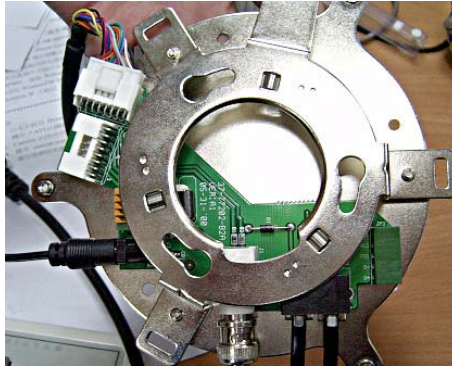

▲ Picture 3: Connectors at the front side of PTZ camera

Step 3: Connect RJ11 cable from PTZ camera base to the RS-422/485 port of converter device. There are two RJ11 connectors at the camera base (at the right-bottom corner in Picture 3). Connect an RJ11 cable from one RJ11 connector at the PTZ camera base to the RS-422/485 port of converter device. Be sure that the RX+ and RX- lines of RJ11 cable each connects to the DATA+ and DATA- pins of converter device.

Note:

1. Another RJ11 connector is optional for connecting to control panel device. These two RJ11 connectors are forks from the same cable.
2. The converter device needs a power supply to perform action. Please refer to the device manual for the voltage level.

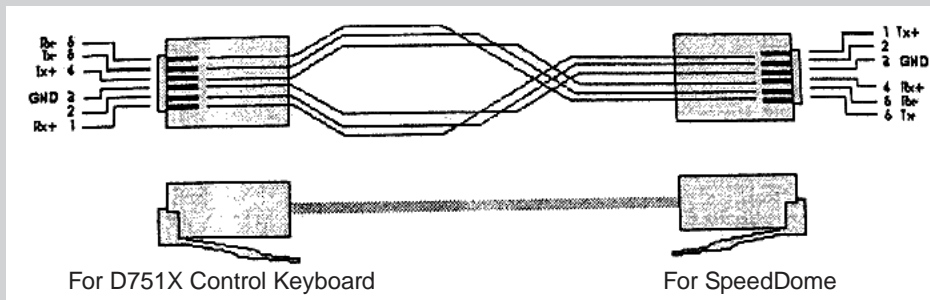



Step 4: Connect RS232 cable from the RS-232 port of converter device to the computer.

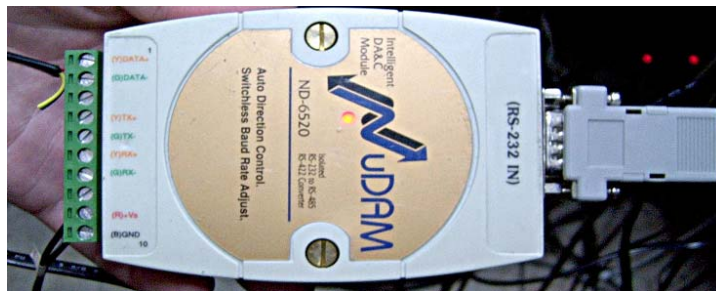

Appendix 4

An Example of PTZ Custom Command Usage:

Enable OSD (On Screen Display) of DynaColor Dome Camera

DynaColor dome camera supports the OSD (On Screen Display) commands for device setting. Below is an example to use the Custom Command page of the Advance PTZ Control Panel to operate the OSD commands of DynaColor dome camera.

Step 1: Click the **PTZ** icon on the Camera Control Panel of the DVR server to display the Advance PTZ Control Panel.

Step 2: Click the  button on the Advance PTZ Control Panel to display the "Settings" dialog box. Click the "Custom" tab to go to the "Custom" setting page.

Step 3: Select check boxes, enter command names and command codes as what shows in the below picture.

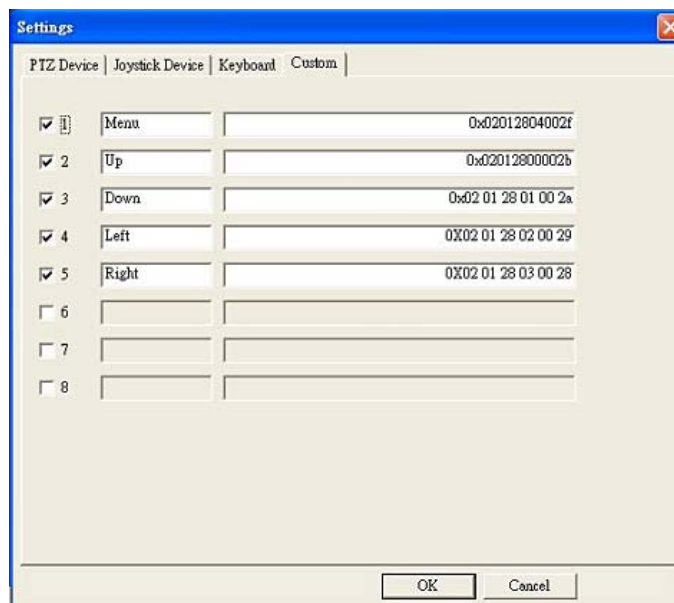

Step 4: Click the mode button on the Advance PTZ Control Panel and select the “Custom” mode. The Advance PTZ Control Panel switches to the “Custom” panel.

Step 5: Click the “Menu” button to display the OSD commands. Click “Up” and “Down” button to navigate menu commands. Click “Left” and “Right” buttons to change the setting.



huperVision is a trademark of Huper Laboratories, Co., Ltd.

Microsoft Windows is a trademark of U.S.A. Microsoft Corporation.

All other trademarks or registered trademarks are the property of their respective holders.

Appendix 5

IOC-0404P Card Guide (H3001)

Introduction

The IOC-0404P is a 4-ch digital input and 4-ch. relay output module. IOC-0404P supports two interfaces with host controller, general-purpose input/output interface and RS232 interface to meet different requirements from the host controller.

IOC-0404P is a digital input module built with 5000VDC optical isolation, and it is suitable for noise environment or floating potential. Also, the 4 isolated inputs provide the best method to prevent the ground loop problem. The IOC-0404P supports dry contact wiring for simple implementation. Moreover, users can read the current input status from the green LED indicators on-board. Each input channel is jumper selectable to either isolated or non-isolated input.

The IOC-0404P provides four channels with Form C relay. IOC-0404P is excellent for ON/ OFF control or low-power switching applications.

For easy monitoring, each relay is equipped with one yellow LED to reflect its ON/OFF status.

Technical Specifications

Digital input:

- Channel : 4-channel/ digital inputs
- Optical Isolation : 5000 Vrms
- Optical-isolator response time : 18 us
- Over-voltage Protect : 70 VDC
- LED Indicator: On: Active; Off : Non-active

- Input Voltage :
 - Dry Contact Logic level 0 : Close to GND Logic level 1 : Open
 - Optical Isolation : 24VDC (Normal)
 - Dry Contact & Optical Isolation Selectable
- Power consumption : 200 mW each channel

Relay output:

- Channel : 4-channel/ relay output with Form C
- LED Indicator : On: Non-active; Off: Active
- Contact Rating :
 - AC 125 V @ 0.6 A; 250 V @ 0.3 A DC 30 V @ 1 A;

Application Wiring

The following are examples on how to connect the cable to your IOC-0404P modules

Input wiring

Diagram

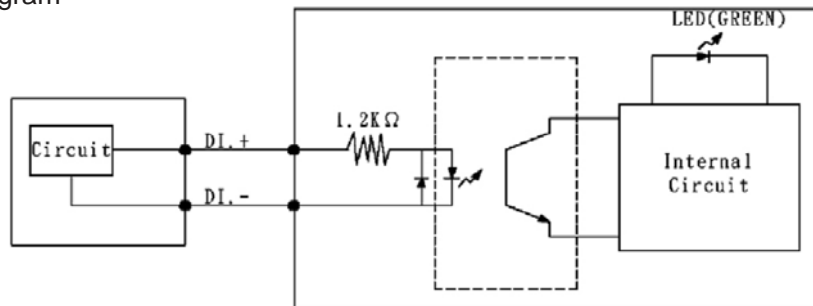

Dry Contact Input

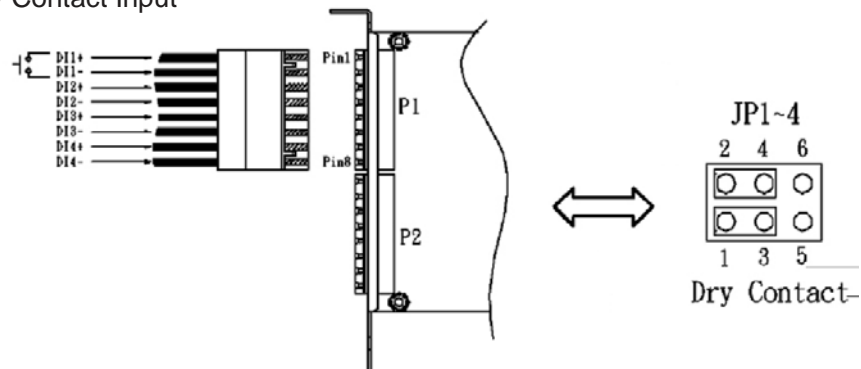

Isolation Digital Input

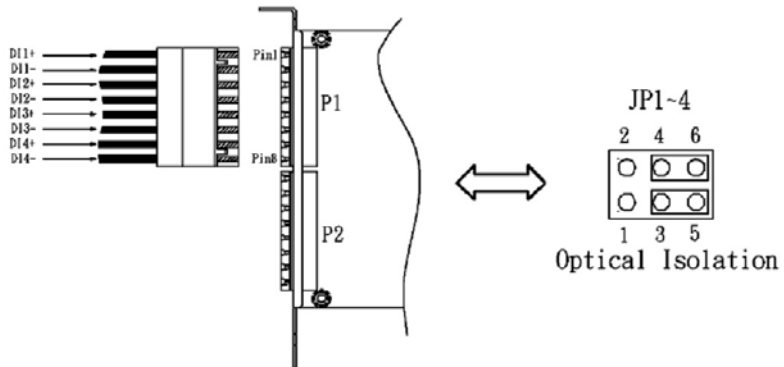

Output wiring

Diagram

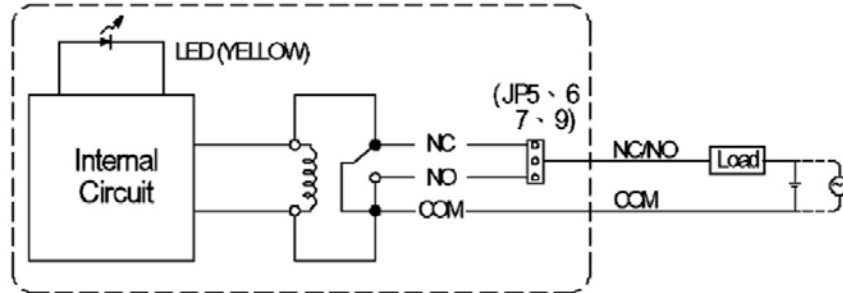

NC (Normal Close) setting

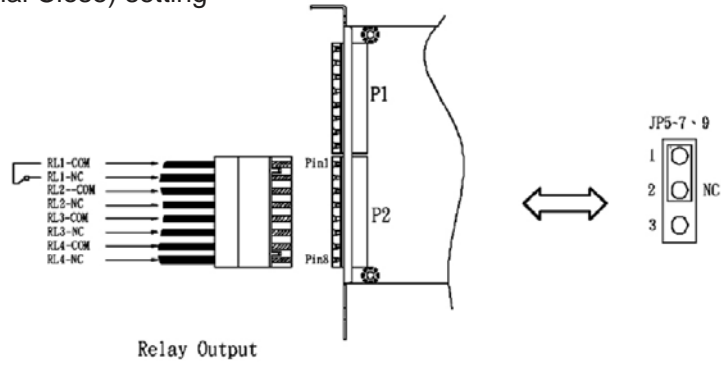

NO (Normal Open) setting

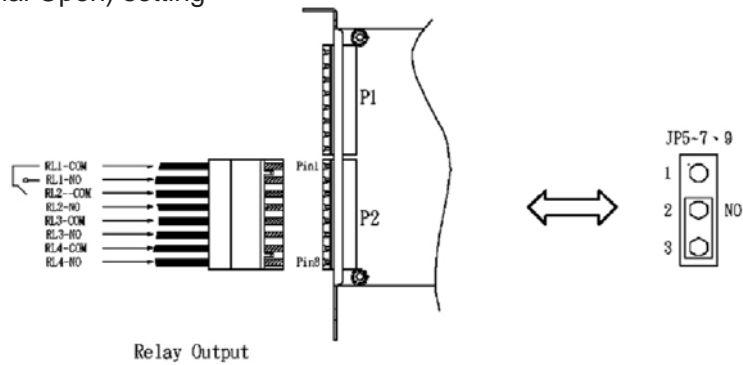

Installation

1. Before installing the IOC-0404P into the system, remove the terminator housing from the IOC-0404P as illustrated in Figure 1.
2. Secure the IOC-0404P using a screw.
3. Connect the input/output cable to the terminator block as desired.
4. Plug the terminal block into the IOC-0404P as illustrated in Figure 2.
5. Check whether the INPUT/ OUTPUT module is fitted in the right terminal and right position.



▲ Figure 1



▲ Figure 2

Host wiring

1. IOC-0404P to 4404S+: Take note that the red line of the cable should connect to Pin2 on the IOC-0404P card and the 4404S+ card.

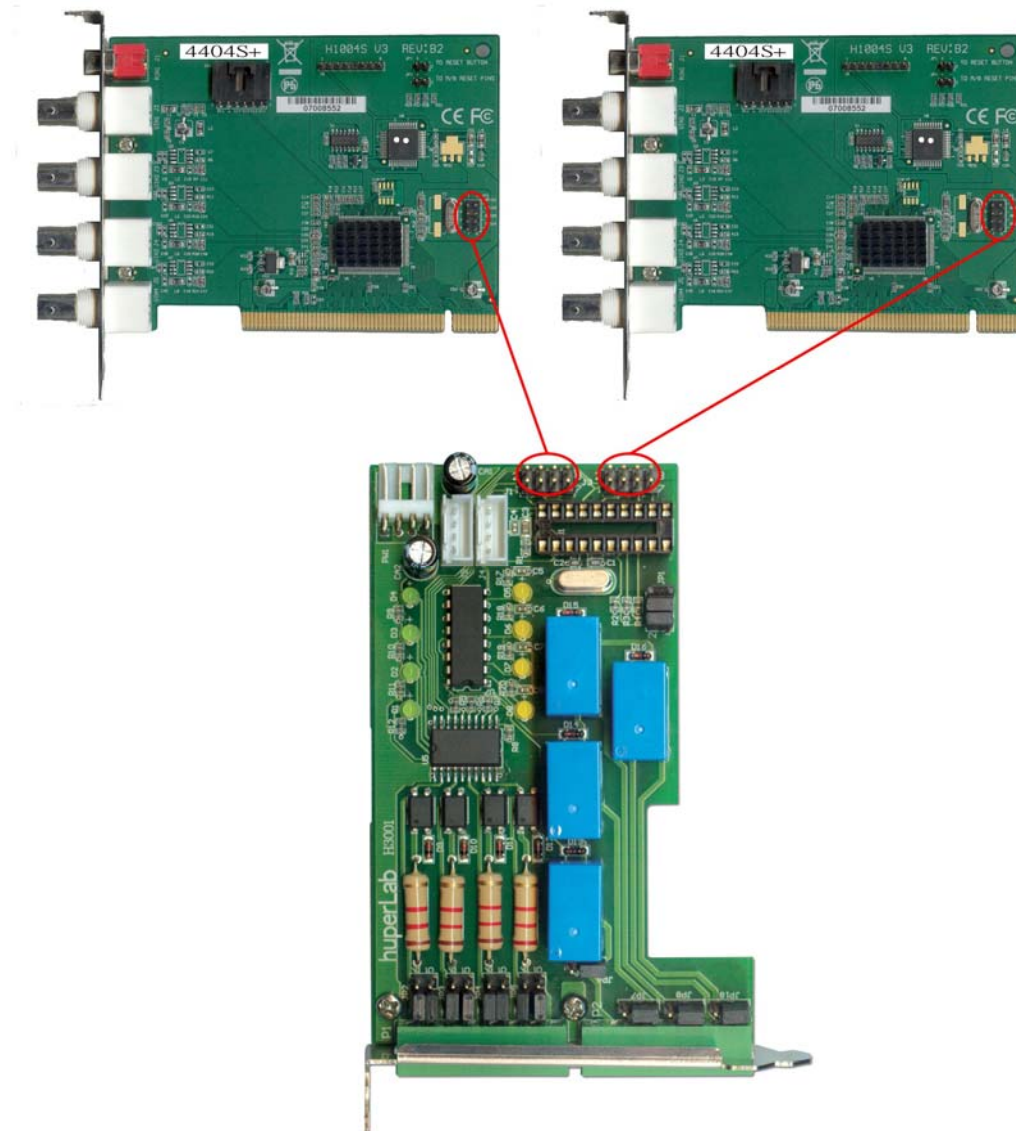

- IOC-0404P to 4416SL: Take note that the red line of the cable should connect to Pin2 on the IOC-0404P card and to the "G" pin on the 4416SL card.
(The same wiring for 4416SB, 4408DB, 4416SG and 4408DG)

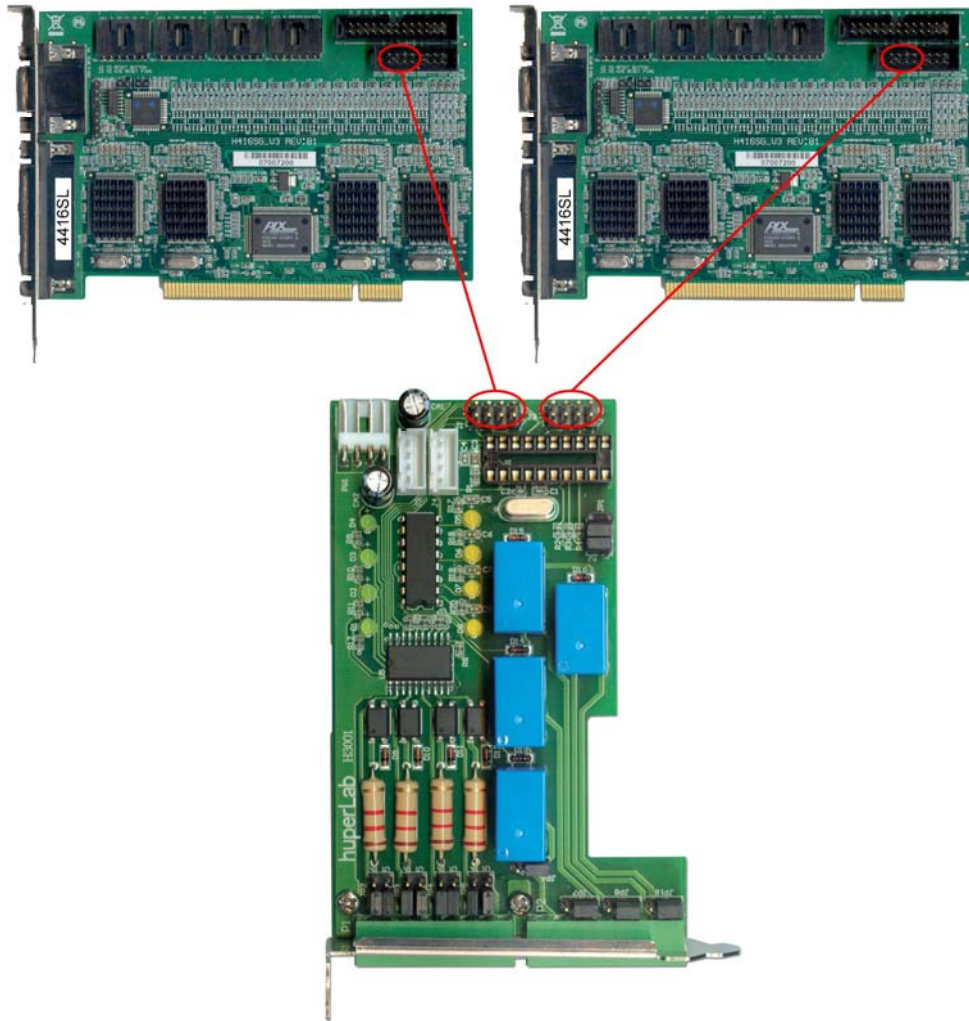

- IOC-0404P to 4416S+-PCIe: Take note that the red line of the cable should connect to Pin2 on the IOC-0404P card and to the "G" pin on the 4416S+-PCIe card.

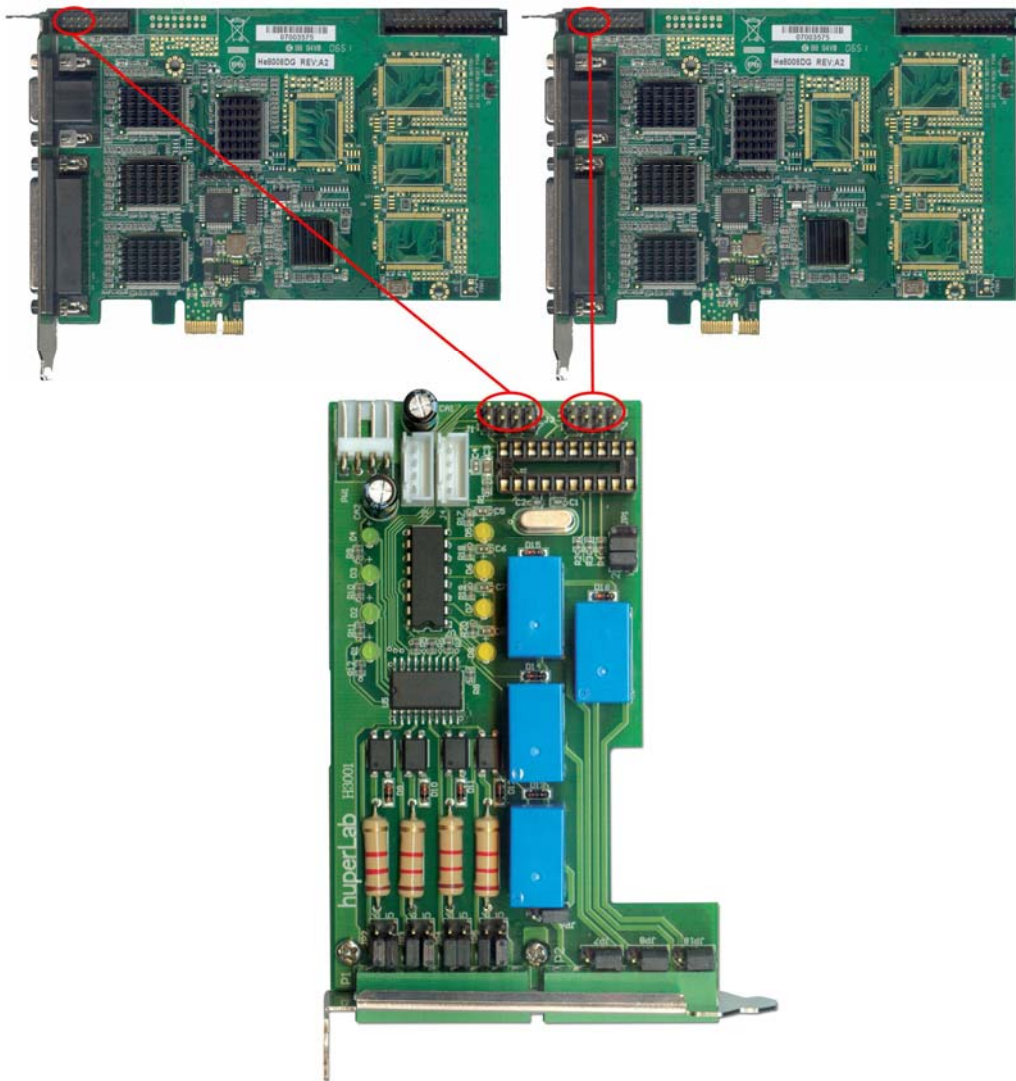

4. IOC-0404P to 4408Q-PCle: Take note that the red line of the cable should connect to Pin2 of the IOC-0404P card and to the "G" pin on the 4408Q-PCle card.

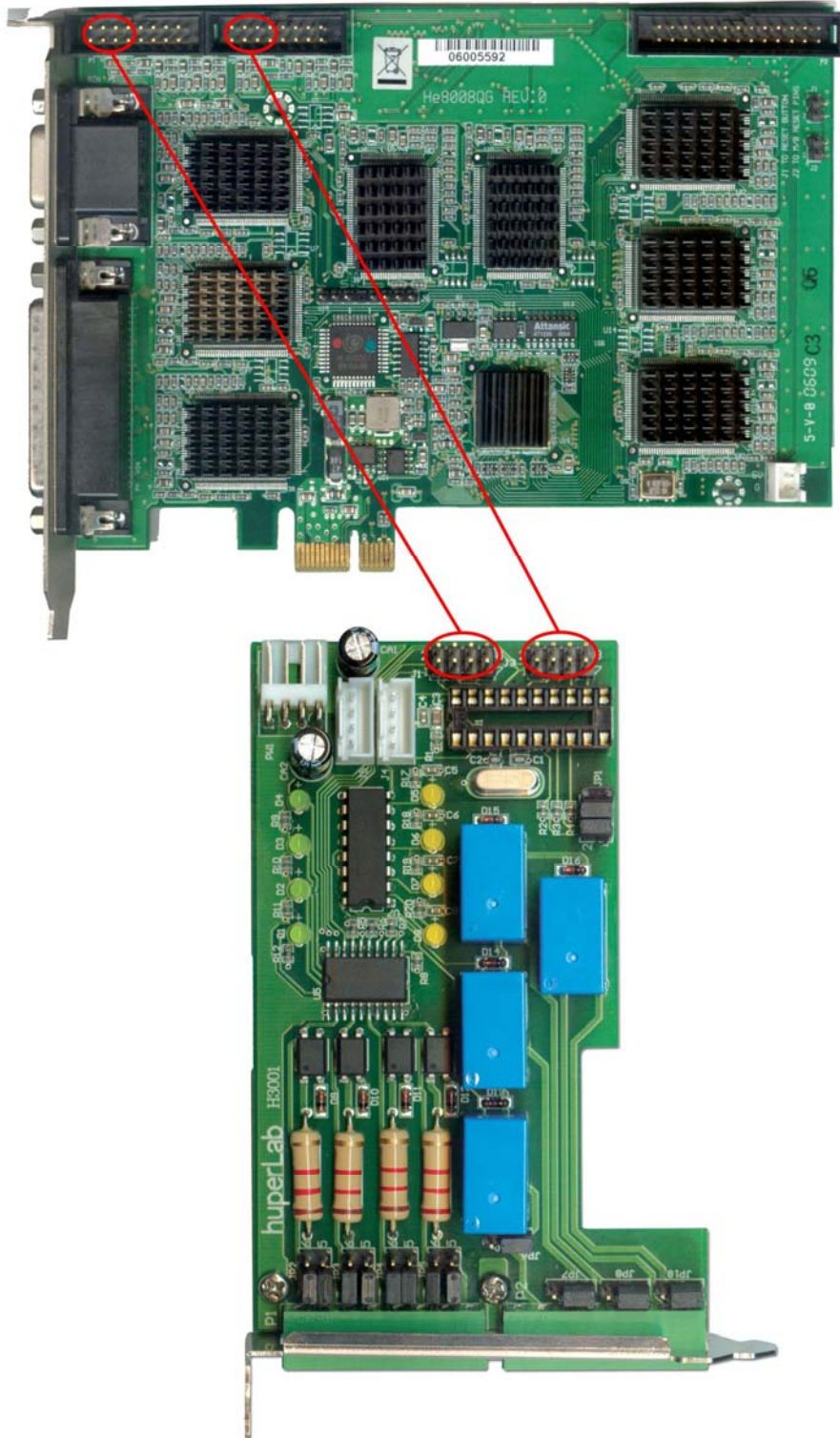

Pin Assignment

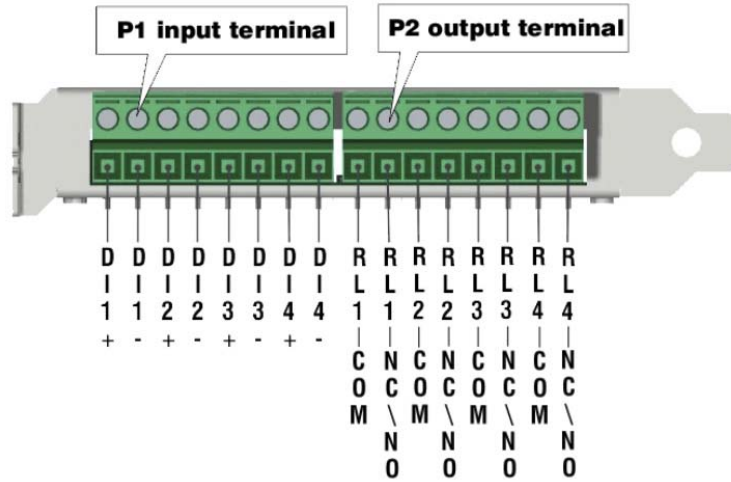

Pin no.	P1 General purpose input	Description
1	DI1+	Input channel 1 +
2	DI1-	Input channel 1 -
3	DI2+	Input channel 2 +
4	DI2-	Input channel 2 -
5	DI3+	Input channel 3 +
6	DI3-	Input channel 3 -
7	DI4+	Input channel 4 +
8	DI4-	Input channel 4 -

Pin no.	P2 Relay output	Description
1	RL1-COM	Relay output channel 1- common
2	RL1-NC/NO	Relay output channel 1- NC or NO
3	RL2-COM	Relay output channel 2- common
4	RL2-NC/NO	Relay output channel 2- NC or NO
5	RL3-COM	Relay output channel 3- common
6	RL3-NC/NO	Relay output channel 3- NC or NO
7	RL4-COM	Relay output channel 4- common
8	RL4-NC/NO	Relay output channel 4- NC or NO

Jumper & connector

Input module dry contact / optical isolation select (JP1 ~ 4)

Channels	Dry contact	Optical isolation
Channel 1 (JP1)	1-3,2-4	3-5,4-6
Channel 2 (JP2)	1-3,2-4	3-5,4-6
Channel 3 (JP3)	1-3,2-4	3-5,4-6
Channel 4 (JP4)	1-3,2-4	3-5,4-6

Relay output NC / NO select (JP5 ~7, 9)

Channels	Normal close (NC)	Normal open (NO)
Channel 1 (JP5)	1-2	2-3
Channel 2 (JP6)	1-2	2-3
Channel 3 (JP7)	1-2	2-3
Channel 4 (JP9)	1-2	2-3

ID selector (JP8)

Card ID	JP8
Card ID 0	1-2,3-4,5-6
Card ID 1	3-4,5-6
Card ID 2	1-2,5-6
Card ID 3	5-6
Card ID 4	1-2,3-4
Card ID 5	3-4
Card ID 6	1-2
Card ID 7	Open

Host interface-RS232 (J1)

Signals	J1
Transmission data (TXD)	1
Ground	2,3
Receive data (RXD)	4

Interface to next IOC-0404P-RS232 (J2)

Signals	J2
Transmission data (TXD)	1
Ground	2,3
Receive data (RXD)	4

Host interface-GPIO (J3)

Signals	J3
Input channel 1-data	1
Input channel 1-ground	2
Input channel 2-data	3
Input channel 2-ground	4
Output channel 1-data	5
Output channel 1-ground	6
Output channel 2-data	7
Output channel 2-ground	8

Host interface-GPIO (J4)

Signals	J4
Input channel 3-data	1
Input channel 3-ground	2
Input channel 4-data	3
Input channel 4-ground	4
Output channel 3-data	5
Output channel 3-ground	6
Output channel 4-data	7
Output channel 4-ground	8

Drawing and connection

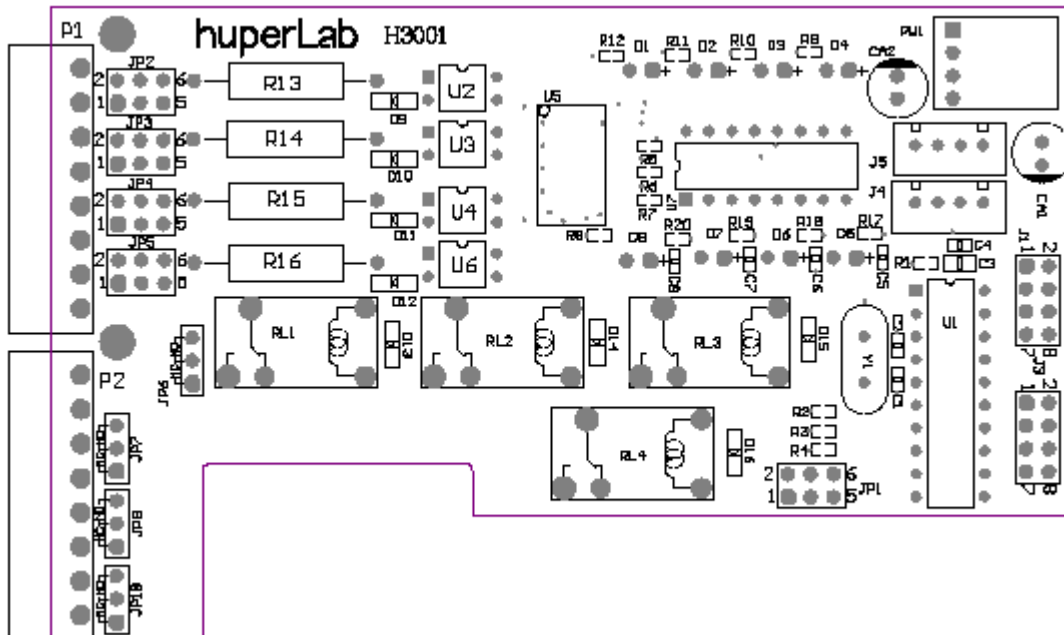

IOP-0404P (H3001) Dimension

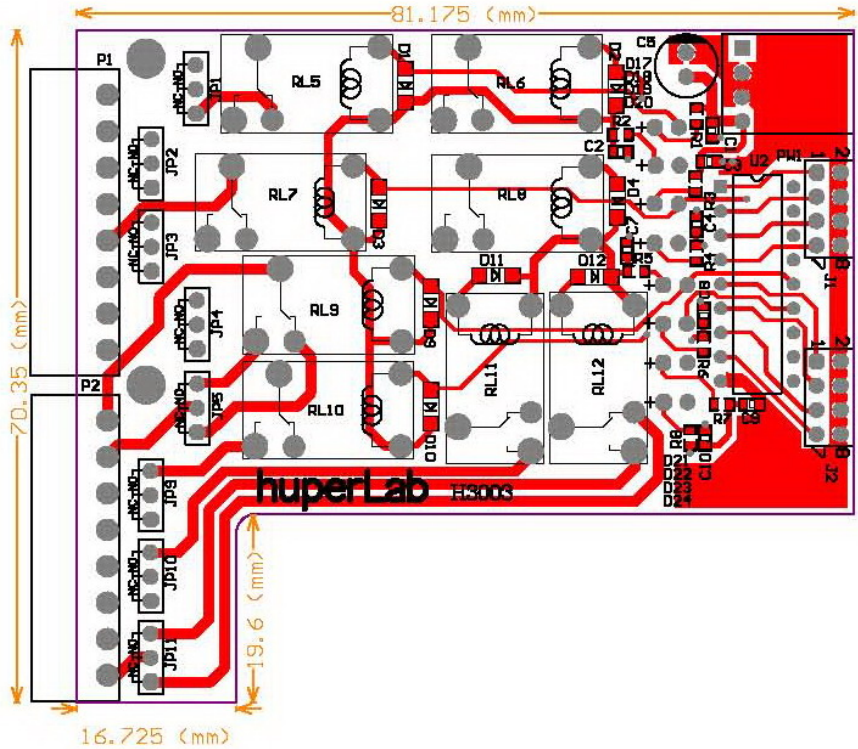

Settings at huperVision

After installing the IOC-0404P I/O card, you can open the Preferences dialog box: Device tab of huperVision to customize I/O settings.

Input Settings

- Step 1: Open the Preferences dialog box, then click the Device/Input tab.
- Step 2: Select "BT878-GPIO-1" item from the Card list.
- Step 3: The 4 input ports of IOC-0404P map to input 1, 2, 5 and 6 in the settings. Please do not select input 3, 4, 7 and 8 in the settings.
- Step 4: Click the Test button to open the "Sensor test" dialog box to examine correct input value and status.

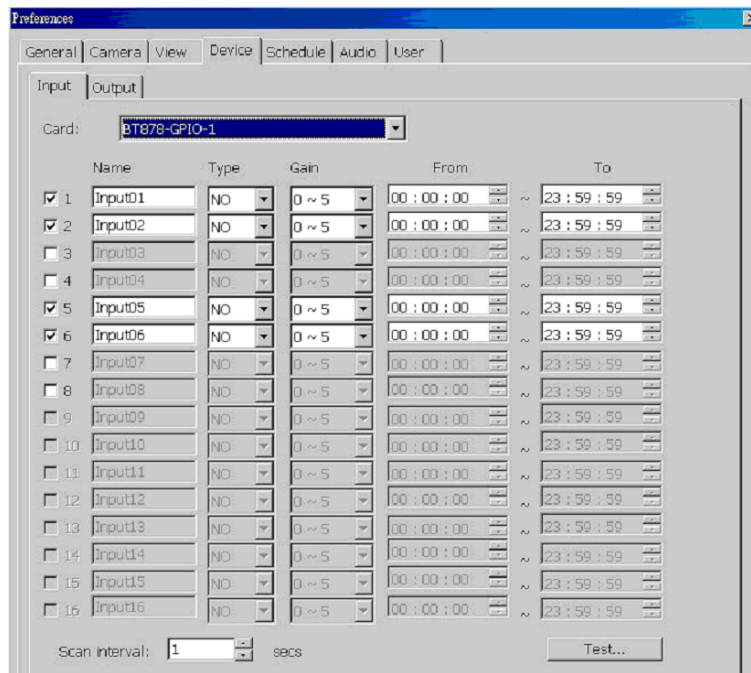

Note: If IO-0404P connects to two capture cards, the number of input pins are 8. They are input 1, 2, 5, 6, 9, 10, 13 and 14.

Output Settings

- Step 1: Open the Preferences dialog box, then click the Device/Output
- Step 2: Select "BT878-GPIO-1" from the Card
- Step 3: The 4 output ports of IOC-0404P map to output 3, 4, 7 and 8 in the settings. Please do not select output 1, 2, 5 and 6 in the settings.
- Step 4: Click the Test button to examine the response of connected output devices.

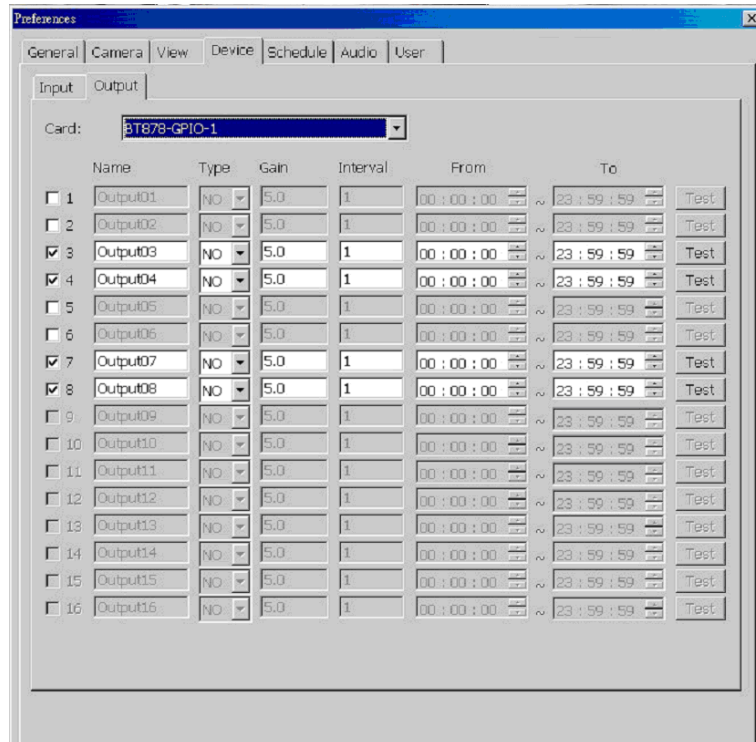

Note: If IO-0404P connects to two capture cards, there are total 8 output pins. They are output 3, 4, 7, 8, 11, 12, 15 and 16.

Appendix 6

IOB-0805 BOX Guide



Technical Specification

CE Approved

Digital Contact Input Isolation	8
5000Vrms Digital Level 0	Open
Digital Level 1	Close
Relay Output	5
Relay Type	Form A
Contact Rating	10A@125VAC, 5A@250VAC/30VDC Operate
Time	8 ms
Release Time	5 ms Dielectric
Strength	2500VAC Electrical
life(min.)	1×10^5
Mechanical life(min.)	1×10^7
Power Consumption	110 / 220 VAC or 5VDC, 5W°C
Communication Port	RS232 / RS485 (Protocol : Huper RTU ASCII) RS232:1200 – 115, 200 bps; RS485 : 1200 – 921.6K bps
Communication Distance	RS232: 50 feet RS485: 4000 feet
Input Power Supply	110 / 220 VAC or 5VDC, Digital Input;G 5/12/24 VDC
Dimension	150 x 100 x 40 mm
Weight	360 g
Approved Standards	CE

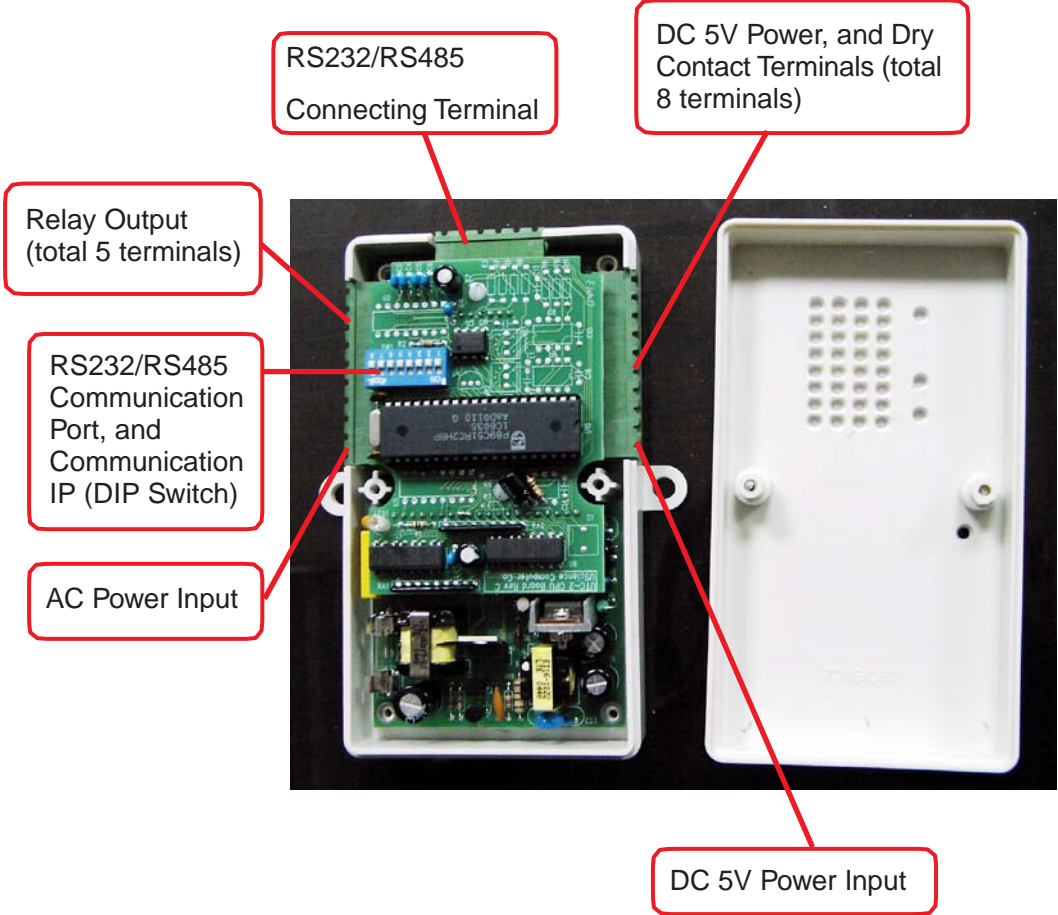

Installation

110 / 220 VAC Power Supply Wiring

DC+5V power supply CANNOT be used together with the AC power supply.

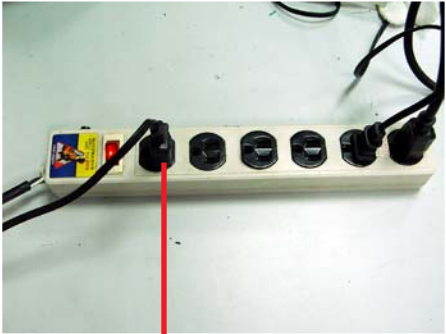

Connect to AC power supply

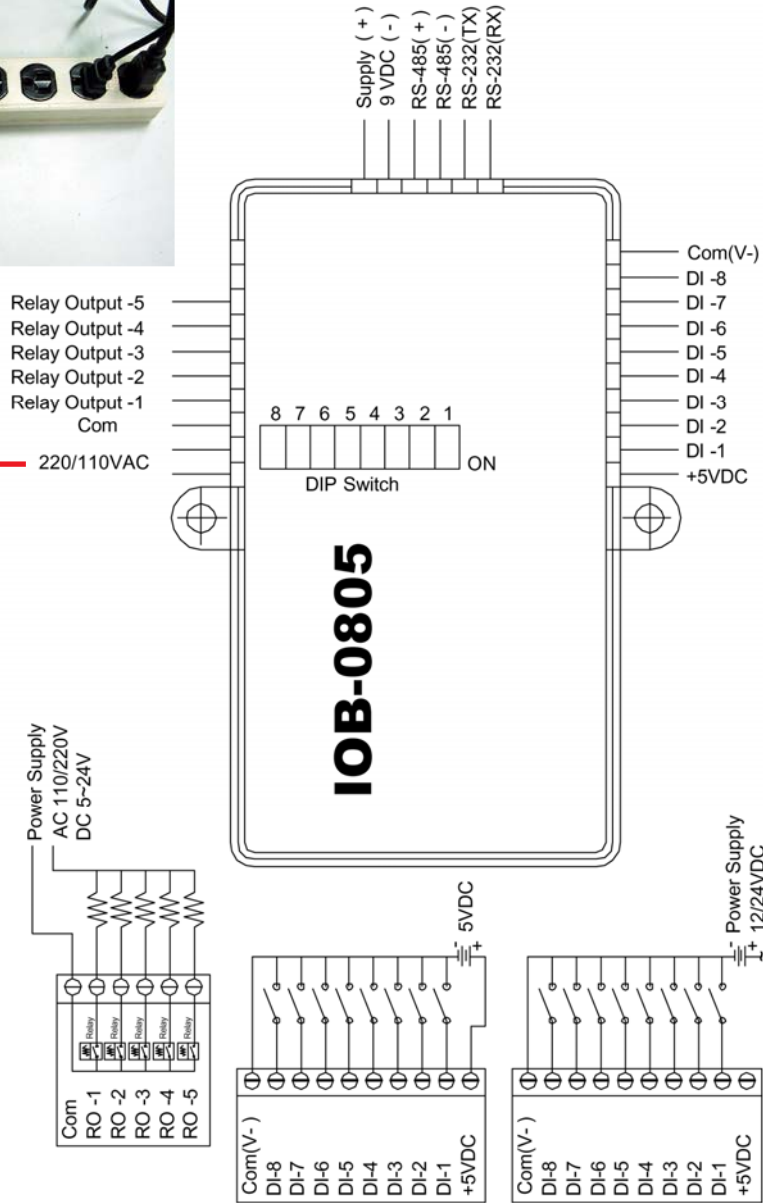

DC +5V Power Supply Wiring (When 5 relays are concurrently in use for a long time.
 DC+5V power supply CANNOT be used together with the AC power supply.

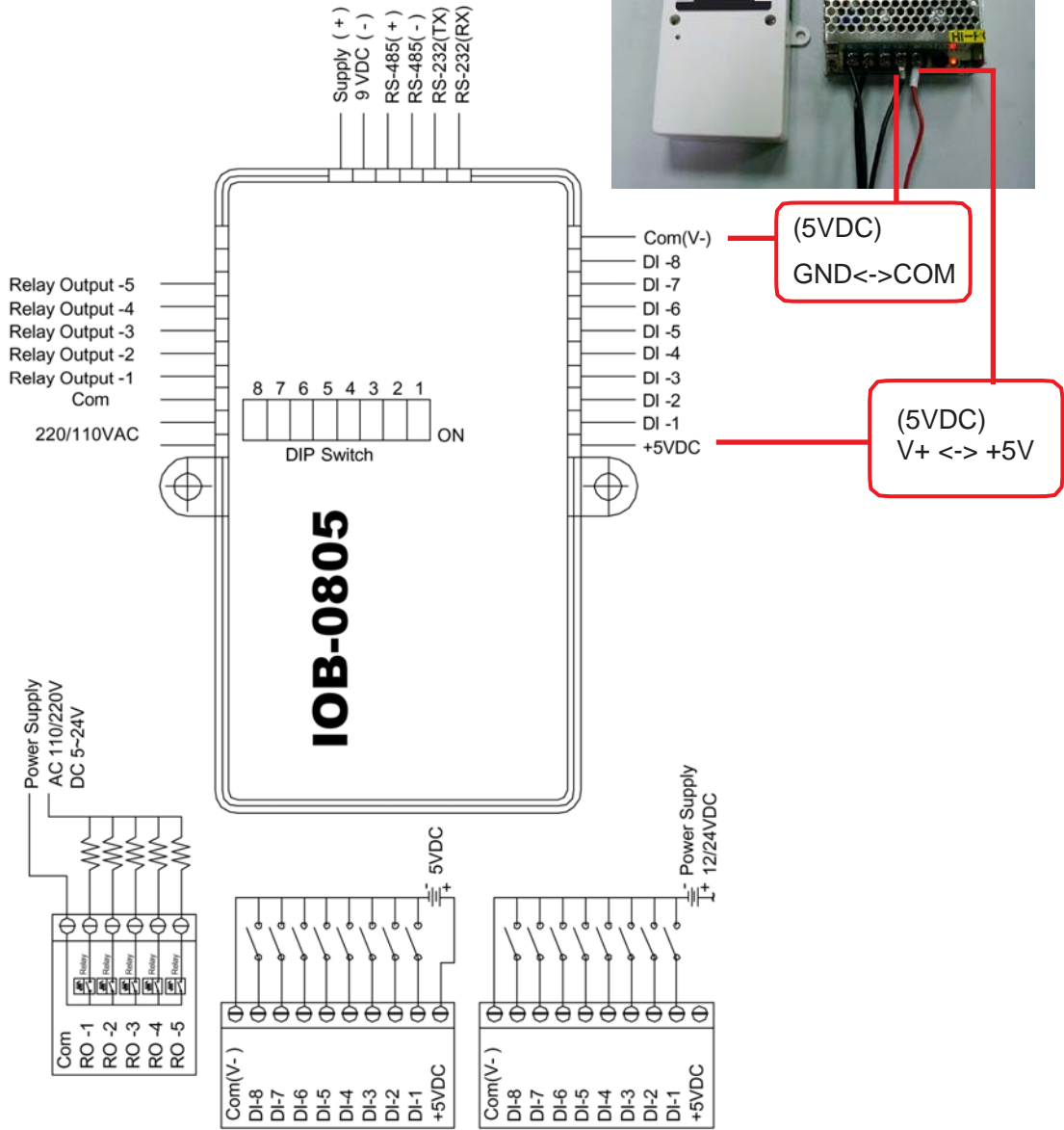
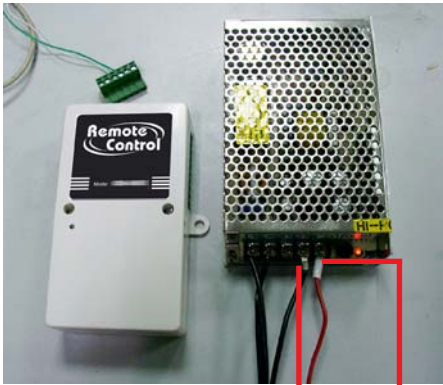

DVR Using RS232 Com Port

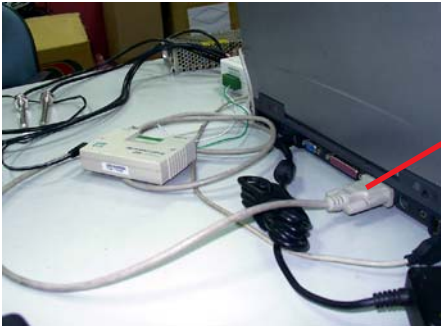

Connect to RS232 Port
(DVR using COM Port)

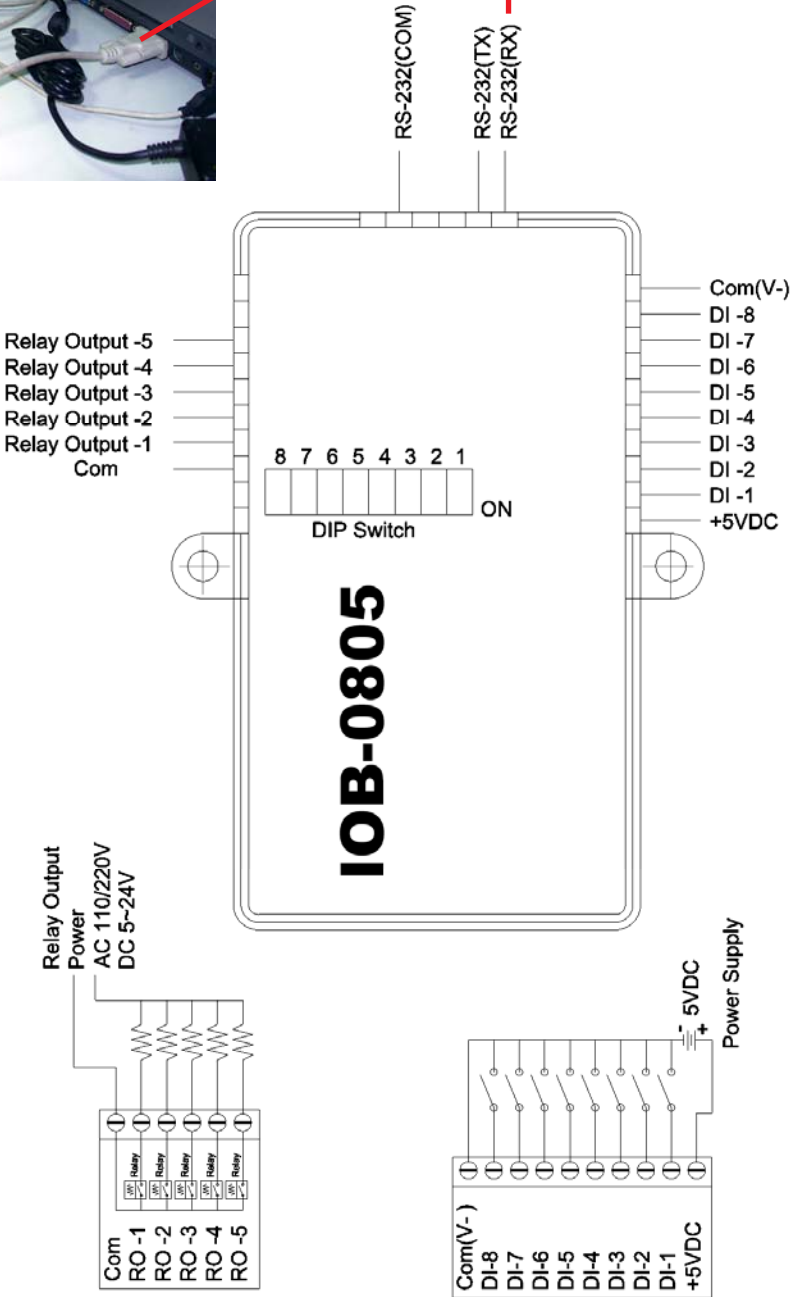

DVR Using USB to Connect to RS232 Com Port

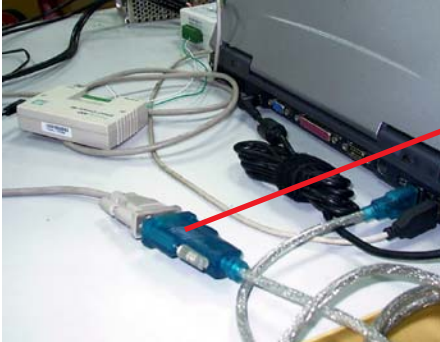

Connect to USB/RS232 converter (DVR without)

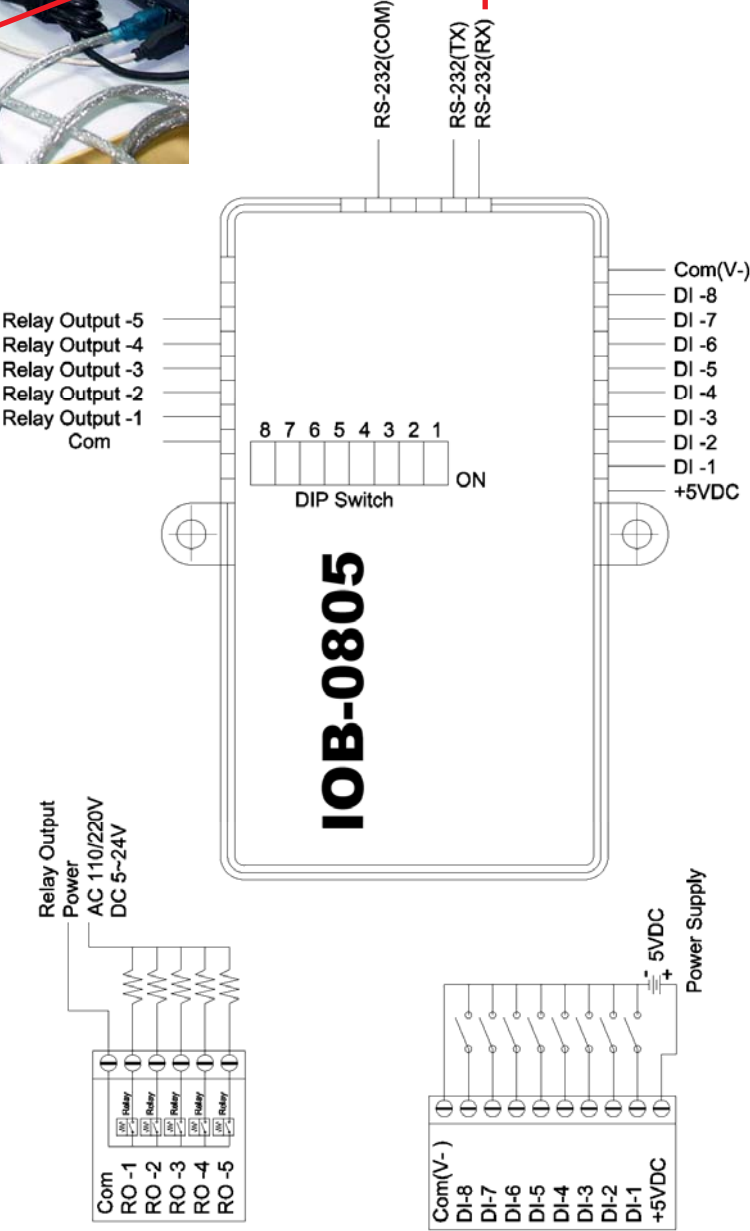

DVR Using USB to Connect to RS485 Com Port

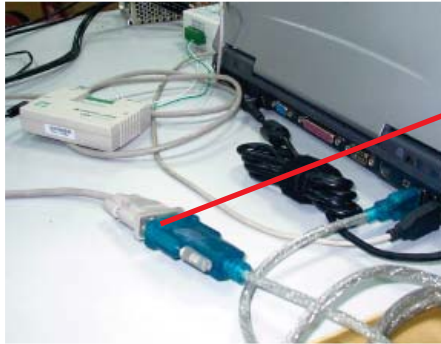

Connect to USB/RS485 converter
(DVR without COM Port or for
long distance usage)

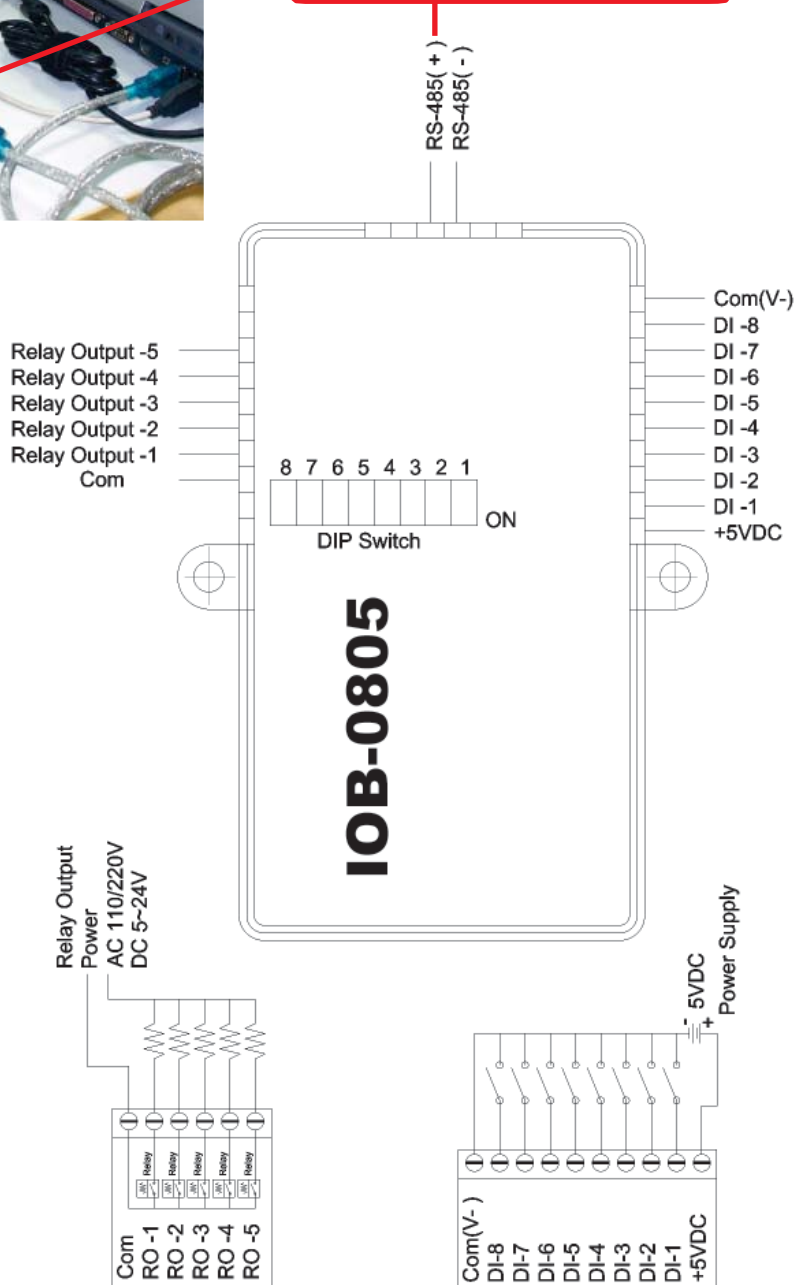

RS232/RS485 Communication Port and IP (DIP Switch) Settings

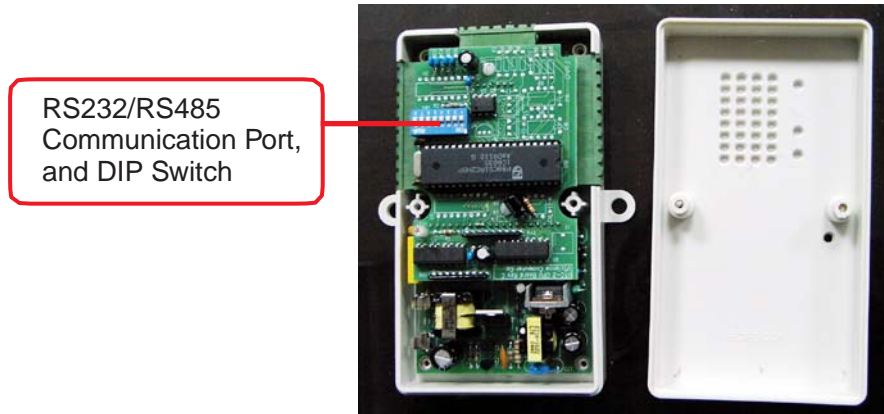

- (1) DIP Switch Default: RS232, ID=1
- (2) DIP Switch Setting: The DIP Switch is "OFF" by default which locates at the ID display side. Shift to the other side to turn the DIP Switch "ON."

Options for Communication Ports

DIP Switch	NO. 1	NO. 2
Comm. Port		
RS-232	OFF	ON
OFF	ON	OFF

Note: NO.1 and NO.2 cannot be turned on at the same time; i.e. RS-232 and RS-485 cannot be is use concurrently.

- (1) NO.3 ~ NO.8 are node ID (a binary system)
- (2) If NO.3 is ON and others are OFF, it means 01.
- (3) If NO.4 is ON and others are OFF, it means 02.
- (4) If NO.5 is ON and others are OFF, it means 04.
- (5) If NO.6 is ON and others are OFF, it means 08.
- (6) If NO.7 is ON and others are OFF, it means 16.
- (7) If NO.8 is ON and others are OFF, it means 32.

Example:

- If node ID is 1, the DIP Switch setting should be NO.3 is ON and others are OFF.
- If node ID is 3, the DIP Switch setting should be NO.3 and NO.4 are ON, and others are OFF.
- If node ID is 5, the DIP Switch setting should be NO.3 and NO.5 are ON, and NO.4 and others are OFF.
- If node ID is 7, the DIP Switch setting should be NO.3~NO.5 are ON, and NO.6 ~ NO.8 are OFF.
- The Node ID is the sum of DIP Switch NO.3 to NO.8.

Input/Output Pin

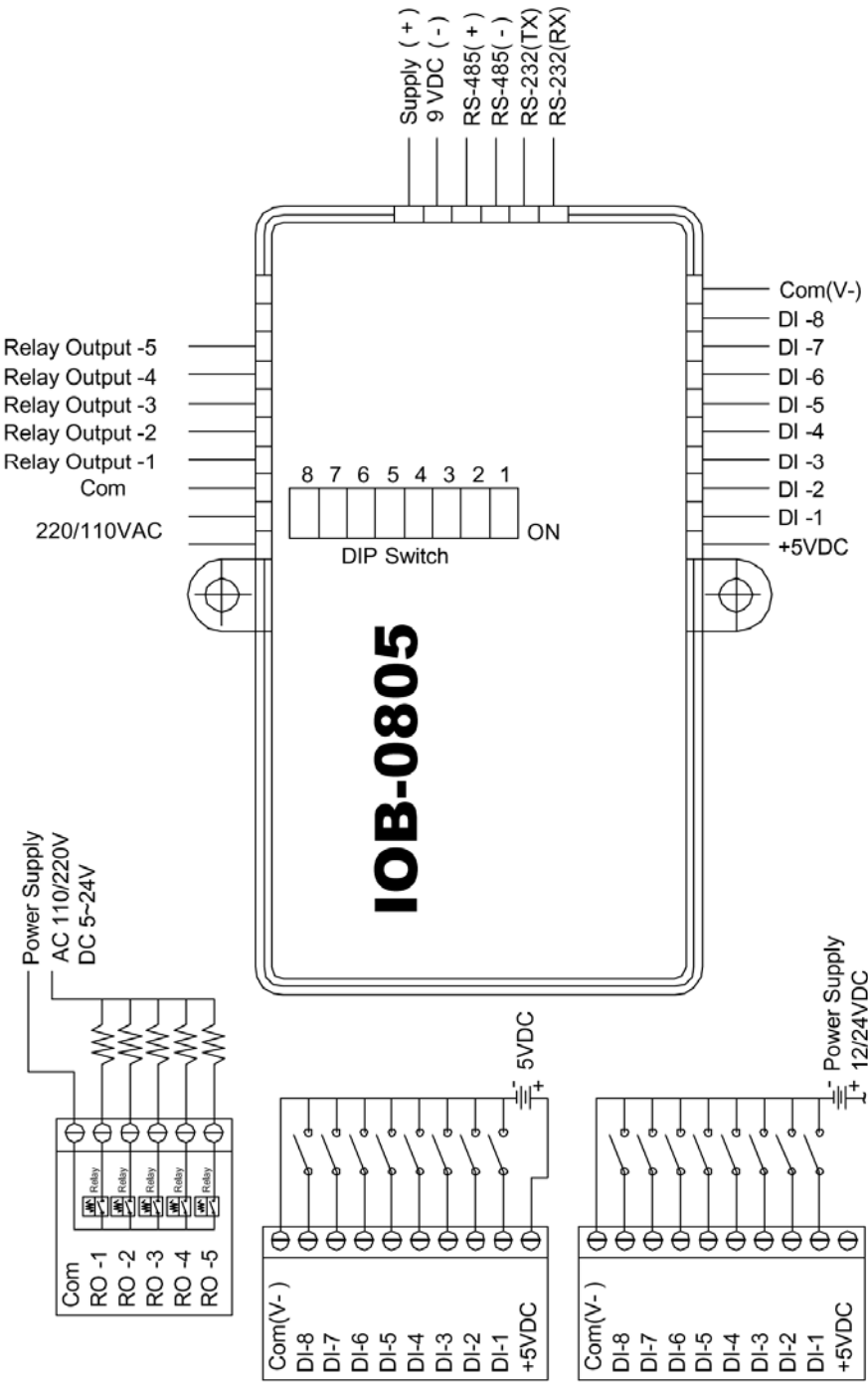

DI Input Control

1. Connect the COM port to -VDC. The COM port cannot be connected to +VDC. The acceptable voltage is DC5V~DC24V.
2. 8 DI controls share the same power supply which accepts different levels of voltage starting from DC5V to DC24V.
3. IOB-0805 provides 5VDC for DI input control when the power supply is 110/220 VAC. No extra DC power supply is necessary.
4. When 5 relay output controls are in long-term use, an extra 5VDC power supply is necessary.
5. Please DO NOT turn on the AC power supply while the DC +5V is in use.

Application Example: Alarm Detection (Contact Input)

IOB-0805 provides 5VDC for DI input control when the power supply is 110/220 VAC. No extra DC power supply is necessary.

IOB-0805 DI Wiring Example A: Fire Alarm Detection (Contact Input) Using AC Power Supply

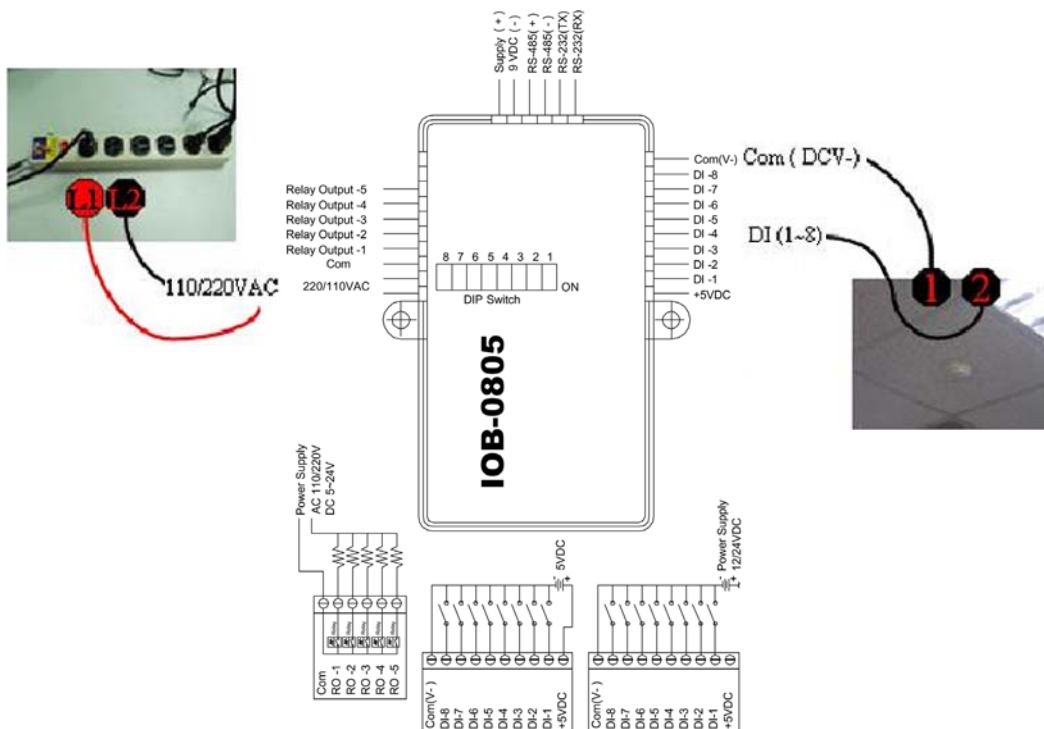

Application Example: Alarm Detection (Contact Input)

When 5 relay output controls are in long-term use, an extra 5VDC power supply is necessary.

IOB-0805 DI Wiring Example B: Fire Alarm Detection (Contact Input) Using DC Power Supply.

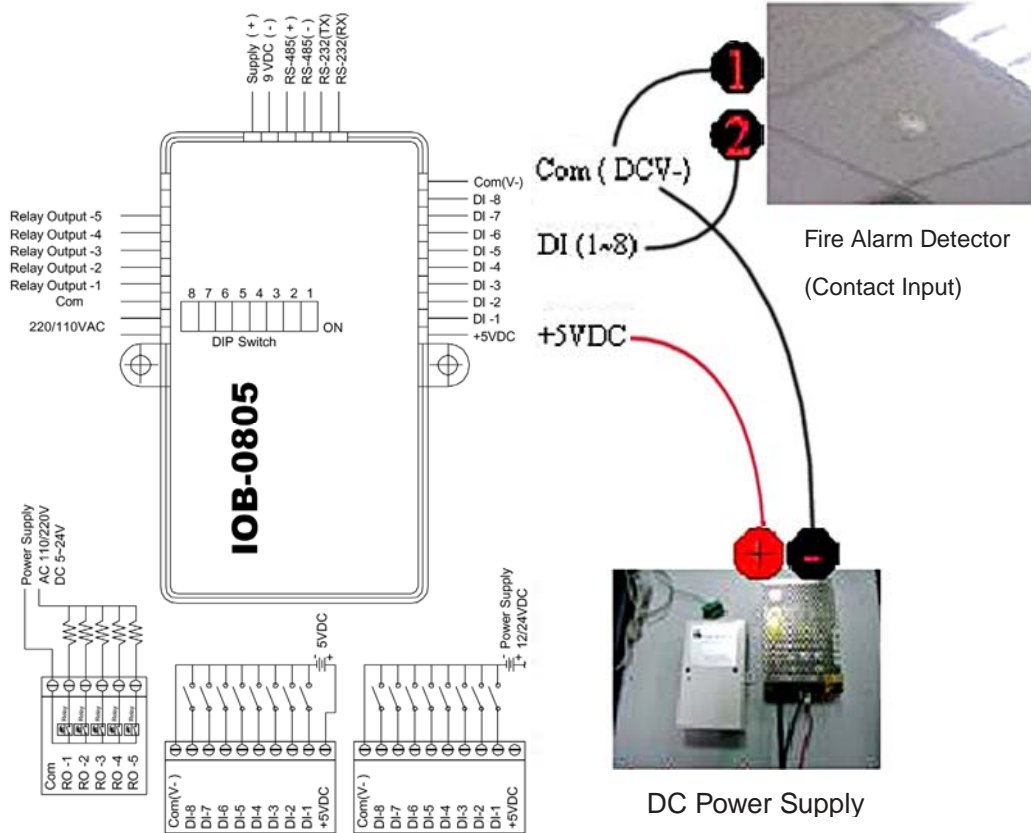

RO (5A Relay Dry Contact) Output Control

5 RO controls share the same power supply, and accept different levels of voltage. All the power supplies must be the same type, i.e. AC or DC.

Application Example: Alarm Indicator (AC)

IOB-0805 RO Wiring Example A: Alarm Indicator (AC)

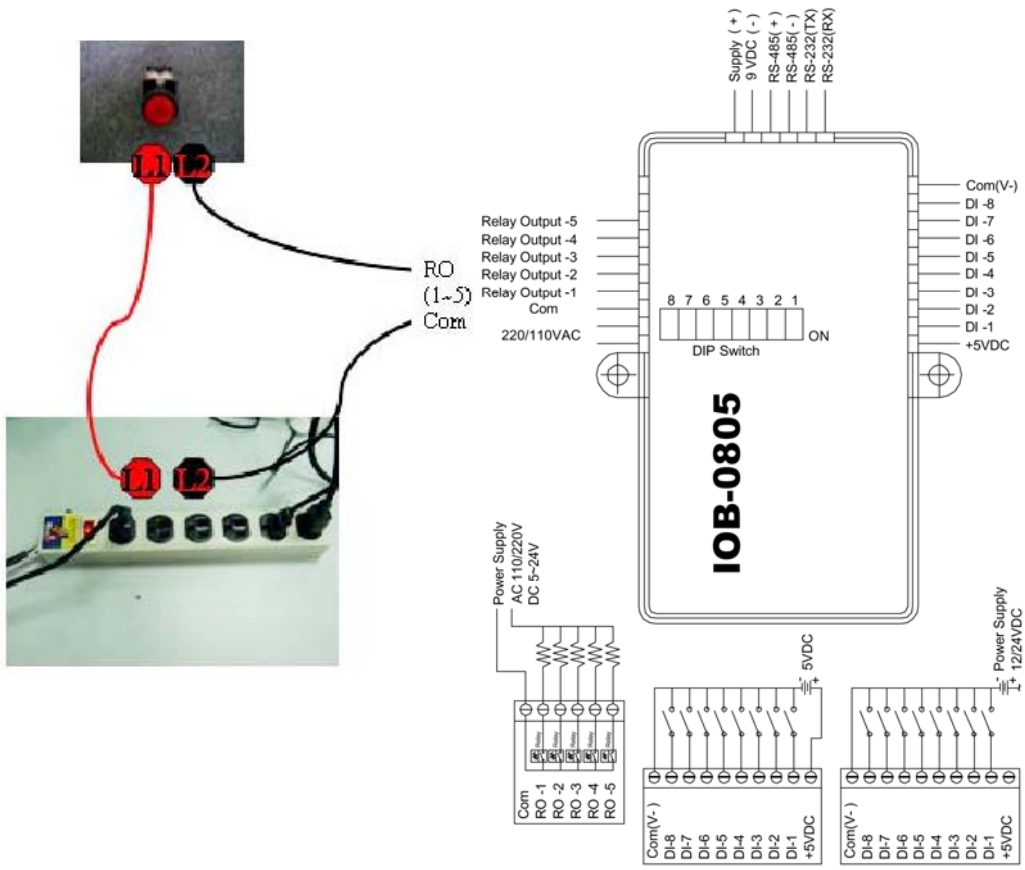

Application Example: Small Fan or TV Set (under 5A)

IOB-0805 RO Wiring Example B: Small Fan or TV Set (under 5A)

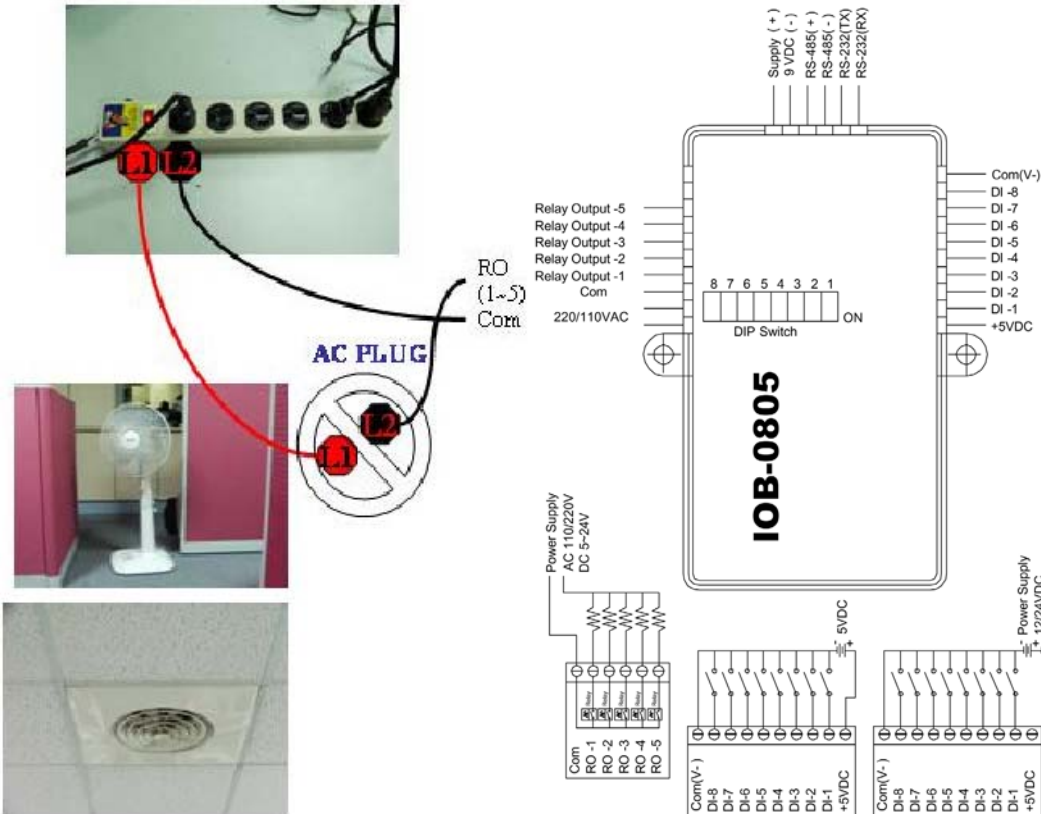

Application Example: Refrigerator, Rice Cooker or Microwave (70~240VAC)

Note: Please use the relay, SSR or AC power supply with enough contact ratings to avoid danger.
The AC wire should be 3.5 mm when the power consumption is above 15A.

1. For the appliances whose power consumption is under 15A, such as refrigerators, rice cookers, microwaves, washers, small coolers and heaters, the AC wire needs to be 2.0 mm.
2. As for the large-sized appliances, like air conditioners and heaters, etc. whose power consumption is above 15A, the AC wire must be at least 3.5 mm or above.

IOB-0805 RO Wiring Example C: 15A/240V AC SSR or Relay (AC Control)

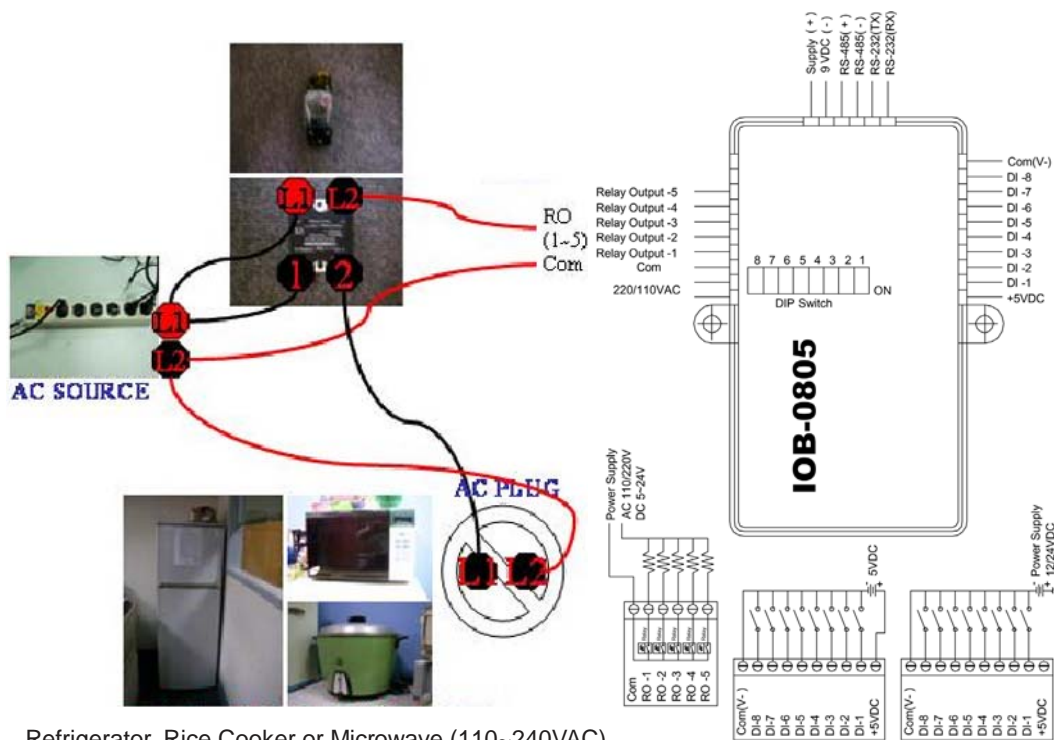

Refrigerator, Rice Cooker or Microwave (110~240VAC)

Application Example: Refrigerator, Rice Cooker or Microwave (70~240VAC)

Note: Please use the relay, SSR or AC power supply with enough contact ratings to avoid danger.

The AC wire should be 3.5 mm when the power consumption is above 15A.

1. For the appliances whose power consumption is under 15A, such as refrigerators, rice cookers, microwaves, washers, small coolers and heaters, the AC wire needs to be 2.0 mm.
2. As for the large-sized appliances, like air conditioners and heaters, etc. whose power consumption is above 15A, the AC wire must be at least 3.5 mm or above.

IOB-0805 RO Wiring Example D: 15A/240V AC SSR or Relay (DC Control)

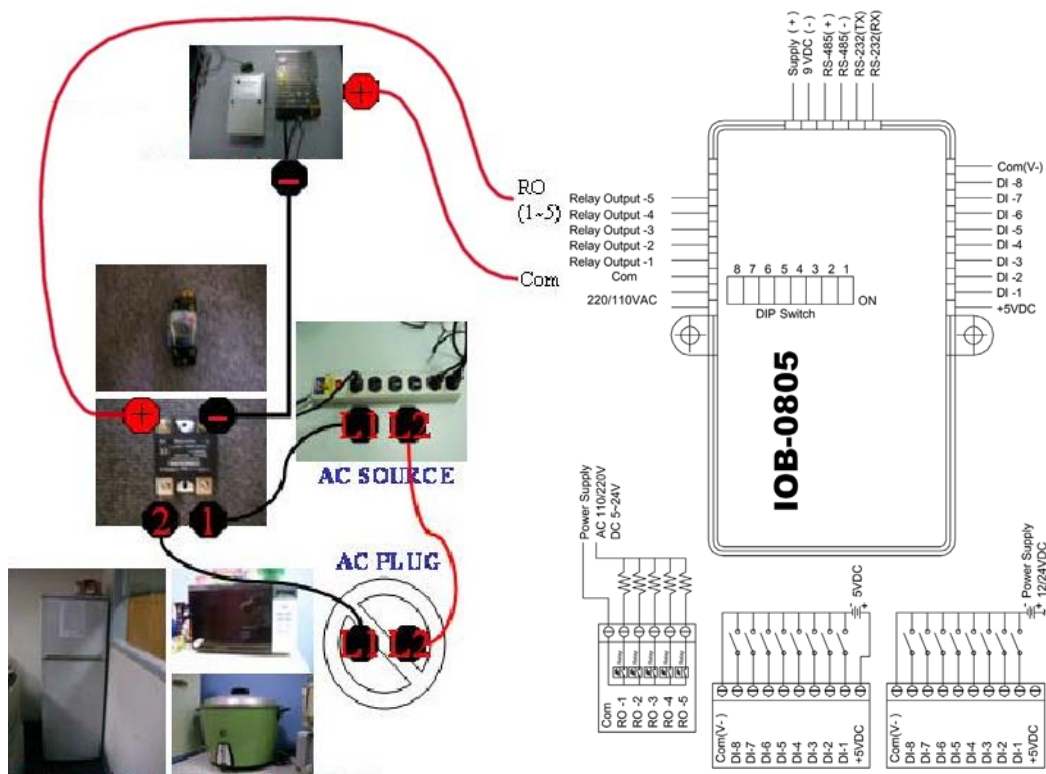

Refrigerator, Rice Cooker or Microwave (110~240VAC)

Settings at huperVision

After installing the IOB-0805 I/O box, follow the steps below.

1. Please find the bin folder in the directory C:/Program Files/huperLab/huperVision/bin. (Close the DVR server).
2. Open the bin folder, then find the IOBoxTester.exe file. (See below).

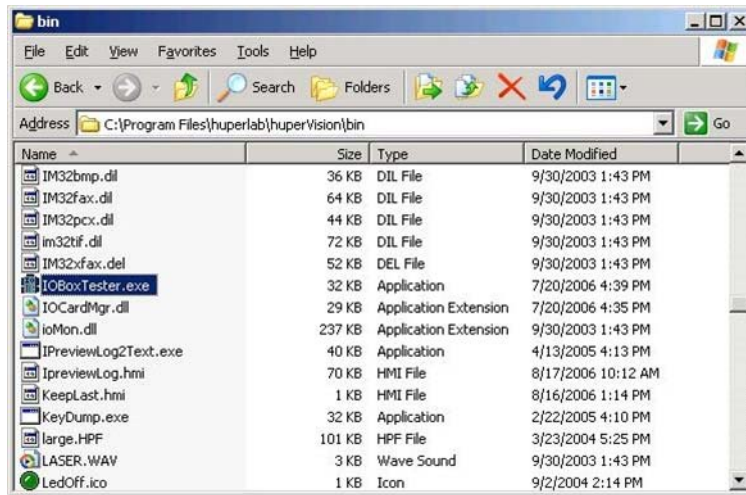

3. Double-click to run IOBoxTester.exe, then click the Scan button (see below).

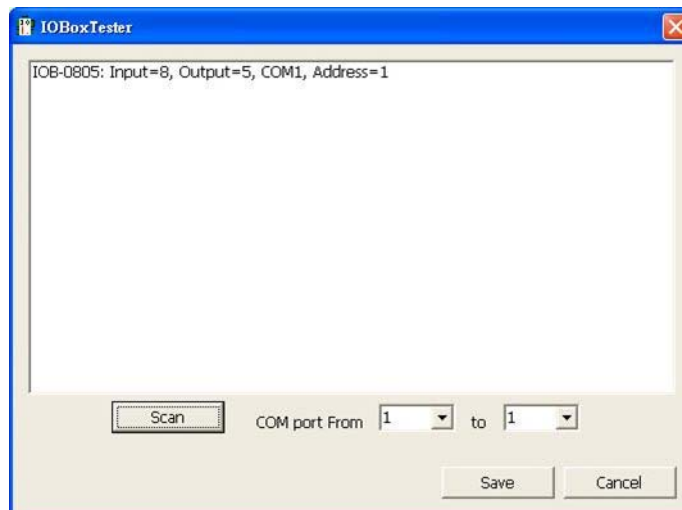

4. After the scan is completed, click the Save button.
5. After you restart the DVR site server. IO Box will be detected by the DVR in the Device tab of the Preferences dialog box.

Input Settings

- Step 1: Open the Preferences dialog box, click the Device/Input tab.
- Step 2: Select the item "IOB-0805(1)" from the Device drop-down list.
- Step 3: 8 input ports are then displayed, and their assigned numbers start from 1 to 8.

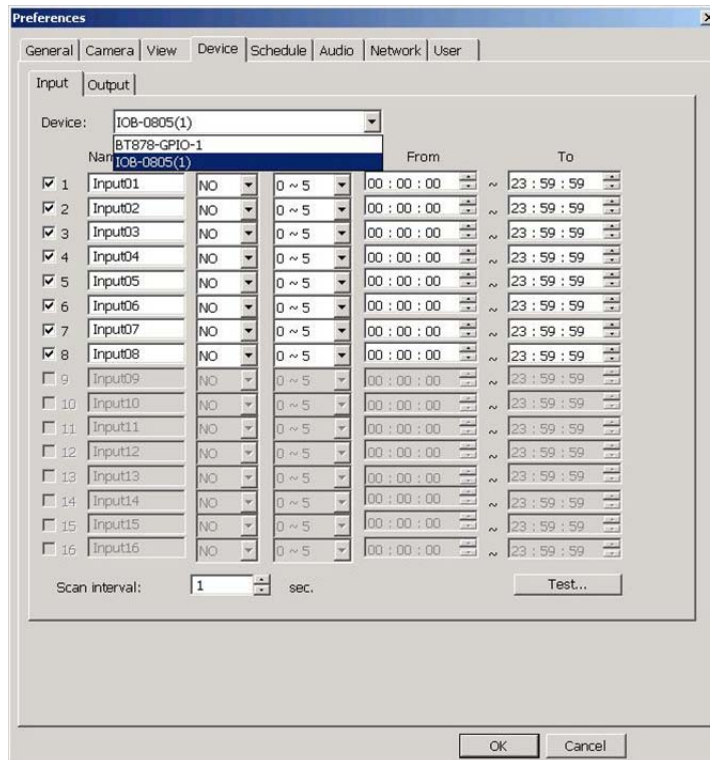

Output Settings

- Step 1: Open the Preferences dialog box, click the Device/Output tab.
- Step 2: Select the item "IOB-0805(1)" from the Device drop-down list.
- Step 3: 8 input ports are then displayed, and their assigned numbers start from 1 to 5.

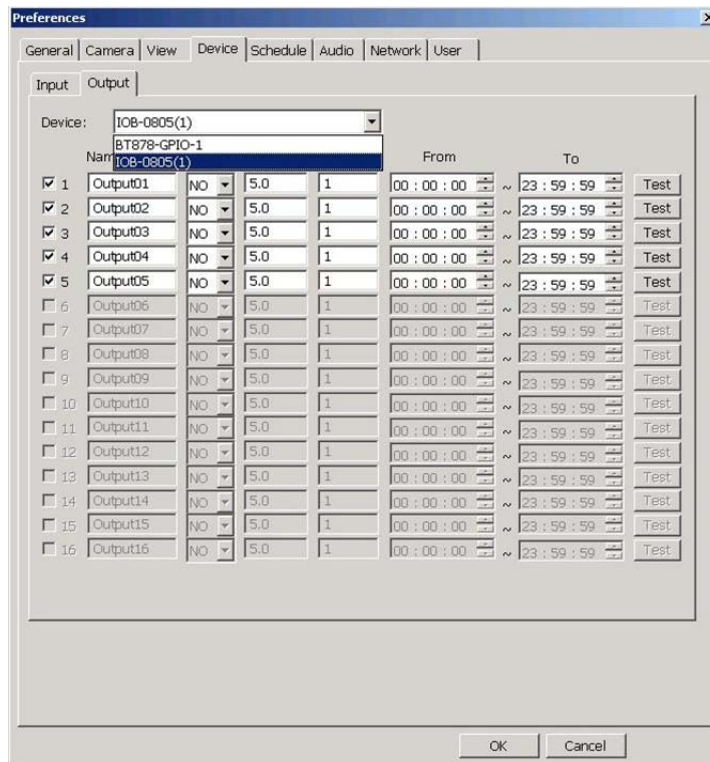

Appendix 7

IOB-1616 BOX Guide



CE Approved

Technical Specification

Digital Contact Input Isolation	16
5000Vrms Digital Level 0	Open
Digital Level 1	Close
Open Collector Output	16
Isolation	5000 Vrms
Load Voltage	5/12/24 VDC
Max Load Current	500 ma (2A Per Common Group) Power
Consumption	5W
Communication port	RS232 / RS485 (Protocol : Huper RTU ASCII) RS232 : 1200 – 115,200 bps ; RS485 : 1200 – 921.6K bps
Communication distance	RS232 : 50 feet RS485 : 4000 feet
Input Power Supply	12 VDC (9 ~ 12V), 5 W
Dimension	150 x 100 x 40 mm
Weight	360 g
Approved Standards	CE

Introduction

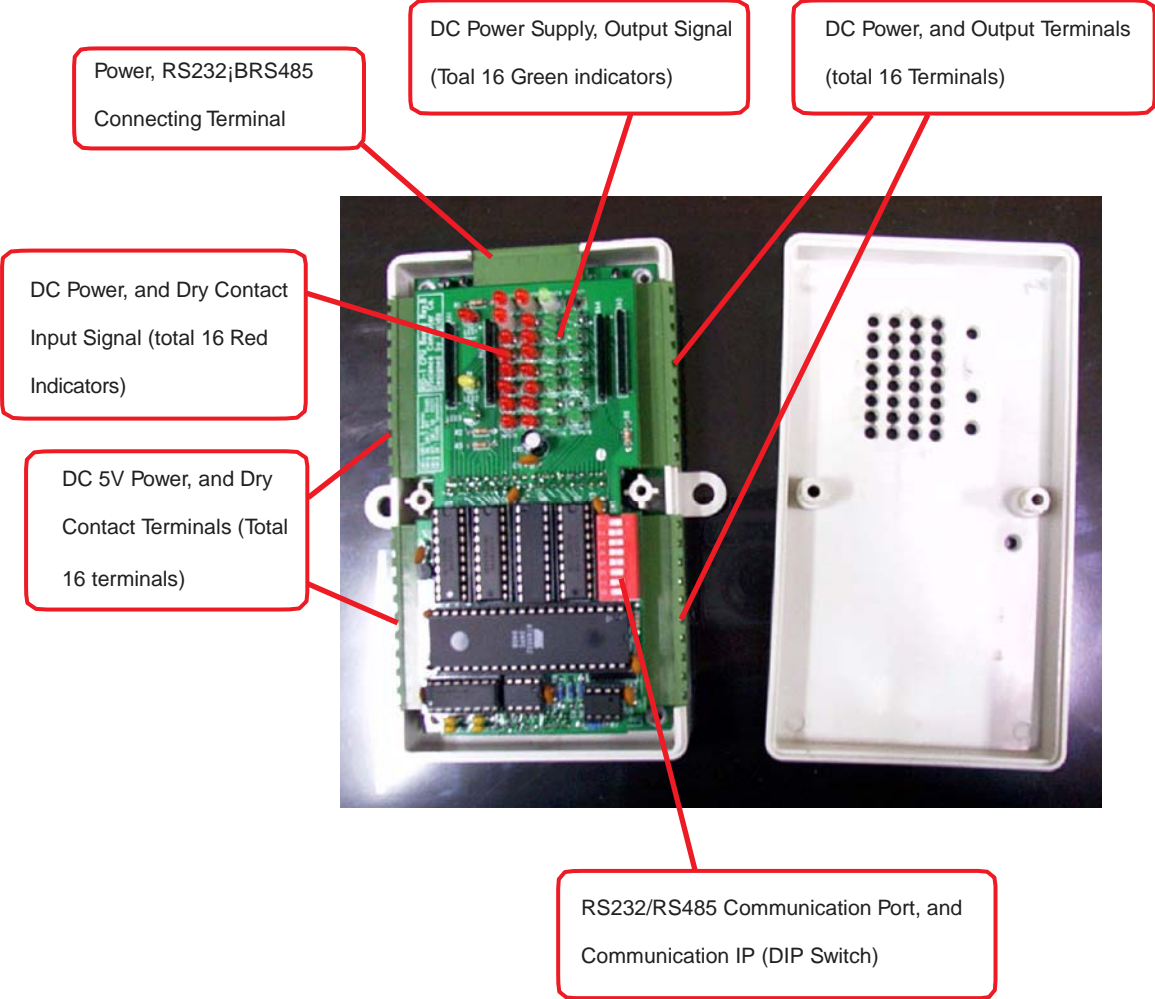

Installation

DVR Using RS232 Com Port



Connect to DC power supply

Connect to RS232 Port (DVR)

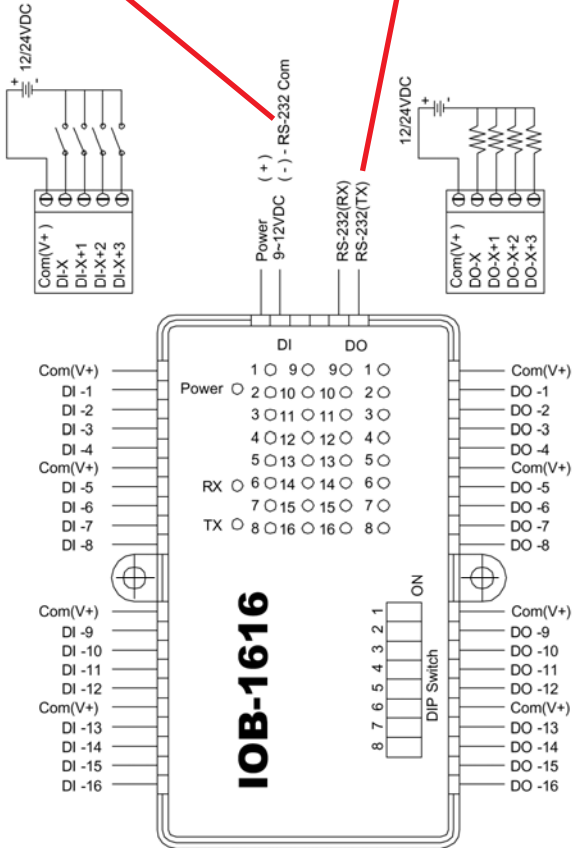

DVR Using USB to Connect to RS232 Com Port

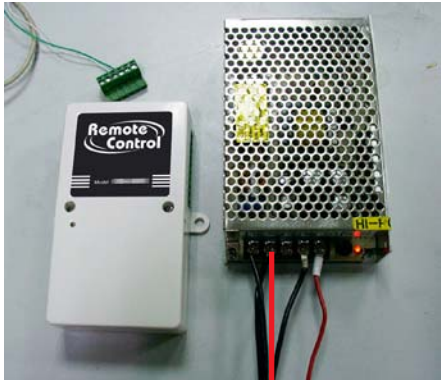

Connect to DC power supply (Power consumption: 12VDC)

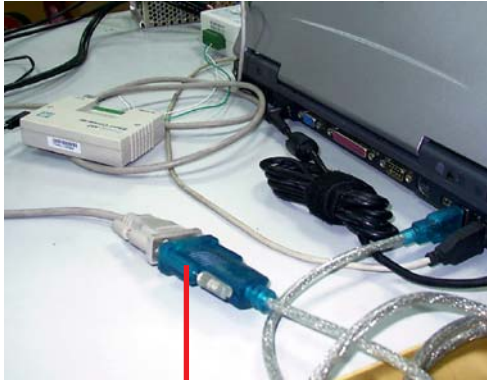

Connect to USB/RS232 converter (DVR without COM Port)

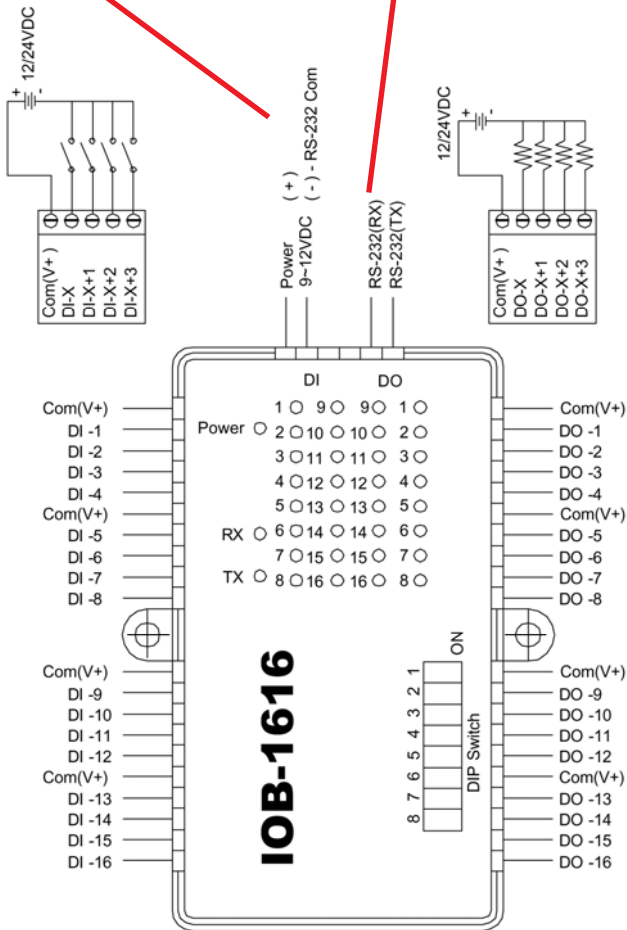

DVR Using USB to Connect to RS485 Com Port



Connect to DC power supply
(Power consumption: 12VDC)



Connect to USB/RS485 converter
(DVR without COM Port or for long distance usage)

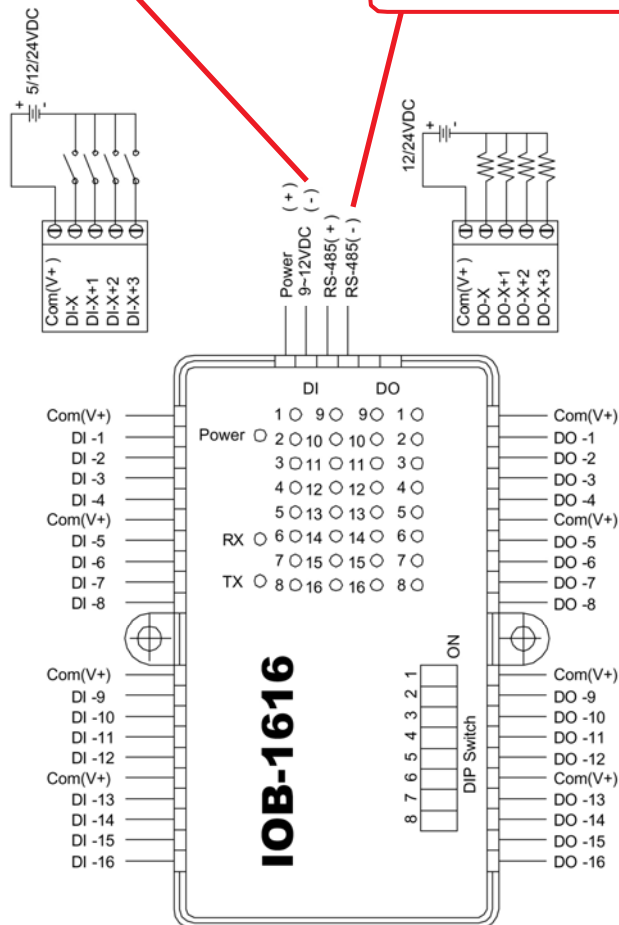

RS232/RS485 Communication Port and IP (DIP Switch) Settings

RS232/RS485
Communication Port, and
DIP Switch

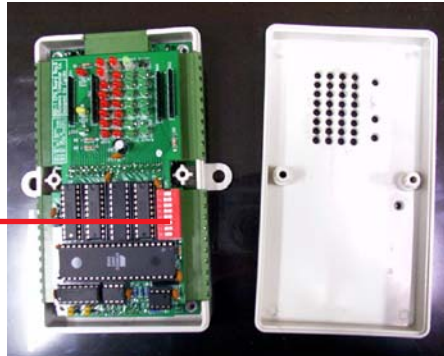

- (1) DIP Switch Default: RS232, ID=1
- (2) DIP Switch Setting: The default of DIP Switch is "OFF" which locates at the ID display side. Shit to the other side to turn the DIP Switch "ON."

Options for Communication Ports

DIP Switch	NO. 6	NO. 7	NO. 8
Comm. Port			
RS-232	OFF	ON	OFF
RS-485	ON	OFF	ON

Note: NO.6, NO.7 and NO.8 cannot be turned on at the same time; i.e. RS-232 and RS-485 cannot be in use concurrently.

- (1) NO.1 ~ NO.5 are node ID (a binary system)
- (2) If NO.1 is ON and others are OFF, it means 01.
- (3) If NO.2 is ON and others are OFF, it means 02.
- (4) If NO.3 is ON and others are OFF, it means 04.
- (5) If NO.4 is ON and others are OFF, it means 08.
- (6) If NO.5 is ON and others are OFF, it means 16.

Example:

- If node ID is 1, the DIP Switch setting should be NO.1 is ON and others are OFF.
- If node ID is 3, the DIP Switch setting should be NO.1 and NO.2 are ON, and others are OFF.

- If node ID is 5, the DIP Switch setting should be NO.1 and NO.3 are ON, and NO.2, NO.4 and NO.5 are OFF.
- If node ID is 7, the DIP Switch setting should be NO.1~NO.3 are ON, and NO.4 and NO.5 are OFF.
- The Node ID is the sum of DIP Switch NO.1 to NO.5.

Input/Output Pin

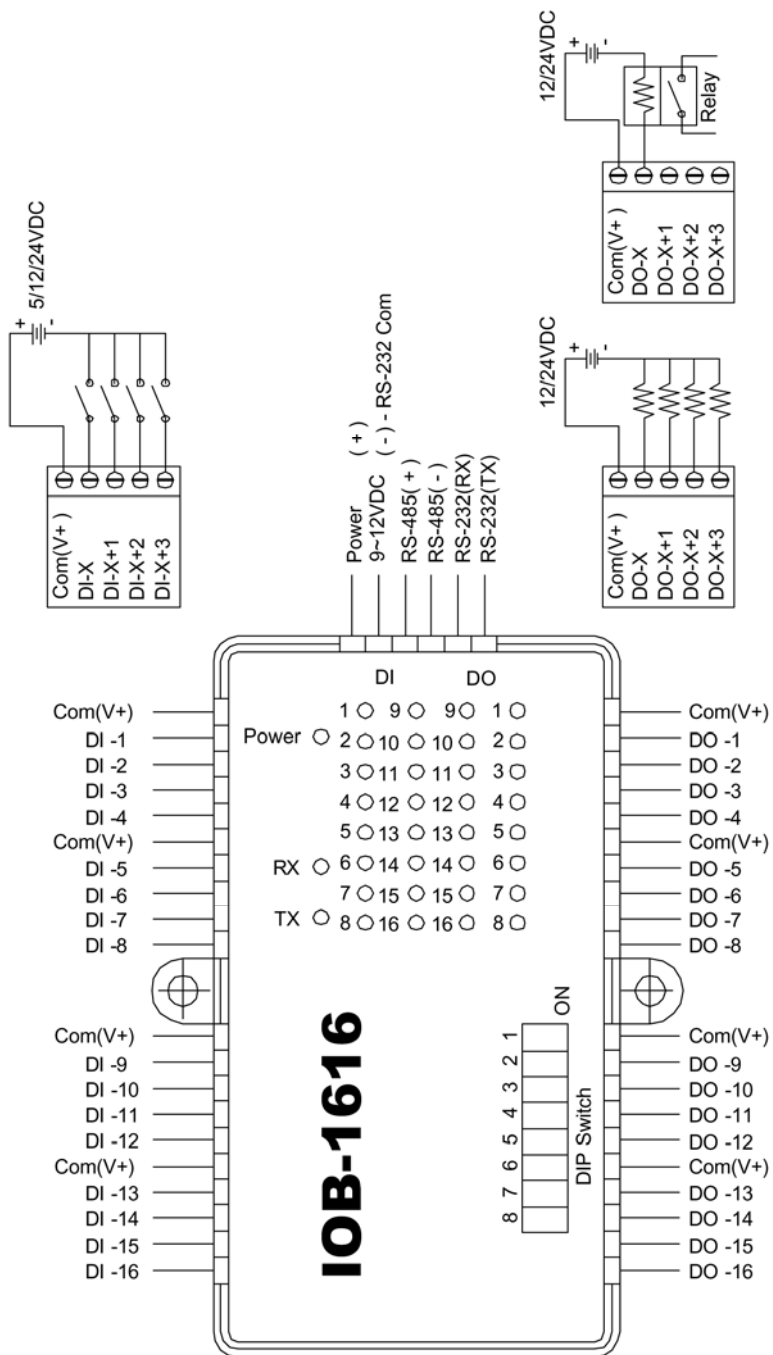

DI Input Control

- (1) Connect the COM port to +VDC. It's not allowed to connect to -VDC. The acceptable voltage is DC5V~DC24V.
- (2) 4 DI controls share the same power supply which accepts different levels of voltage starting fromDC5V to DC24V

Application Example: Alarm Detection (Contact Input)

IOB-1616 DI Wiring Example A: Fire Alarm Detection (Contact Input)

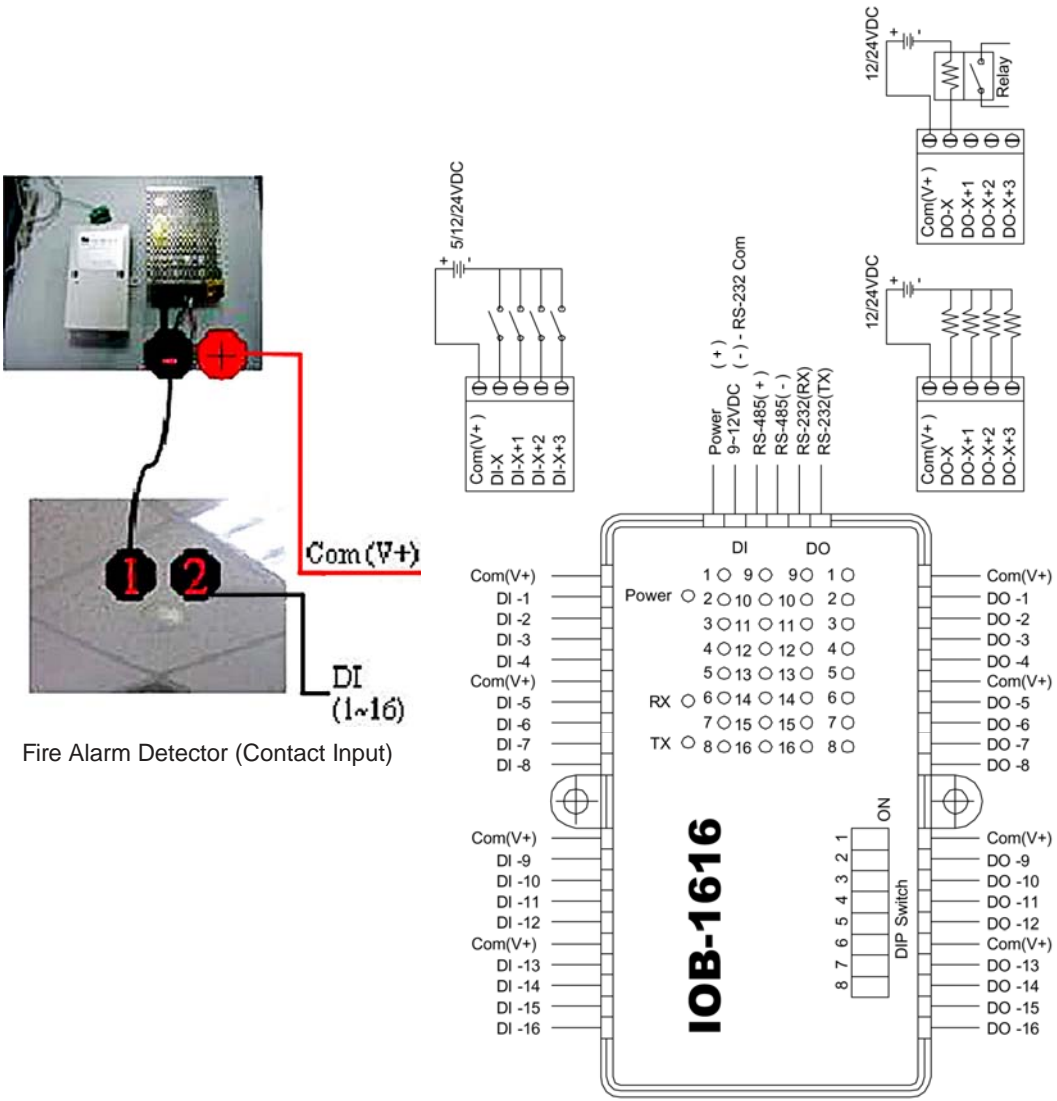

DO Output Control

- (1) Connect the COM port to +VDC. It's not allowed to connect to -VDC. The acceptable voltage is DC5V~DC24V.
- (2) 4 DI controls share the same power supply which accepts different levels of voltage starting from DC5V to DC24V

Application Example: Alarm Indicator (DC)
 IOB-1616 DO Wiring Example A: Alarm Indicator (DC)

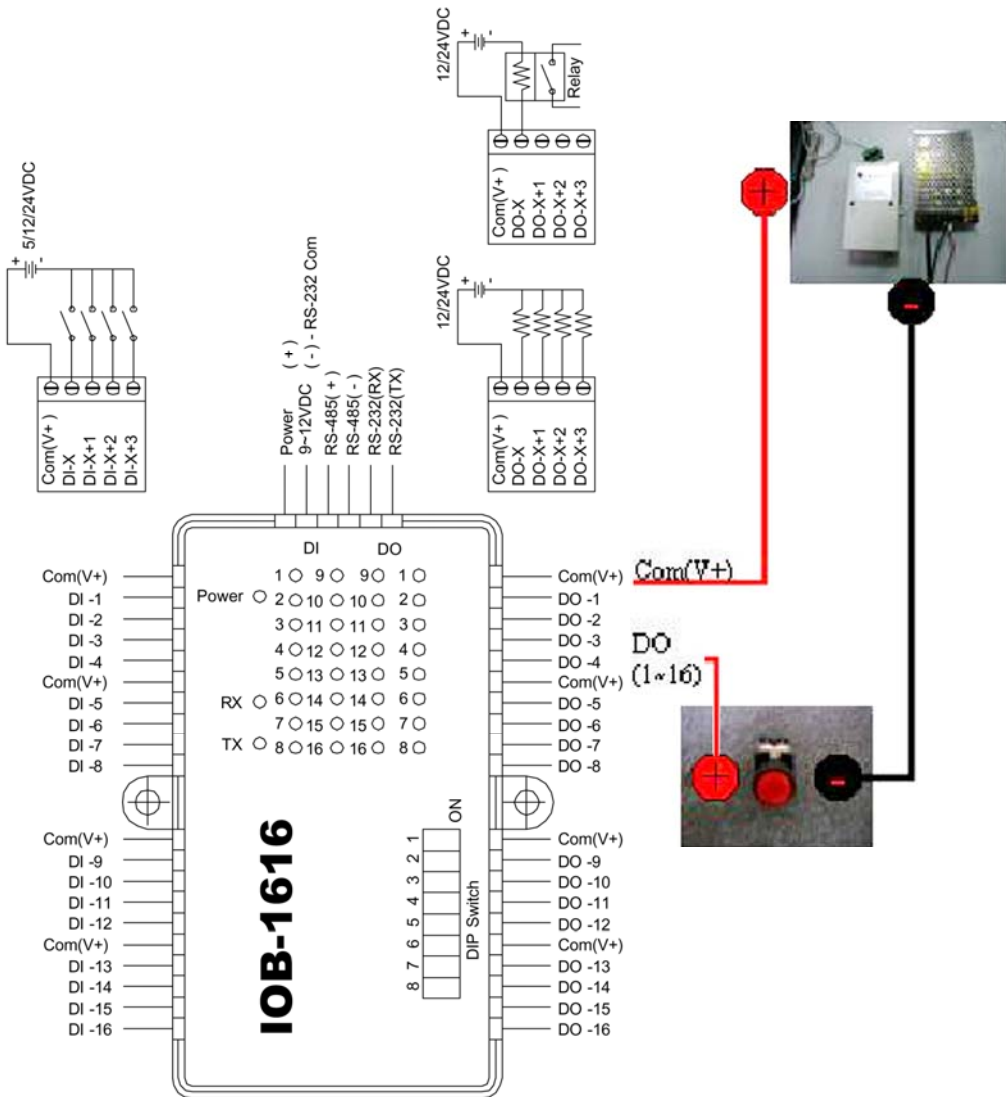

Application Example: Refrigerator, Rice Cooker or Microwave (70~240VAC)

Note: Please use the relay, SSR or AC power supply with enough contact ratings to avoid danger. The AC wire should be 3.5 mm when the power consumption is above 15A.

- (1) For the appliances whose power consumption is under 15A, such as refrigerators, rice cookers, microwaves, washers, small coolers and heaters, the AC wire needs to be 2.0 mm.
- (2) As for the large-sized appliances, like air conditioners and heaters, etc. whose power consumption is above 15A, the AC wire must be at least 3.5 mm or above.

IOB-1616 DO Wiring Example B: 15A/240V AC SSR or Relay (DC Control)

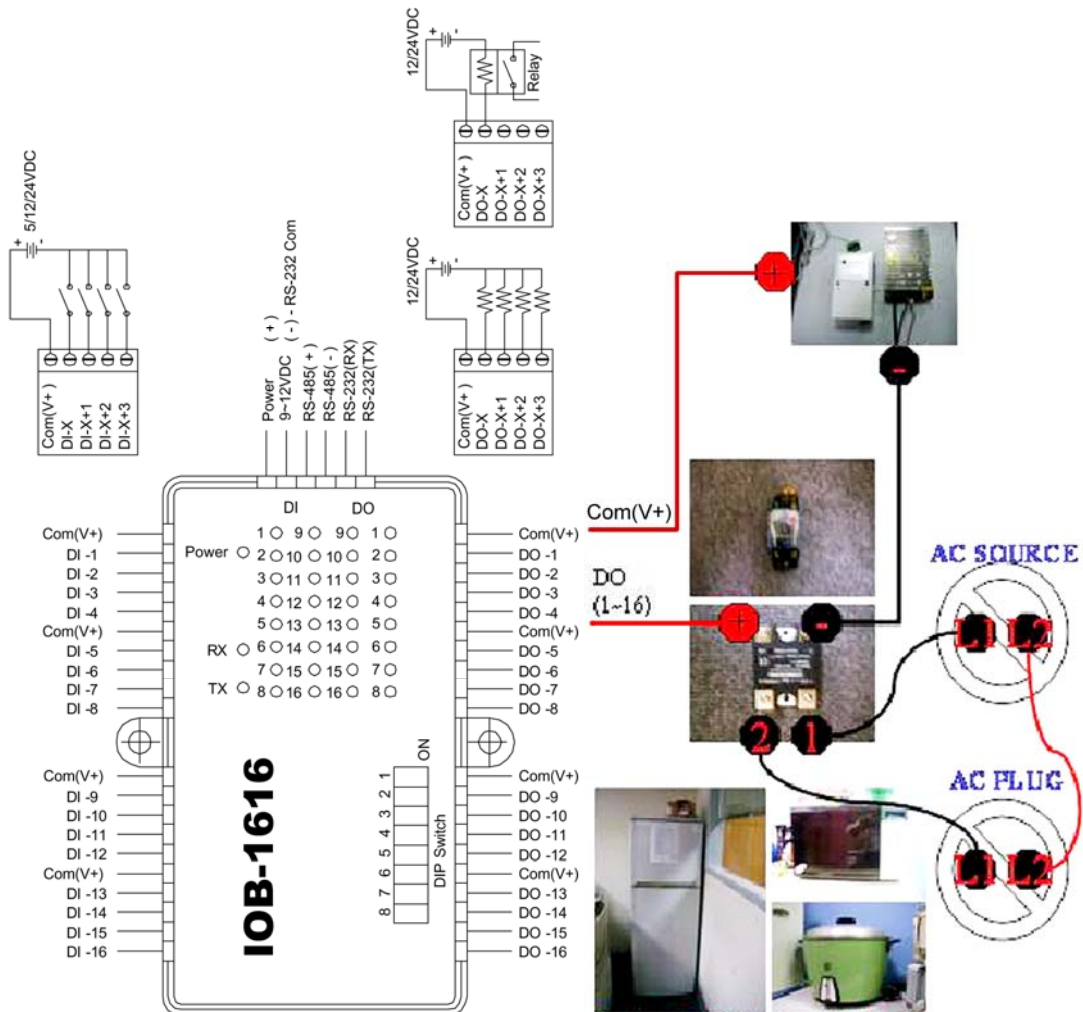

Refrigerator, Rice Cooker or Microwave (110~240VAC)

Settings at huperVision

After installing the IOB-1616 I/O box, follow the steps below.

1. Please find the bin folder in the directory C:/Program Files/huperLab/huperVision/bin. (Close the DVR server).
2. Open the bin folder, then find the IOBoxTester.exe file. (See below).

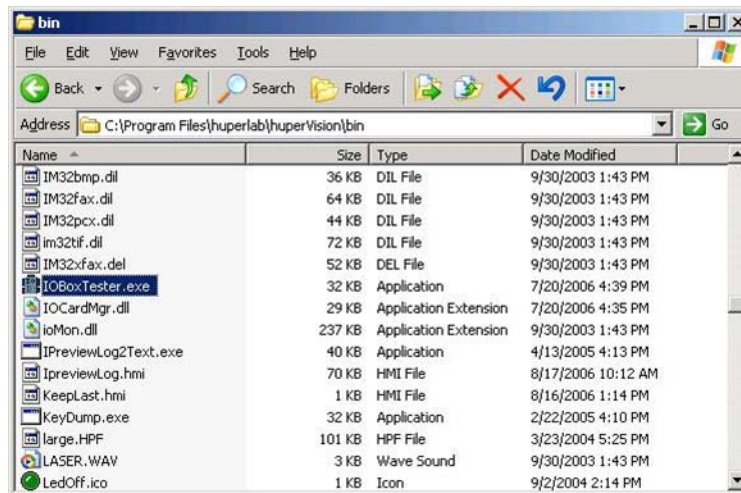

3. Double-click to run IOBoxTester.exe, then click the Scan button (see below).

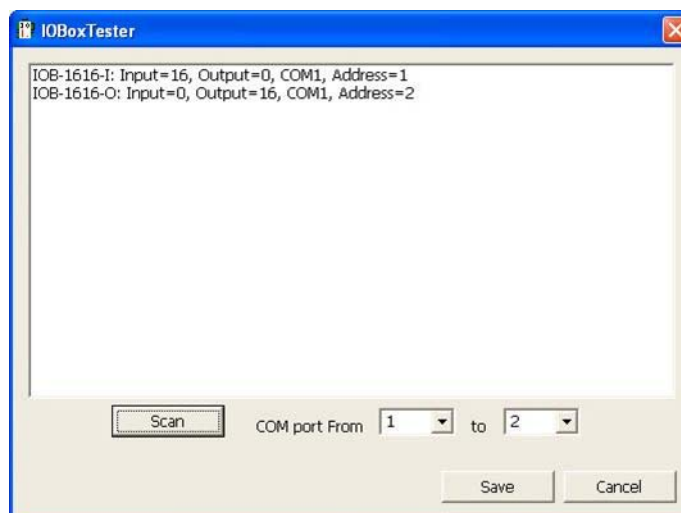

4. After the scan is completed, click the Save button.
5. After you restart the DVR site server. IO Box will be detected by the DVR in the Device tab of the Preferences dialog box.

Input Settings

- Step 1: Open the Preferences dialog box, then click the Device/Input tab.
- Step 2: Select the item "IOB-1616-I(1)" from the drop-down list.
- Step 3: 8 input ports are then displayed, and their assigned numbers start from 1 to 16.

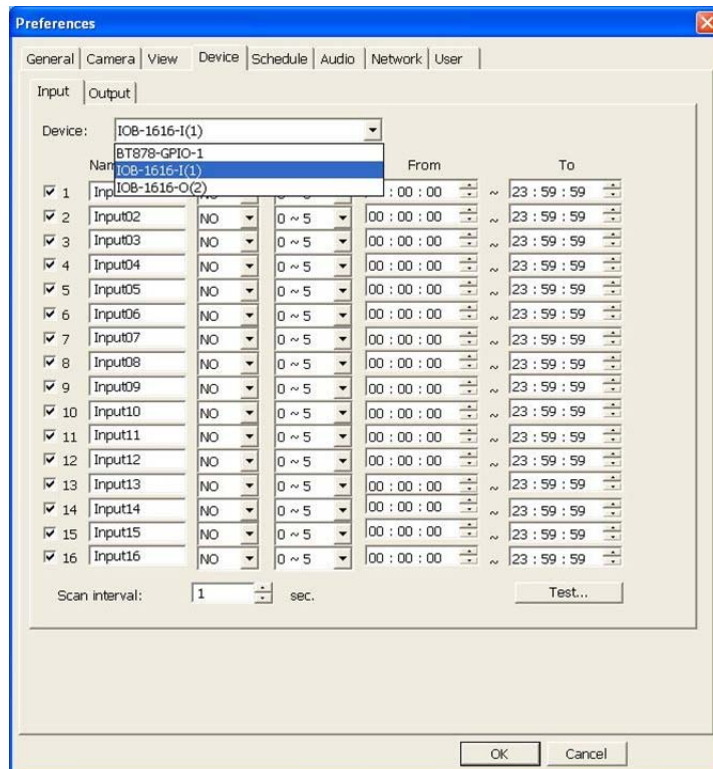

output Settings

- Step 1: Open the Preferences dialog box, then click the Device/Output tab.
- Step 2: Select the item "IOB-1616-O(2)" from the drop-down list.
- Step 3: 8 input ports are then displayed, and their assigned numbers start from 1 to 16.

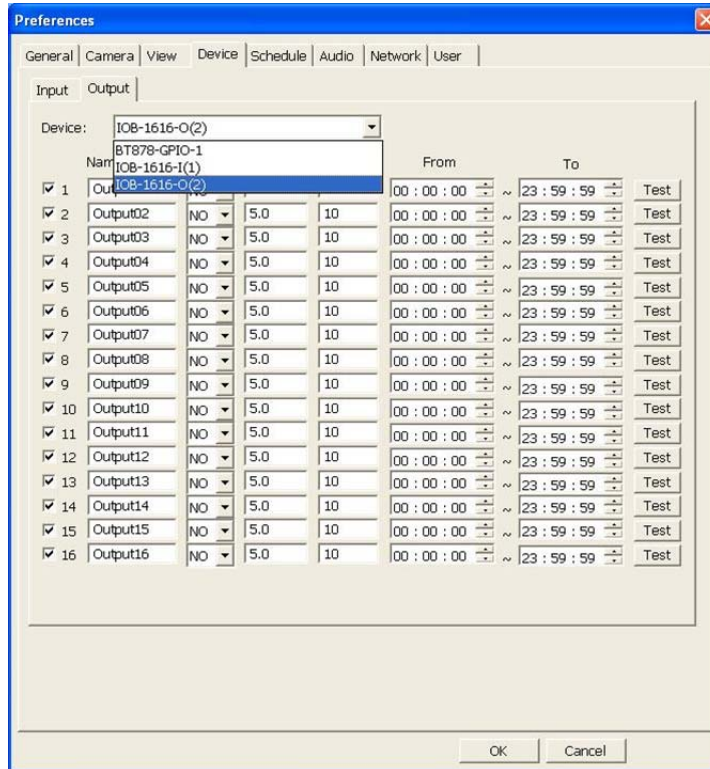

Appendix 8

LB-16 Input Video Loopback

Video loop back card connects to huperVision capture cards to loop back video signals. Camera video can through the video loop back card to the monitor set or to the quad processor for monitoring purpose or other special applications.

Specifications

Model name	LB-16 (AD043)
System	32 bits 5V PCI card
Video Input	Four center crimp terminal housing up to 16 channel video input One box header (2*13 pin) support 16 channel video input Two box header (2*13 pin) support 8 channel video input
Video Output	D-sub 25 connector support 16 channel video output
Video signal	1 Vpp, 75Ω switch
Dimension	119.88*85.09 mm

Connector Pin Assignment

- Center crimp terminal housing for 4 channel video input (CN1,2,3,4)

Pin no.(CN1)	Signal	Pin no. (CN1)	Signal
1	X	4	Video 3
2	Ground	5	Video 2
3	Video 4	6	Video 1

Pin no.(CN2)	Signal	Pin no. (CN2)	Signal
1	X	4	Video 7
2	Ground	5	Video 6
3	Video	6	Video 5

Pin no.(CN3)	Signal	Pin no. (CN3)	Signal
1	X	4	Video 11
2	Ground	5	Video 10
3	Video 12	6	Video 9

Pin no.(CN4)	Signal	Pin no. (CN4)	Signal
1	X	4	Video 15
2	Ground	5	Video 14
3	Video 16	6	Video 13

2. Box header for 16 channel video input (P1)



Pin no.(P1)	Signal	Pin no.(P1)	Signal
1	Video 1	14	Ground
2	Video 14	15	Video 8
3	Video 2	16	Ground
4	Video 15	17	Video 9
5	Video 3	18	Ground
6	Video 16	19	Video 10
7	Video 4	20	Ground
8	Ground	21	Video 11
9	Video 5	22	Ground
10	Ground	23	Video 12
11	Video 6	24	Ground
12	Ground	25	Video 13
13	Video 7	26	Ground

3. Box header for 8 channel video input (P2)

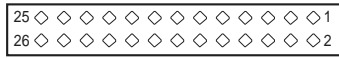

Pin no.(P2)	Signal	Pin no.(P2)	Signal
1	Video 1	14	Ground
2	X	15	Video 8
3	Video 2	16	Ground
4	X	17	X
5	Video 3	18	Ground
6	X	19	X
7	Video 4	20	Ground
8	Ground	21	X
9	Video 5	22	Ground
10	Ground	23	X
11	Video 6	24	Ground
12	Ground	25	X
13	Video 7	26	Grounds

4. Box header for 8 channel video input (P3)



Pin no.(P3)	Signal	Pin no.(P3)	Signal
1	Video 9	14	Ground
2	X	15	Video 16
3	Video 10	16	Ground
4	X	17	X
5	Video 11	18	Ground
6	X	19	X
7	Video 12	20	Ground
8	Ground	21	X
9	Video 13	22	Ground
10	Ground	23	X
11	Video 14	24	Ground
12	Ground	25	X
13	Video 15	26	Ground

5. D-sub 25 connector for 16 channel video output (P4)

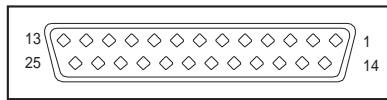

Pin no.(P4)	Signal	Pin no.(P4)	Signal
1	Ground	14	Video 1
2	Video 5	15	Ground
3	Video 9	16	Video 13
4	Ground	17	Video 2
5	Video 6	18	Ground
6	Video 10	19	Video 14
7	Ground	20	Video 3
8	Video 7	21	Ground
9	Video 11	22	Video 15
10	Ground	23	Video 4
11	Video 8	24	Ground
12	Video 12	25	Video 16
13	Ground		

6. Connect to video capture card

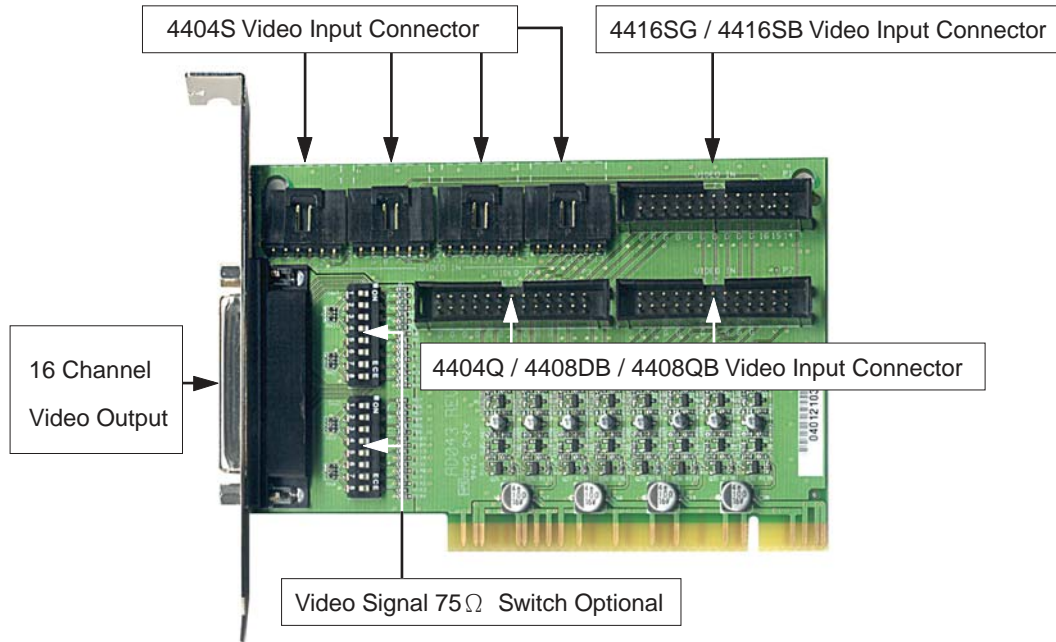

Capture Card Model / Max Number	Slots for connection	# of Loop Back Channels
4404S x 4	P4, P5, P6, P7	4, 8, 12, 16
4416SG x 1	P1	16
4416SB x 1	P1	16
4404Q x 2	P2, P3	4, 8
H4008DB x 2	P2, P3	8, 16
H8008DB x 2	P2, P3	8, 16

Appendix 9

PTZ Camera Auto-tracking Guide

System Requirements

1. A DVR machine with huperVision 4000 v1.2 installed.
2. A Pelco PTZ camera or a Messoa PTZ camera that supports the Pelco-D control protocol (plus an RS232/RS485 converter if the DVR machine doesn't provide an RS485 port.)

Installation

- Step 1: Make sure the PTZ camera device uses the Pelco-D control protocol. If not, please adjust its switcher or jumper to use Pelco-D protocol.
- Step 2: Connect the video cable of the PTZ camera to a BNC port of the capture card on the huperVision machine.
- Step 3: Connect the control cable of the PTZ camera to one COM port on the huperVision machine. If the huperVision machine doesn't support the RS485 port, an RS232/S485 convert is required.

Customize Settings

1. Connect the PTZ camera to the DVR system and define a preset position

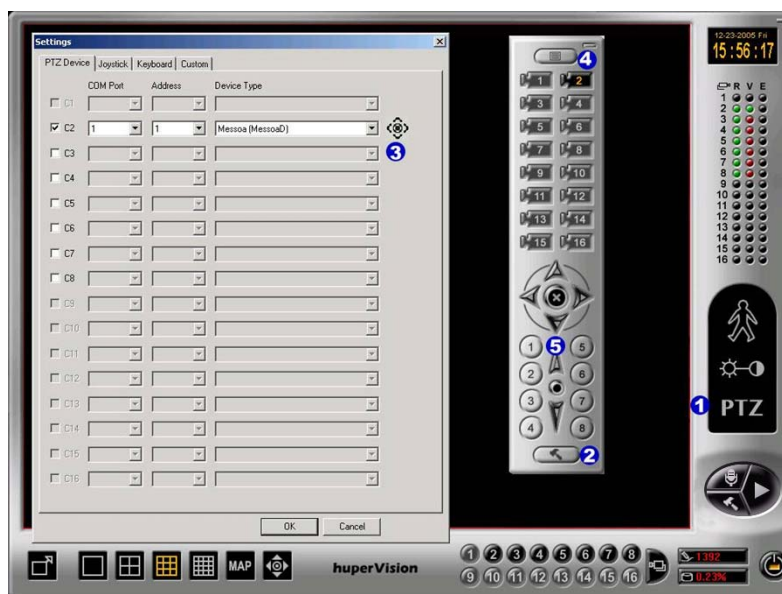

- Step 1: Click the “PTZ” icon on the panel at the right side of the huperVision system to display the PTZ Control Panel.
- Step 2: Click the hammer button at the bottom of PTZ Control Panel to open the “Settings” dialog box.
- Step 3: In the “Settings” dialog box, enter the PTZ camera information onto the “PTZ Device” setting page.
- Select the “Cx” check box where “x” indicates the channel number that the PTZ camera’s video cable connects to.
 - Select the COM port from the “COM port” list that the PTZ camera’s control cable connects to.
 - Select the address ID of the PTZ camera from the “Address” list (check the PTZ camera switcher to find the address ID or inquire from the dealer.)
 - From the “Device type” list, select “Messoa (MessoaD)” for the Messoa PTZ camera, or select “Pelco D, 2400 bps (Pelco-D)” for the Pelco PTZ camera.
 - Then click the “OK” button to close the “Settings” dialog box.
- Step 4: Click the camera button to select the PTZ camera.
- Step 5: Define a preset position where the PTZ camera will move to after tracking. First, adjust the camera viewing angle to an appropriate position. Then save the position to a preset button by pressing a preset button and holding it for about 3 seconds.

2. Enable the auto-tracking function and customize its settings.

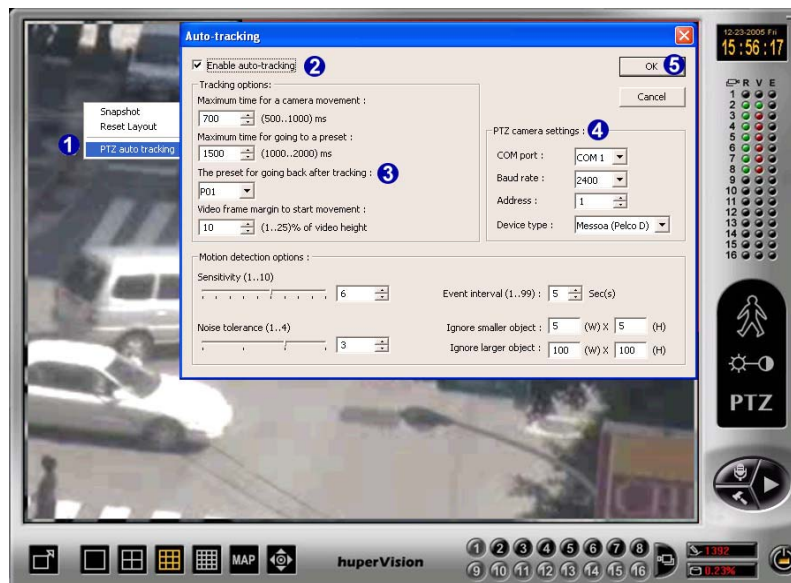

- Step 1: Right-click on the PTZ camera video to display a pop-up menu. Then click "PTZ Auto-tracking".
- Step 2: In the "Auto-tracking" dialog box, select the "Enable auto-tracking" checkbox to activate the auto-tracking function.
- Step 3: From "The preset for going back after tracking" list, select the preset position where the PTZ camera will move back to after tracking. Selecting "None" will make the PTZ camera stay at the last position after tracking.
- Step 4: Specify the PTZ camera information, including COM port, baud rate, address ID and device type. The suggested baud rate is 2400 for the Messoa PTZ camera and Pelco PTZ camera.
- Step 5: Click "OK" to confirm the settings and start the auto-tracking function.

Auto-tracking Settings

The following are the settings you can adjust in the Auto-tracking dialog box to optimize the accuracy of auto-tracking:

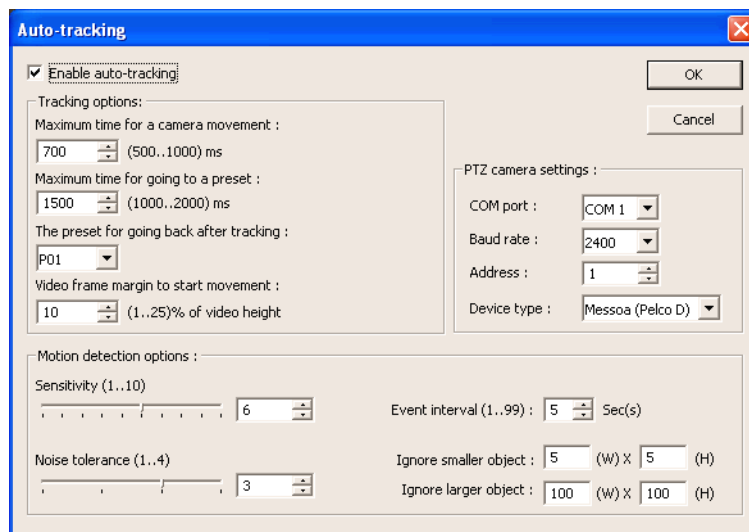

- 1 **Enable auto-tracking** Select this checkbox to activate the auto-tracking function.

Note: While auto-tracking is enabled, you cannot manually control the PTZ camera on the PTZ Control Panel.

- 2** Maximum time for a camera movement Specify the maximum time for the PTZ camera to complete a movement. While PTZ camera is in movement, motion detection will be disabled. After it completes the movement, motion detection will be enabled automatically. The time duration can be set anywhere between 1000 to 2000 ms.
- 3** Maximum time for going to a preset Specify the maximum time for the PTZ camera to move to a preset position. An appropriate time is the period for the PTZ camera to complete a movement along a circumference. The time duration can be set anywhere between 1000 to 2000 ms.

Note: If the specified time for moving to a preset is too short to complete a movement, the auto-tracking function may not work accurately.

- 4** The preset for going back after tracking Select the preset position where the PTZ camera will move back after tracking. Select None if you want the PTZ camera to stay at the last viewing angle and position.
- 5** Video frame margin to start movement Define the frame margin in the PTZ camera video. The PTZ camera will not move until moving objects touch the frame. The frame width can be set between 1% to 25% of the video height.
- 6** PTZ camera settings Set the COM port, Baud rate, Address, and Device type.
- COM port Select the COM port number that the control cable of the PTZ camera connects to.
 - Baud rate Select the appropriate baud rate to define the communication speed between the huperVision system and the PTZ camera.

- **Address** The address of the PTZ camera is defined by the PTZ camera device's ID switcher and jumper. If you find no address ID or have no idea about it, try selecting a value of 1. If it doesn't work, please contact your dealer to get a correct address ID.
- **Device type** There are two available device types: Messoa (Pelco D) for the Messoa PTZ camera, and Pelco (Peloc D) for the Pelco PTZ camera.

Note: Please be sure to set the correct COM port, baud rate and address ID. Otherwise, the auto-tracking function will not work.

- 7** **Sensitivity** Specify the sensitivity level of motion detection. The sensitivity level can range from 1 to 10.
- 8** **Noise tolerance** Specify the tolerance level to camera video noise. This can range from 1 to 4.
- 9** **Event interval** Specify the minimum interval between tracking events. If the specified interval has elapsed and there are still no objects tracked, the PTZ camera will return to the selected preset position (or it will stay at the last position if None has been selected under The preset for going back after tracking option).
- 10** **Ignore smaller / larger objects** Specify the size of moving objects that will be ignored during tracking.

Appendix 10

ATI & Nvidia Dual-screen setting

ATI Dual-screen setting

1. Download Drivers & Software from <http://www.ati.com>

- (1) Microsoft .NET Framework
- (2) Catalyst Control Center Package

Catalyst Component	Download Link	File Size (KB/MB)	Date Posted	Additional Info and components
Microsoft .NET Framework	Download 1 of 3	22.4	04/06/06	This is a required download.
Catalyst Control Center Package	Download 2 of 3	34.2	04/12/06	Display and WDM Drivers included in this bundle

2. Install Microsoft .NET Framework.
3. Install VGA driver.
4. Setup ATI-multimoniter
 - (1) Right-click you mouse on the Windows desktop.
 - (2) Select ATI Catalyst Control.

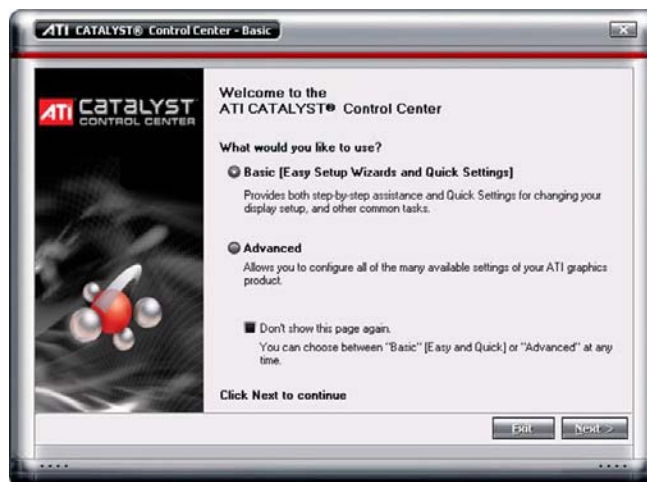

(3) Click the Next button.

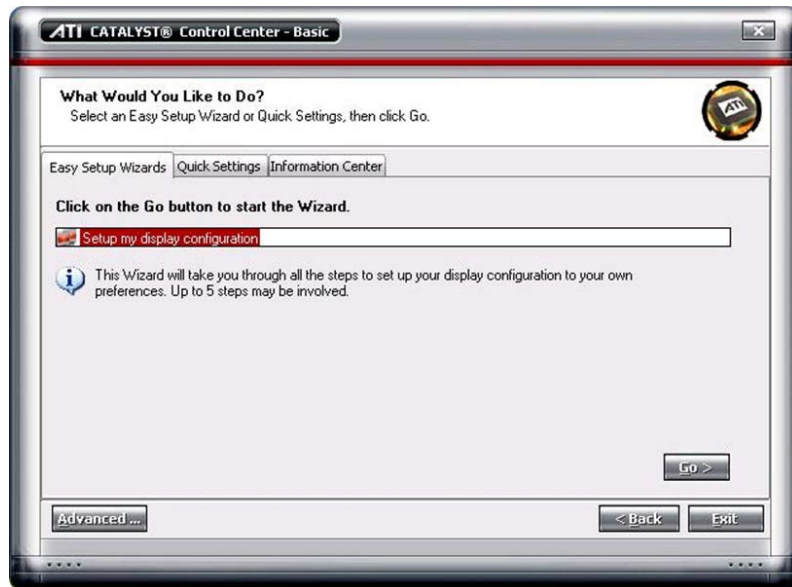

(4) Click the Go button.

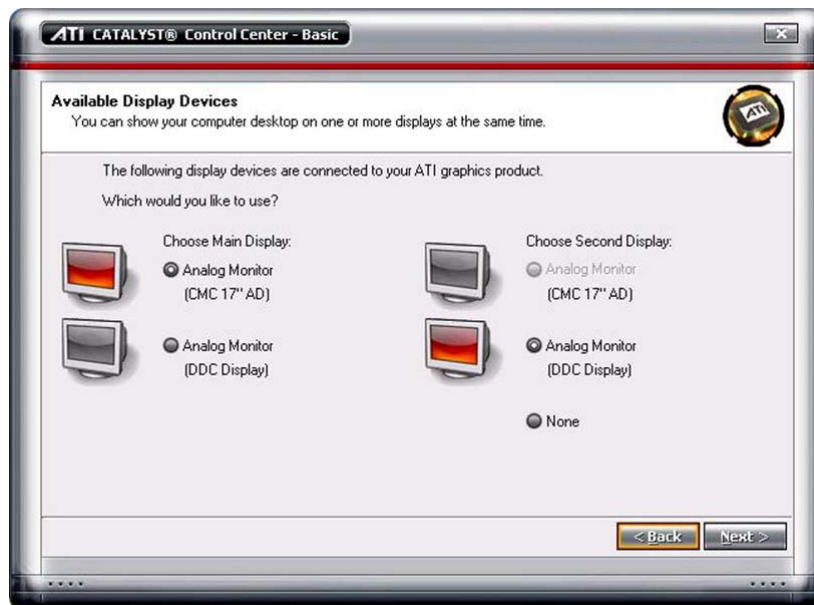

- (5) Select your desired choice, and click Next

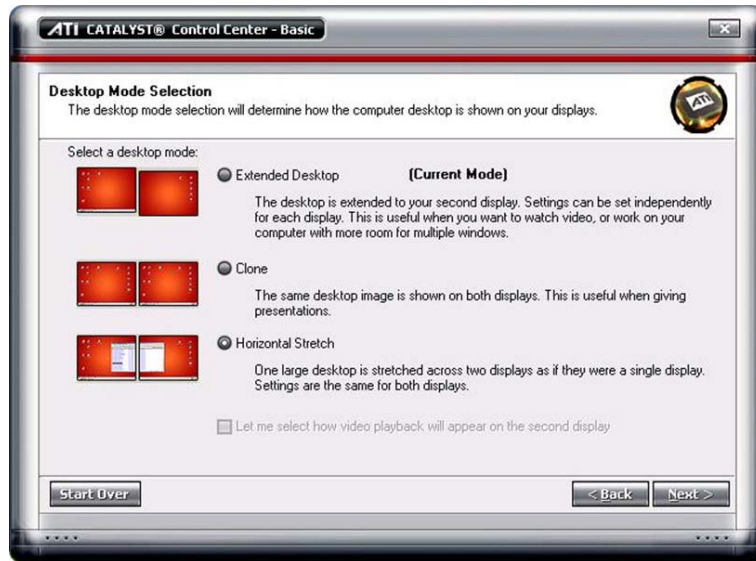

- (6) Select "Horizontal Stretch" and click the Next button.

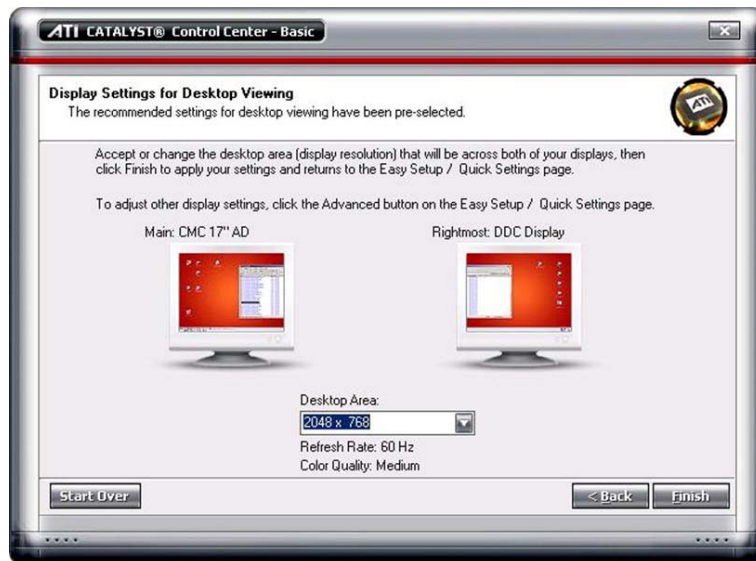

(7) Click the Finish button.

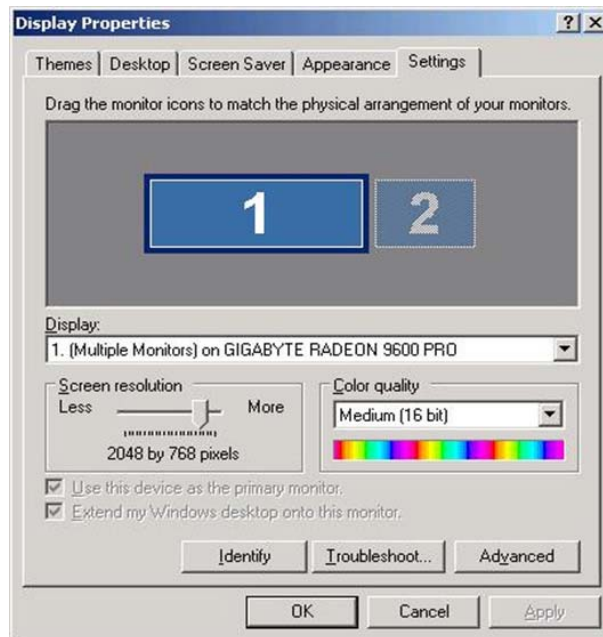

(8) Check "Display Properties" 2048*768", "16bit".

Nvidia GeForce 6600 Dual-screen setting

Step1:



Step2:

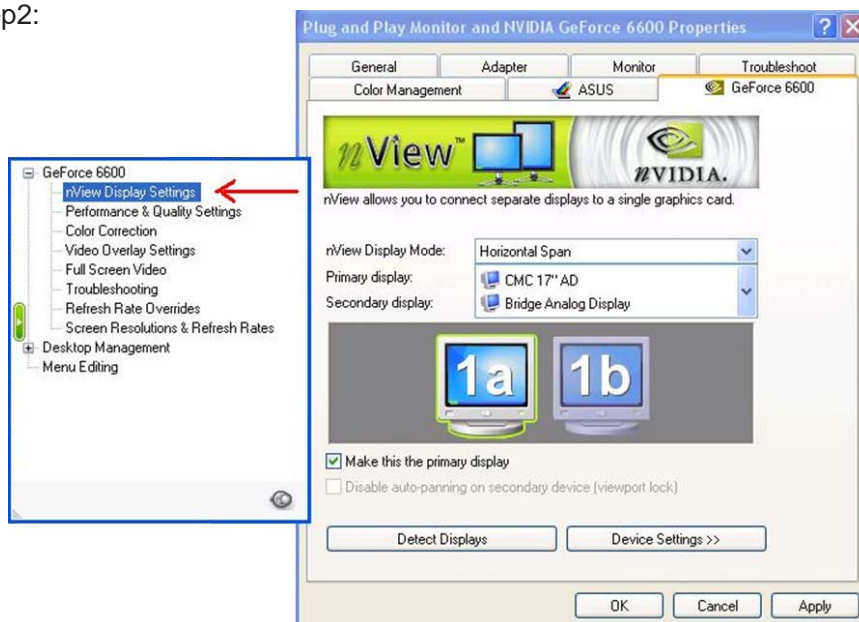

Step3:

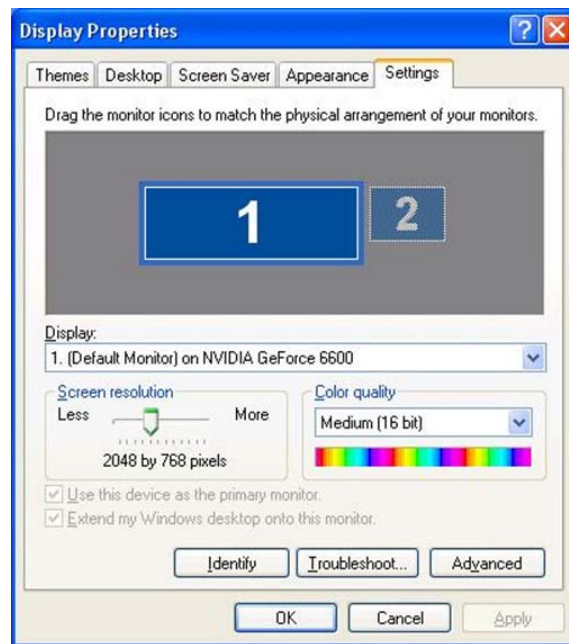

Step4:



Appendix 11

People Counter User Guide

Feature

Calculate amount of passing passengers within assigned detection area. Counting direction could be leftward/rightward or upward/downward according to the position of detection area.

Environment Setup

Camera should mount above the detection area and capture video downward vertically as the picture below. Favorite object size should occupy around the tenth of video window. Improper object size (too large or too small) or tilted camera angle may affect the counting result.

Detection area could locate in the top, bottom, left, right or center of the video window. It will calculate upward and downward people flow if the detection area is located at top or bottom position. Calculate leftward/rightward flow for left or right position. Counting direction will depend on the width/height ratio if the detection area is in the center position.

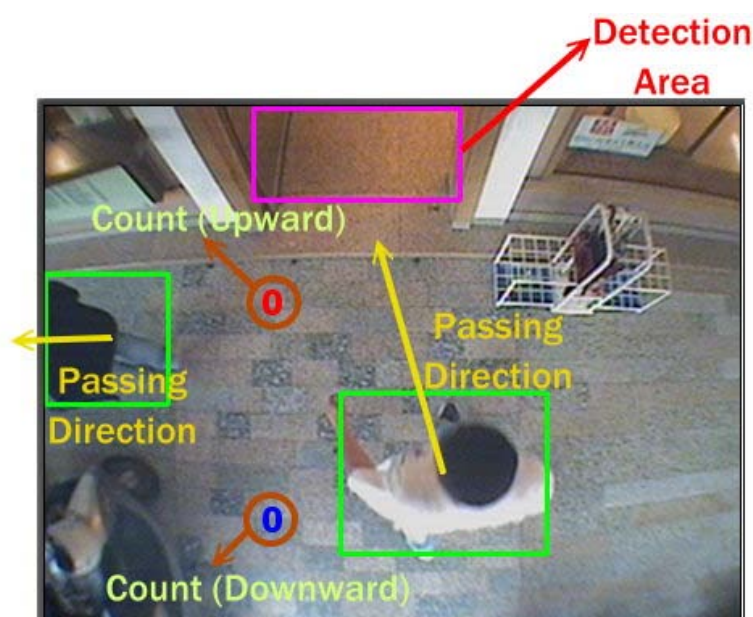

Please DO NOT setup system under the environments below to avoid incorrect detection result:

- Interference of open/close door
- Intensively light variation or shadow area under sunshine
- Sheltered object
- Shaking camera
- Crowded location
- Unstable background (like wavered leaves)

Setup Procedures

Open Settings to setup detection options:

Setting Detection Area

Press Open Drawing Panel button to pop-up drawing control panel and then draw detection area. Only one detection area could be set which can be located at any side or center of the video window.

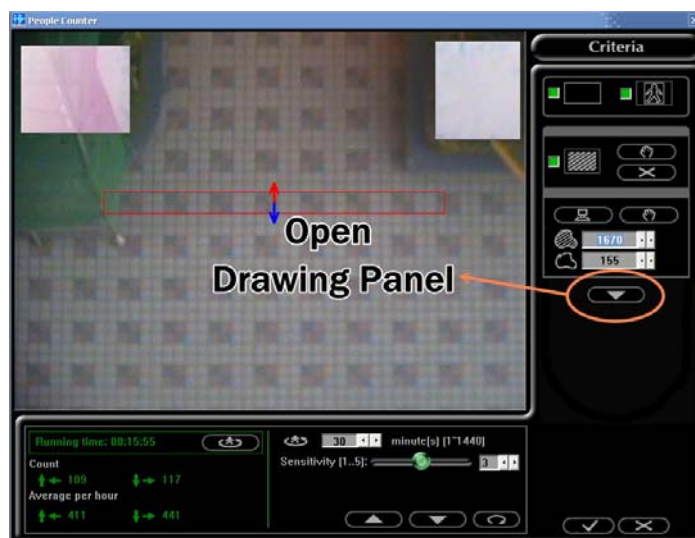

Locate at one of the four position as below (should not be too long or too thin to avoid incorrect result), for example. This configuration is used for camera mounted at the top of arcade to calculate people flow without entering door.



Or locate at center (proper size with long and thin shape is OK) as picture below:

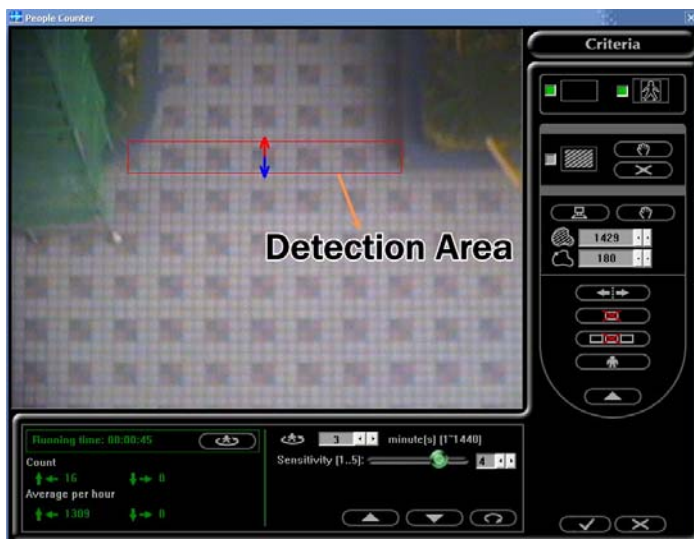

Notice: If the detection area is located at top (bottom) position with slender shape (length is much larger than width) as picture below, the counting direction will be leftward/rightward. The same case for tall and thin shape located at left (right) position, the counting direction is upward/downward.



After drawing detection area, the program will determine the detection location and counting direction automatically. To calculate single direction flow, press the Set Counting Direction button in the drawing control panel.

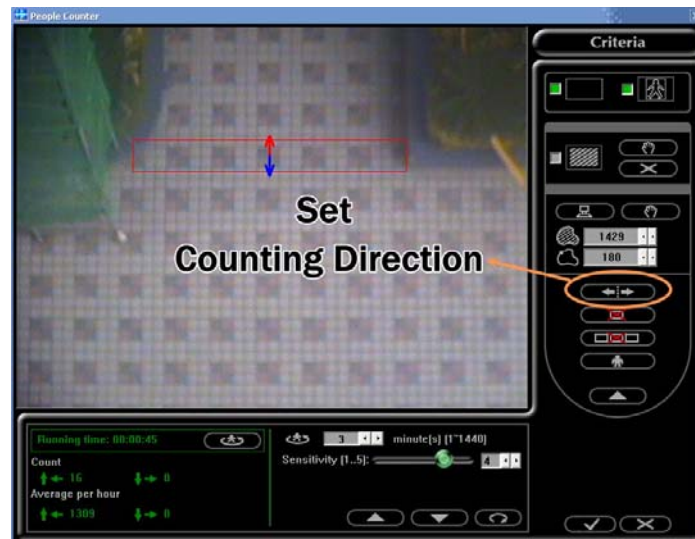

It needs to delete original detection frame to change the position of detection area (it only allows one detection area now),



Setting Single Person Size

Due to various camera mounting situations, it needs to adjust single person size after setting detection area. There are three ways to set single person size:

Method 1: Input setting parameters directly. Parameter 1 is pixel amount and parameter 2 is contour length. Suggest using method 2 or 3 if not familiar with parameter definition. Parameter 1 is 1430 and parameter 2 is 180 for the case below.

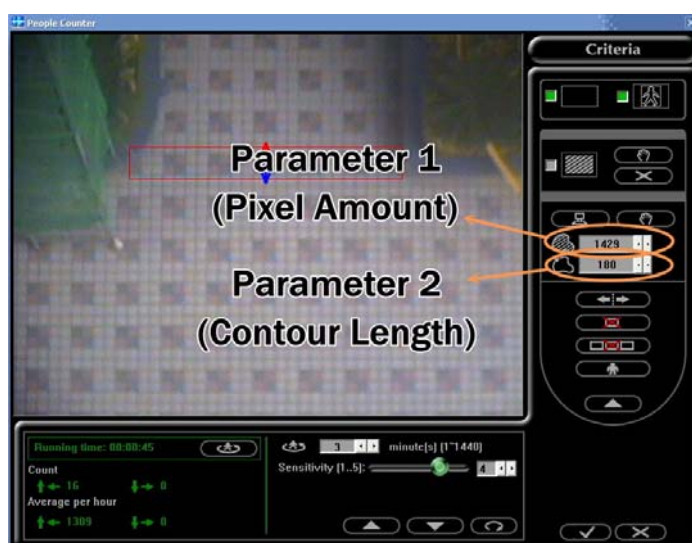

Method 2: Set single person size manually. Follow the steps below.

1. Press Set Single Person Size Manually button in the drawing control panel.



2. Drag rectangle in the window. Suggest pausing video when there is a passenger. Then drag rectangle according to this object. It will calculate the parameters automatically after drawing.



Method 3: Get single person size automatically. Follow the steps below.

1. Press Get Single Person Size Automatically button in the drawing control panel.



2. Program will calculate average single person size parameters according to the current people flow.

Notice: It is necessary to adjust sensitivity to get accurate segmentation because each segmented object will be treated as single person. Reduce sensitivity if shadow or noise is easily segmented as object. Increase sensitivity if one person is segmented into several objects or can not be segmented.

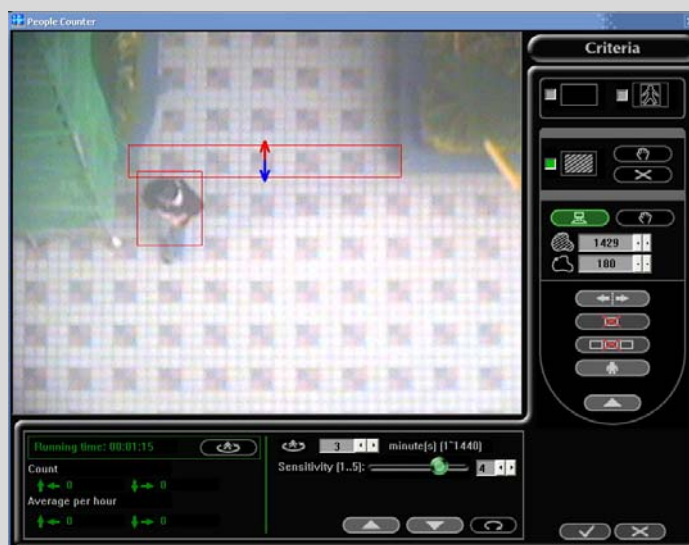

3. Press Get Single Person Size Automatically button again to end calculation and reflect result in the single person size parameter setting area (the parameters are not changed if there is no segmented object during calculation period).

Tuning Parameters:

Start calculating people flow after setting options. Using tuning function to adjust detection parameters if there is overcount or undercount situation. Press Overcount button to increase parameters in overcount case; press Undercount button to decrease parameters in undercount case.



Start counting:

Program can start calculating people flow after drawing detection area & setting single person size. It will capture background first. The counting is started under the following condition:

- Scene without change for several frames
- After a couple of seconds

The program is starting calculating when the video window appears detection frame and counting numbers. It will update background information continuously during calculation. Objects remaining static within video window for a couple of time will be merged as background information.

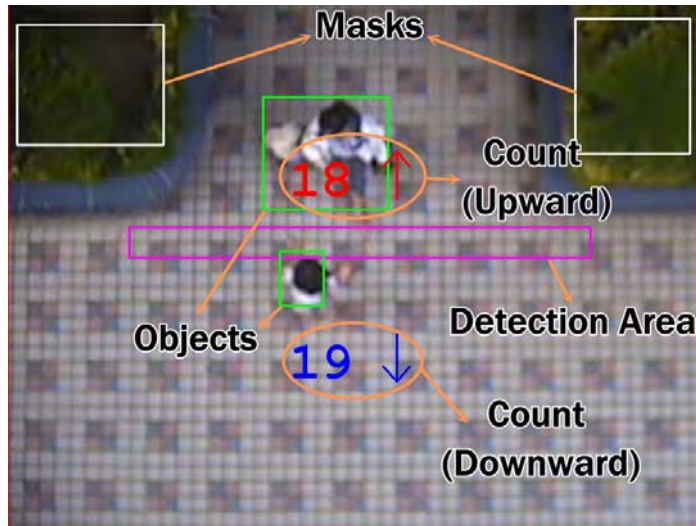

Calculating condition when detection area located in the border of video window (This detection condition is more strictly, suitable for arcade to calculate people flow without entering door.):

IN	Coming from the edge of window & entering partial detection area
OUT	Going through detection & touching the edge of window

Calculating condition when detection area located in the center of video window (suitable for passage or door with passengers):

Upward (Rightward)	Moving from bottom (left) side, passing through detection area, to top (right) side
Downward (Leftward)	Moving from top (right) side, passing through detection area, to bottom (left) side

Feature Description



Time from starting to now. It will reset the running time after a statistics period and export calculation result to log file.



Reset counting process. Program will export previous calculation result to log file, capture new background information and restart counting.



Counting number after starting (Up/Left, Down/Right)



Average passengers per hour (Up/Left, Down/Right)



Time for counting cycle. Program will reset counting process and export result to log file when finishing counting a cycle.



Object segmentation sensitivity (1~5, larger number means more sensitive) Reduce sensitivity if shadow or noise is easily segmented as object. Increase sensitivity if one person is segmented into several objects or can not be segmented.



Parameter tuning buttons with overcount/undercount case



Reset detection parameters to default values



Enable/disable display detection area frame



Enable/disable display object frame



Enable/disable mask related features



Set non-segmentation area. Up to 10 mask areas can be used. Use mask for unstable background (ex: leaves, flags) to avoid incorrect calculation. Mask area will display as negative image frame.



Remove all masks



Get single person size parameters automatically



Set single person size parameters manually



Open drawing control panel



Change counting direction



Remove detection area



Freeze current video display



Close drawing control panel

Appendix 12

An Example of IP Camera (Video Server) Network setting

Here we take EtroVision IP camera (video server) as an example.

Modify IP address of IP camera (video server)

1. Run EtroScan Utility that comes with EtroVision IP camera (video server).

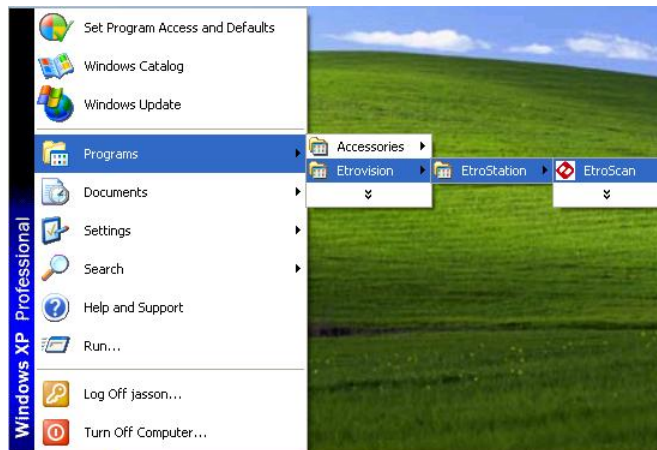

2. Scan the available IP cameras in the network. Modify the IP address to be located within the same sub network of your DVR site.

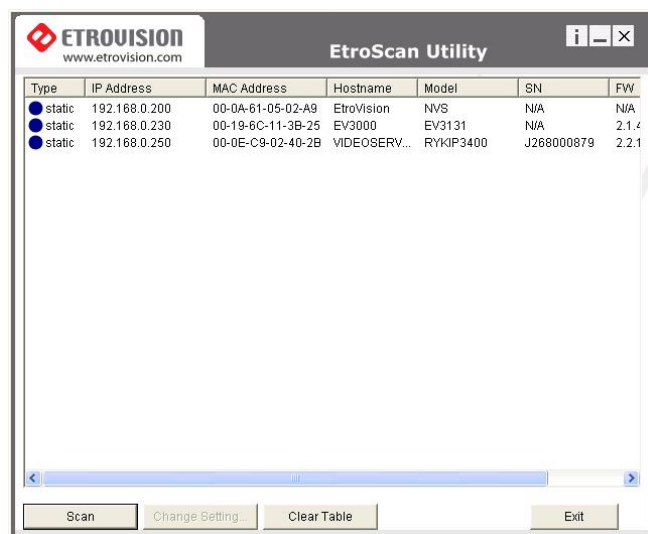

Edit IP Camera settings

Run web browser and enter IP address of IP camera to enter camera setting page. The default username/password combination for EtroVision IP camera is “root/pass”.

The screenshot shows the EtroVision EV3000 Video Server web interface. The top left corner features the EtroVision logo and the website URL www.etrovision.com. The top right corner displays "EV3000 Video Server" with a small icon. A left-hand navigation menu is visible, with "Video" selected under the "Basic" category. The main content area is titled "Video" and contains a "Video Setting" section with the following fields:

Video Compression Type	MPEG4
Resolution	D1
Frame Type	IP Only
Bitrate Type	<input checked="" type="radio"/> Constant Bitrate <input type="radio"/> Variable Bitrate
	1M
Frame Per Sec	30
GOP Size	60
Video Field Type	<input checked="" type="radio"/> NTSC <input type="radio"/> PAL <input type="button" value="Detect"/>

PTZ Control settings

Control PTZ camera through video sever, follow the steps below:

1. Switch to PTZ Control page.
2. Select Transparent from Channel Model (PTZ Model).
3. Reboot the video server.

The screenshot shows the EtroVision EV3000 Video Server web interface with the "PTZ Control" page selected. The left-hand navigation menu is visible, with "PTZ Control" selected under the "Expert" category. The main content area is titled "PTZ Control" and contains a "Channel 1" section with the following fields:

Channel Model (PTZ Model)	Transparent
Channel ID(Rx Address)	1
Baud Rate	B2400
Data Bits	8
Parity	none
Stop Bits	1

Note: You must use set ID/PW to connect the Video Server in huperVision site server.

Connect Multiple IP Cameras under NAT

Follow the steps below to connect IP cameras under NAT (firewall):

1. Change the A/V Port of video server from default 1852 to other actually available port number under this NAT (ex: 11852).

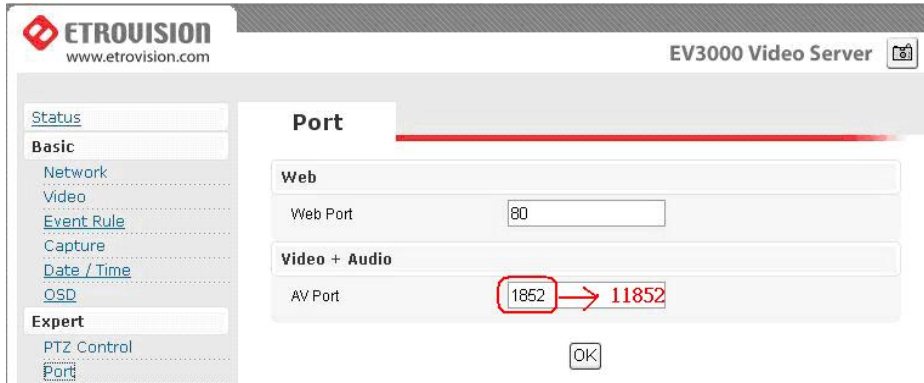

2. Choose an available port of NAT (e.g. 5180) and forward it to the default port (HTTP Port) of video server (here we use EtroVision 151 as an example).

NAT >> Configure Port Redirection Table

#	Mode	Service Name	Protocol	Public Port	Private IP	Private Port	Active
1	Single	IP Camera	TCP	4242	192.168.0.115	80	<input checked="" type="checkbox"/>
2	Single	IP Camera 2	TCP	4243	192.168.0.106	80	<input checked="" type="checkbox"/>
3	Single	Hunt	---	18089	192.168.0.105	80	<input type="checkbox"/>
4	Single	Jacky ACTi	---	6002	192.168.0.130	6002	<input type="checkbox"/>
5	Single	Jacky1	TCP	18088	192.168.0.135	18088	<input checked="" type="checkbox"/>
6	Single	Jacky2	TCP	18090	192.168.0.108	18088	<input checked="" type="checkbox"/>
7	Single	Jacky ACTi	TCP	1830	192.168.0.130	80	<input checked="" type="checkbox"/>
8	Single	EtroVSCmdPort	TCP	5280	192.168.0.152	80	<input checked="" type="checkbox"/>
9	Single	EtroVSCmdPort	---	39109	192.168.0.151	39109	<input type="checkbox"/>
10	Single	EtroVSCmdhtPo	TCP	5180	192.168.0.151	80	<input checked="" type="checkbox"/>

3. Then, assign the NAT open port with the new A/V Port (e.g. 11852).

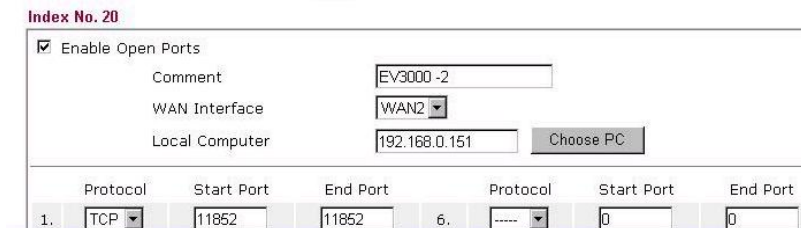

4. In the huperVision Site Server, add new IP camera with the IP Address of NAT and the corresponding port (5180) which has been forward to HTTP port of video server. Leave the Camera Model to [Auto detect].

Network setting
IP address: huperlab.com
HTTP Port: 5180

Account setting
Account: root
Password: ****
 Anonymous

Camera information
Camera model: ---- Auto detect ----
Description:

Advance setting
Connect...

OK Cancel

5. After making the settings, you can find the correct model of Video Server in the IP camera list.

IP camera list

IP Address	Camera model	Description	Status
192.168.0.103:80	HUNT - HLC-811		
192.168.0.104:80	HUNT - HLT-86F		
192.168.0.130:80	ACTI - ACD2100		
192.168.0.118:80	ACTI - ACD2100		
*192.168.0.146:80	ACTI - ACD2100		
192.168.0.132:80	ACTI - ACD2100		
192.168.0.106:5106	VIVOTEK - PT31x4		
192.168.0.138:5118	VIVOTEK - VS2101		
*192.168.0.07:90	AXIS - AXIS 211		
huperlab.com:5180	Etrovision - EV3000		

Add... Delete Modify... Search Refresh status

OK Cancel



You can use the same steps to connect multiple IP cameras under this NAT.

Appendix 13

Face Detection





Face Detection can detect human faces and log them in the surveillance video. Security personnel will be able to find out who entered/left the entrance of restricted areas and what time. The system will also alarm if a human face is detected in the forbidden area.



Follow these steps to mark areas and set up Face detection:

1. Open the Preferences dialog box and click the Camera tab.
2. Select a camera for which you want to set up Face detection by clicking its camera number.
3. In the Detect events by group box, select the Face detection checkbox, then click the Settings button. The Face Detection dialog box appears.
4. Click  to expand the drawing panel and reveal the complete button controls for setting up areas to be monitored.
5. Click  to temporarily freeze the live video and make it easier for you to mark areas on video.
6. Click a starting point on the video, drag your mouse to draw a rectangular box, and then release the mouse when you have completely boxed the area. After drawing a box, it is by default selected and appears in orange.
7. Use the other controls in the dialog box to modify detection settings. For more settings details, please see the section below.
8. Click the Apply button  to apply the detection settings to the chosen camera.

Face detection controls and settings



- 1** Show detected area  Select this option to display detected area (i.e., a rectangle) on the areas that will be the detection area.
- 2** Show tracking block  Select this option to display a tracking box around the faces that have been detected to have entered or occupied the forbidden areas.
- 3** Delete detection area  Click this button if you want to remove detection area and start all over.
- 4** Freeze Video  Click this button to freeze the live video.
- 5** Close drawing panel  Click this button to close the drawing panel.



- | | | |
|---------------------------------------|---|---|
| 6 Sensitivity | | Set the level of sensitivity (1~3). Low sensitivity means faster detection speed with higher error rate. High sensitivity means slower detection speed with lower error rate. |
| 7 Shortest event duration | | Set the minimum time duration (0~1000 ms) for each event. |
| 8 Event interval | | Specify the minimum interval (1~5 sec) between events. |
| 9 Ignore smaller/larger object | | Select this option to filter out small / larger objects whose dimensions are smaller / larger than a specific size. Suggest set these options to increase the detection accuracy. |
| 10 Reset |  | Click to load back the default settings. |
| 11 Apply |  | Click to apply the modified settings. |
| 12 Cancel |  | Click this button if you change your mind and do not want to apply the modified settings. The Face detection dialog box then closes and reuses the previous settings. |

Appendix 14

Scene Change Detection

Scene Change Detection will trigger alarms when the camera lens is covered, sprayed, out of focus, or the camera is repositioned.







Follow these steps to mark areas and set up Scene change detection:

1. Open the Preferences dialog box and click the Camera tab.
2. Select a camera for which you want to set up Scene change detection by clicking its camera number.
3. In the Detect events by group box, select the Scene change detection checkbox, then click the Settings button. The Scene Change Detection dialog box appears.
4. Click  to expand the drawing panel and reveal the complete button controls for setting up areas to be monitored.
5. Check the Show Status Cue bar to display Scene Change Status Block on live video. The default Purple color means no scene change alarm. Orange color block means detected a scene change event and alarm.
6. Use the other controls in the dialog box to modify detection settings. For more settings details, please see the section below.
7. Click the Apply button  to apply the detection settings to the chosen camera.

Marking areas to exclude from detection

The first thing you need to do is to mask out irrelevant areas that will not be included in scene change detection. Click  to expand the Mask drawing Panel. This panel contains button controls which allow you to mask out areas that will be excluded from detection.



- | | | | |
|----------|-----------------------|---|--|
| 1 | Show mask |  | Select this option to display a mask (i.e., a shield) on the areas that will be excluded from detection. This option is disabled in this detection. |
| 2 | Show status cue block |  | Select this option to display a rectangular box on areas that have been detected with scene change. Display purple rectangle under detection status and change to orange rectangle when there is an event. |
| 3 | Add mask |  | Select this option to add a mask. Use the drawing tools to draw the mask. |
| 4 | Subtract mask |  | To add back parts from a masked-out area and include them during detection, select this option. Use the drawing tools to erase the mask. |
| 5 | Drawing tools | | Use one of the following drawing tools to draw masks: |
| | Rectangular mask |  | Select this tool to draw a rectangular-shaped mask. Drag your mouse over an area on the video to draw the mask. |
| | Elliptical mask |  | Select this tool to draw an elliptical -shaped mask. Drag your mouse over an area on the video to draw the mask. |

Draw by Brush



Select this tool to draw a freeform-shaped mask. Drag the slider to the right to have larger-size brush strokes, or drag to the left to have smaller-size strokes. To draw the mask, drag your mouse over an area on the video.

6 Mask All



Click this button to mask out the whole video and then switch to the Subtract-mask mode automatically.

7 Clear Masks



Click this button to erase all the masks and then switch to the Add-mask mode automatically.

8 Close Mask drawing Panel



Click to close the Mask drawing Panel.

Scene change detection settings

To customize motion detection settings, adjust the controls at the bottom of the Motion Detection dialog box.

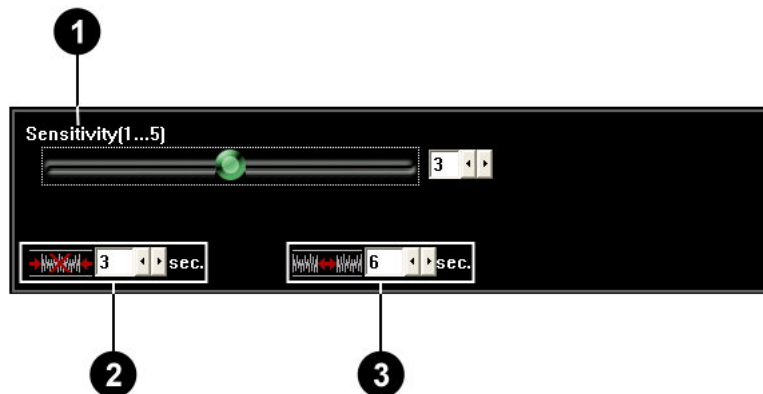

1 Sensitivity

Set the level of sensitivity to environment change. Low sensitivity means that minimal change will be ignored, and that only dramatic changes in background will be detected. High sensitivity means that even the smallest changes will be detected, but it could be a false event. Careful testing and fine tuning of the sensitivity setting is recommended.

- 2** Shortest event duration Set the minimum time duration for each event. If the duration of a detected event is shorter than the defined shortest event duration, it will not be treated as an event.

- 3** Event interval Specify the minimum interval between background change events.

Appendix 15

Flame Detection Pro

Flame detection pro added specific camera support that can increase detection precision. By adjusting the values of gain control and light control, you can get more accurate result with Flame detection pro.

To apply Flame detection pro, select the "Flame detection pro" option under the Detect events by group box in the Camera tab of the Preferences dialog box, then click the Settings button to open the Flame Detection Pro dialog box where you can set up how to detect for flames or flame- like flashes.





The Flame Detection Pro dialog box



- 1 Show yellow tracking block



Select this option to display a yellow frame around suspected flames or flame-like flashes.

- | | | | |
|-----------|-------------------------|---|--|
| 2 | Show tracking block |  | Select this option to display a red frame box around areas or objects that have been identified to be burning in flames. |
| 3 | Expand drawing panel |  | Click this button to expand the Mask-drawing Panel. This panel contains button controls which allow you to mask out to irrelevant areas that will not be included in the detection process. (These button controls are similar to the ones in the Motion Detection dialog box. For more information, see "Marking areas to exclude from detection" earlier in this chapter.) |
| 4 | Shortest event duration | | Set the minimum time duration for each event. If the duration of a detected event is shorter than the defined shortest event duration, it will not be treated as an event. |
| 5 | Event interval | | Specify the minimum interval between events. |
| 6 | Noise tolerance | | Adjust the noise tolerance level to reduce false alarms caused by video noises. The higher the tolerance level is, the less the interference of video noises. However, the sensitivity level will be reduced as well. |
| 7 | Sensitivity | | Set the level of sensitivity to flames. The higher the sensitivity level is, the more sensitive the flame detection is. |
| 8 | Reset |  | Click this button to load back the default settings. |
| 9 | Apply |  | Click this button to apply the modified settings. |
| 10 | Cancel |  | Click this button if you change your mind and do not want to apply the modified settings. The Flame Detection dialog box then closes and reuses the previous settings. |

11 Camera type

Select camera type. Flame detection pro is the same as flame detection if user select "General" type (gain control and light control parameters are disabled).

12 Gain control

Adjust camera dynamic range to compensate for the lack of light and produce clearer/usable images in low-light conditions. In low-light conditions, the higher the gain level is, the clearer/brighter the image is. The signal noise also increases dramatically with higher gain value.

13 Light control

Adjust the camera shutter speed when suspicious object is detected.

14 Camera option



Display dialog of specific camera related options. For example, the camera options dialog for Mintron MTV is shown as below:

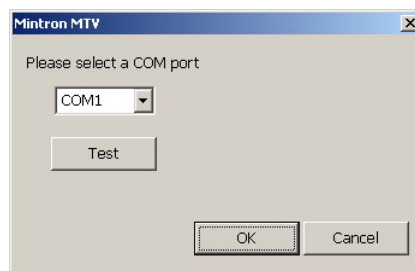

Appendix 16

HV Settings Import Export

HV Settings Import Export is a standalone tool to import/export environment settings of huperVision.. With this tool, you can setup DVR systems with predefined environment settings from other systems, or build up a standard DVR system settings for future usage.

Export settings

Follow these steps below to export settings from huperVision:

1. Run program HVSettingImportExport.exe and display the main windows as below



2. Click "Export" button to start export process.
3. Select the source (bin subfolder under the local HV system installed).
4. Select the destination folder and click "Export!!" button to start.

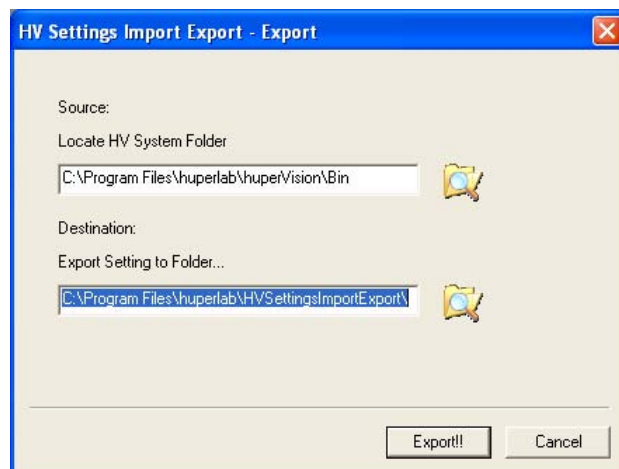

5. Click "OK" button to end and exit program.



The export process will export all the settings of current HV system and merge as a single folder.

Import settings

Follow these steps below to import settings to huperVision:

1. Run program HVSettingImportExport.exe and display the main windows as below



2. Click "Import" button to start import process.

3. Select source folder (where the exported HV system settings located) and destination folder (bin subfolder under the local HV system installed) then click "Import>>" button to next step.

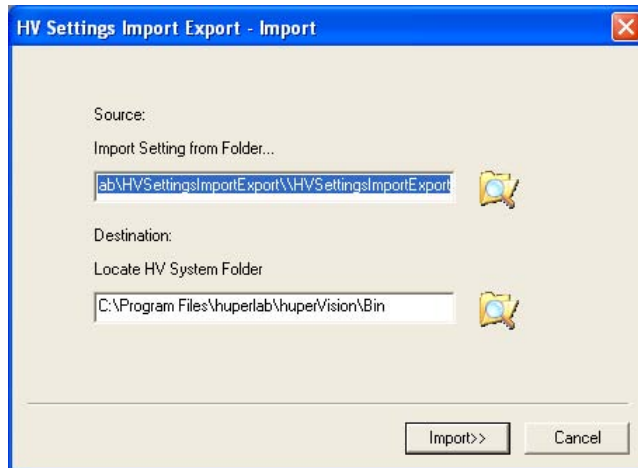

4. Select import parameters by check/uncheck options below. Click "More..." to adjust General/Camera sub options. If all the desired parameters are selected, click "Import>>" to start.





5. Click "OK" button to end and exit program.



Command Line Mode

Command line instructions for HVSettingsImportExport.exe:

```
HVSettingsImportExport Source Destination /ex /im
Source          Source folder
Destination     Destination folder
/ex             Export task
/im            Import task
```

The followings are the command line instructions examples.

To export settings:

```
HVSettingsImportExport c:\program
files\huperlab\huperVision\bin d:\backup /ex
```

To Import setting;

```
HVSettingsImportExport d:\backup c:\program
files\huperlab\huperVision\bin /im
```

Note.

1. The file HImportExportplugins.ini is the import option file which is generated by HVSettingsImportExport.exe under Windows mode.
2. To change import settings, you need to run the program in window mode and change import options. And then use command line mode to do the import task again.
3. Using command line instructions cannot modify the INI file.

Appendix 17

Web Remote Player

The Web Remote Player is a web page interface for users to remote playback video records on IE browser. In the Web Remote Player, Users can easily perform playback / download / snapshot video records from huperVision DVR site server.

Launch Web Remote Player

Please follow the instructions below to launch Web Remote Player.

1. Run the IE browser and input the IP address or URL address in the URL bar.



2. Connect to the DVR site and see the first page of Web Remote Viewer.



3. Press the  button to launch the Web Remote Player.



4. You will see the Web Remote Player launched in a new opened IE browser.

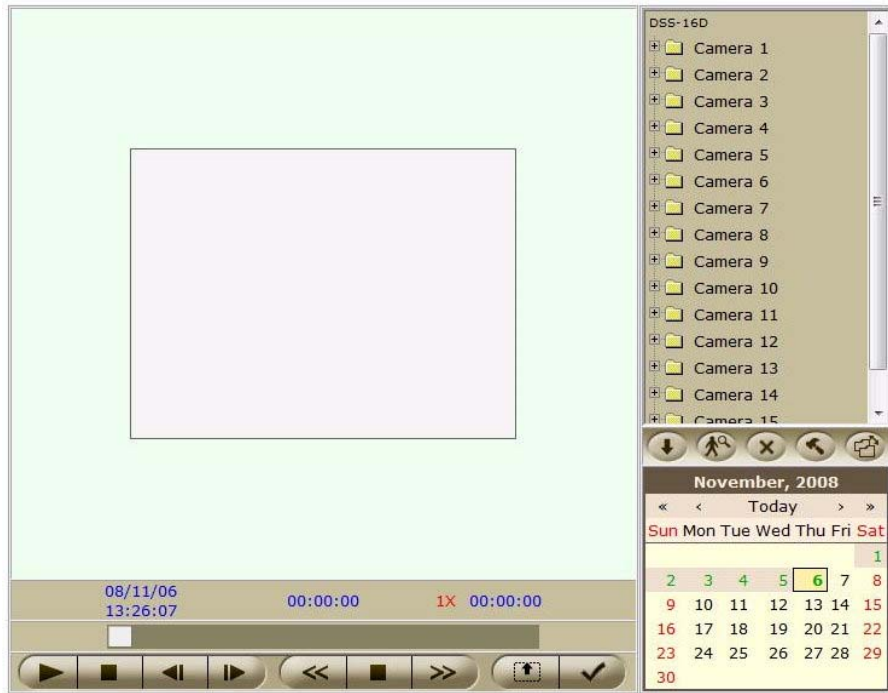

User Interface Areas

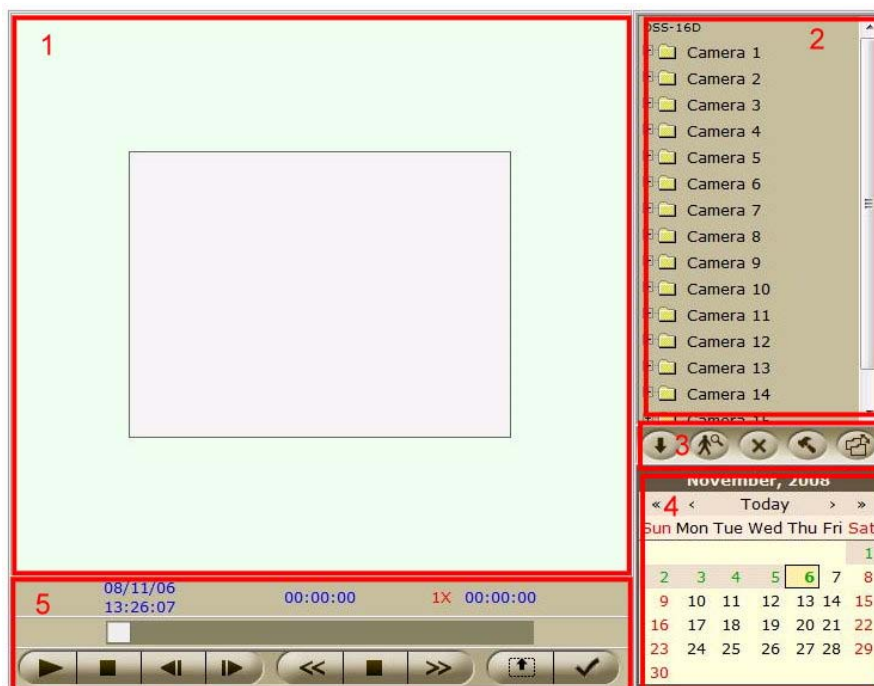

1. Video Display Area
2. Record List by Camera Area
3. Function Buttons Area
4. Calendar Area
5. Playback Control Area

Load and Playback Video Records

1. In the Record List Area, press the [+] mark to expend the list like below chart.
2. Select a time mark to playback.

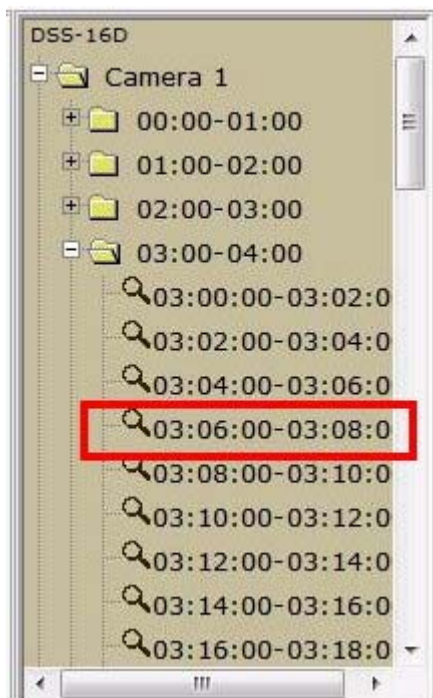

3. Press the Play Button to start playback.



Function Descriptions

Calendar





1. Press the Date to switch the Record List Result.
2. Press the [<] to Previous Month.
3. Press the [>] to Next Month.
4. Press the [<<] to Previous Year.
5. Press the [>>] to Next Year.
6. Press the [Today] to current date.









Playback Control



1. No. 1 is the current playback video clip start date & time.
2. No. 2 is the current frame time.
3. No. 3 is playback speed from 1/32X ~ 1X ~ 16X.
4. No. 4 is the current playback video clip end time.
5. No. 5 is the scroll bar for seeking the video clip

6.  Press this button to play video. This button will toggle to Pause button.



-  Press this button to pause video. This button will toggle to Play button.

7.  Press this button to stop.
8.  Press this button when video is paused to step backward 1 frame.
9.  Press this button when video is paused to step forward 1 frame.
10.  Press this button to reduce playback speed, down to 1/32X.
11.  Press this button to increase playback speed, up to 16X.
12.  Press this button to set playback speed to 1X.
13.  Press this button to enlarge the video, maximum to fill the video area.
14.  Press this button to snapshot the video.



In the snapshot mode, video will be paused and let you adjust brightness / contrast / saturation before save the snapshot into a image file.



Function Buttons

1.  Download selected video clip from DVR site server.
2.  Toggle between Normal Recording mode and Event Recordings mode.



3.  Delete selected video clip which has been downloaded.
4.  Settings from DVR sites connection parameters.



The image shows a dialog box for configuring DVR connection parameters. It contains the following fields and controls:

- IP/Domain Name : 192.168.0.149
- UserName : guest
- Password : *****
- Interval : 2
- Play Now
- Buttons: OK, Cancel

Please input DVR site IP/Domain Name, UserName(ID) and Password for connection.
The Interval parameter is for the camera list time interval.
Select Play Now to play video right after you selected a downloaded time frame.



5.  Connect to the DVR sites which been configured in Settings function.

Appendix 18

Privacy Mask

Privacy mask allows user to mask certain areas in the surveillance video for privacy protection.

Follow the steps below to setup Privacy Mask and create exclusive area:

1. Open the Preferences dialog box and click the Camera tab.
2. Select a camera for which you want to set up People counting by clicking its camera number.
3. In the Video settings group box, select the Video options checkbox, then click the Settings button. The Video options dialog box appears.
4. In the Video settings dialog box, select the Privacy mask checkbox, then click the Settings button. The Privacy mask dialog box appears.
5. Click  to expand the drawing panel and reveal the complete button controls for setting up detection area.
6. Click  to temporarily freeze the live video and make it easier for you to draw your detection area.
7. Click a starting point on the video, then drag your mouse to draw an exclusive area.
8. Click the Apply button  to apply mask areas to the chosen camera.

The Privacy Mask dialog box

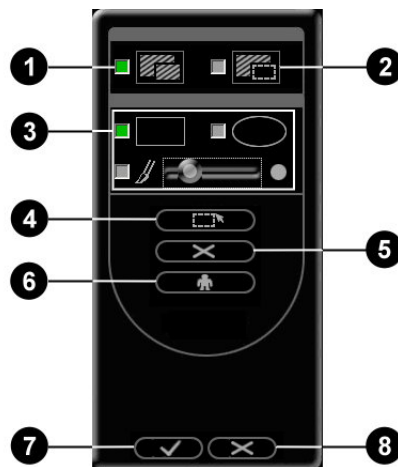

1 Add mask



Select this option to add a mask. Use the drawing tools to draw the mask.









2 Subtract mask



To add back parts from a masked-out area and include them during detection, select this option. Use the drawing tools to erase the mask.

3 Drawing tools

Use one of the following drawing tools to draw masks:

- | | | |
|-----------------------|---|---|
| Rectangular mask |  | Select this tool to draw a rectangular-shaped mask. Drag your mouse over an area on the video to draw the mask. |
| Elliptical mask |  | Select this tool to draw an elliptical -shaped mask. Drag your mouse over an area on the video to draw the mask. |
| Draw by Brush |  | Select this tool to draw a freeform-shaped mask. Drag the slider to the right to have larger-size brush strokes, or drag to the left to have smaller-size strokes. To draw the mask, drag your mouse over an area on the video. |
| 4 Mask All |  | Click this button to mask out the whole video and then switch to the Subtract-mask mode automatically. |
| 5 Clear Masks |  | Click this button to erase all the masks and then switch to the Add-mask mode automatically. |
| 6 Freeze Video |  | Click this button to freeze the live video. |
| 7 Apply |  | Click to apply the modified settings. |
| 8 Cancel |  | Click this button if you change your mind and do not want to apply the modified settings. The Privacy mask dialog box then closes and reuses the previous settings. |

Appendix 19

Web Remote Player 2.0

Web Remote Player 2.0 is an IE-based remote application to playback recorded video from remote site with whole new designed user interface.

Follow the steps below to install web remote player 2.0 related components and connect to DVR site.

1. Insert huperVision installation disc in the DVR site server machine and click huperUtility in the autorun window.
2. Click Web Remote Player 2.0 item in the huperUtility window to start installation.
3. After installation, open IE browser on the remote site and type IP address to connect the DVR.
4. The web page will prompt an Information Bar message, click OK to proceed.

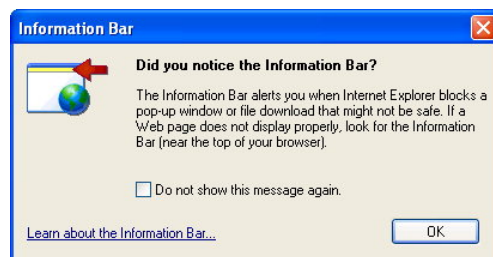

5. Click the Information bar on the IE browser and select Install ActiveX Control... from drop down menu.

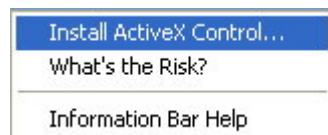

Web Remote Player 2.0 User Interface

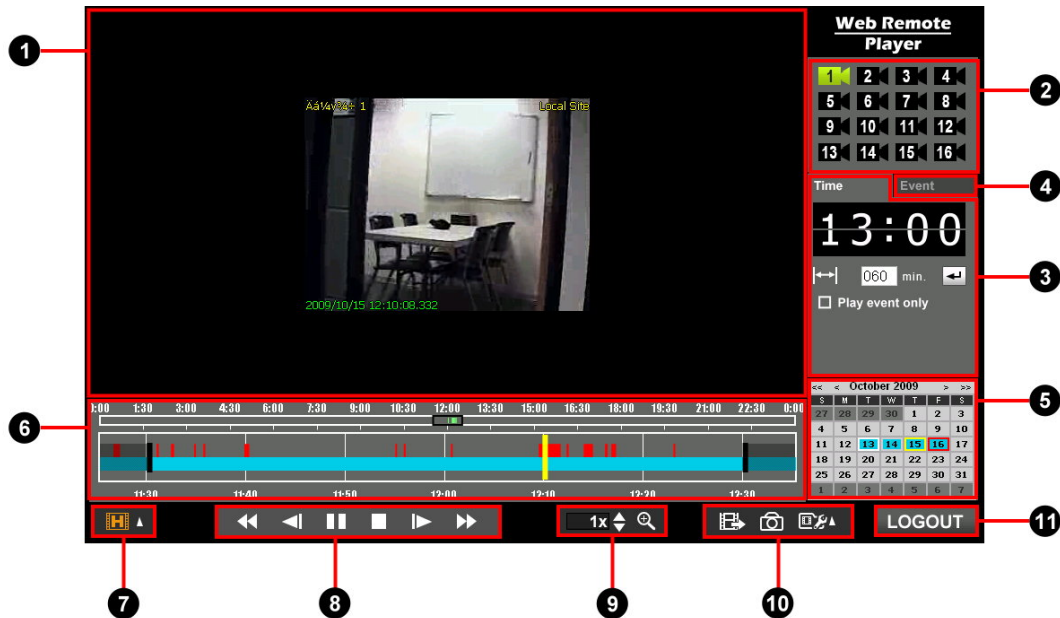

- | | |
|---|--|
| <p>1 Playback area</p> <p>2 Camera Panel</p> <p>3 Time selection mode</p> <p>4 Event selection mode</p> <p>5 Calendar</p> <p>6 Timebar</p> <p>7 Quality control</p> <p>8 Play control panel</p> <p>9 Additional play control panel</p> <p>10 Output panel</p> <p>11 Login / Logout</p> | <p>Display recorded video in this area.</p> <p>Select target camera from this panel.</p> <p>Assign starting time and duration to playback video.</p> <p>Select specified event from list.</p> <p>Select date to playback video.</p> <p>Display video recording data of selected camera in specified data.</p> <p>Select playback quality.</p> <p>Playback function panel: play/pause, stop, previous period, next period, previous frame, next frame.</p> <p>Additional playback functions: playback speed control, zoom in/zoom out.</p> <p>Output functions: Export video, snapshot, set target output folder.</p> <p>Click to login/logout remote site.</p> |
|---|--|

Playback Area





Display video recording data of selected camera at specific date. The display dimension for video is 320x240 or screen fit (using zoom in/zoom out control). The information printed in the video are:

Top-Left	Camera Name	Current selected camera name
Top-Right	Site Name	Current connected DVR site name
Bottom-Left	Date and Time	Current date and time of recorded video

Camera Panel



Camera switch panel and display camera status of connected DVR site. The camera status of icon displayed is listed below:

	Active Camera	Current selected camera
	Available Camera	Current available camera of connected site. Switch camera by clicking the icon and will change to active status.
	Unavailable Camera	Camera which is unavailable for the connected site

Time Selection Mode

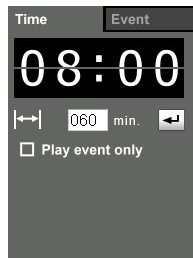

Assign selection area of timebar with starting time and duration. The camera status of icon displayed is listed below:



Starting time

The starting time of selection area of timebar. Click on the hour/minute can flip the clock number one step forward; or you can use mouse wheel to flip the clock forward/backward.

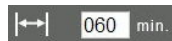

Duration

The selection interval in minutes



Set selection

Click this button to set selection (selection will not be changed if you don't click this button).

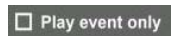

Play event only

Check this option to playback event recording data only in the selection area



Mode switch

Click this tab to switch to event selection mode

Event Selection Mode

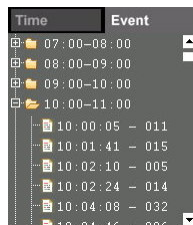





Select event from list to make selection in timebar. The events are grouped by hour. Use “+” / “-“ to fold/unfold the event group and select target item.

Calendar









Select date from calendar to playback video. The calendar date status is listed below:

	Date with recording data	Date contains video recording data of connected remote site.
	Date without recording data	Date contains no video recording data of connected remote site.
	Current date	Red frame around date means today.
	Selected date	Yellow frame around date means date selected for playback.
	Focused date	White frame around date means the current mouse focus location on calendar.

Play Control Panel



Click and select video playback quality. The selected quality icon displayed is listed below:

	Play / Pause	Click to play/pause video.
	Stop	Click to stop playing and set the playback location to the start of the selection area.
	Previous period	Move the playback location 1/10 of selection area backward.
	Next period	Move the playback location 1/10 of selection area forward.
	Previous frame	Move to the previous frame.
	Next frame	Move to the next frame.

Timebar

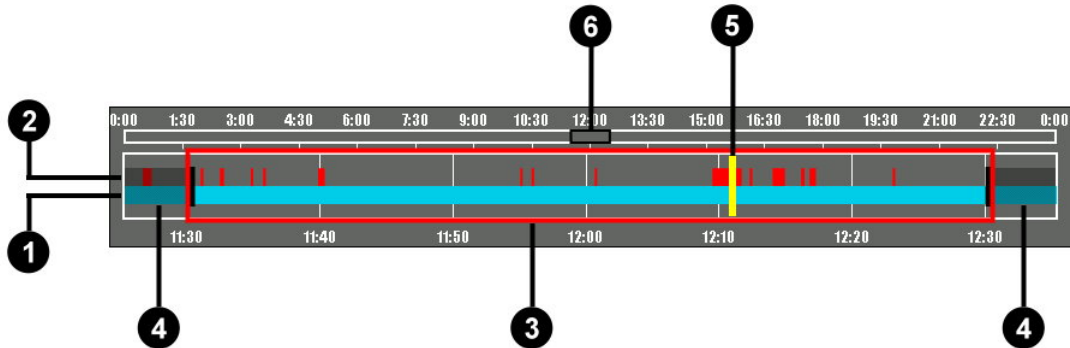

The timebar displays video recording data with selected date and camera. The components of timebar are listed below:

- ① Normal recording The blue color bars on the timebar are the normal recording data.
- ② Event recording The red color bars on the timebar are the event recording data.
- ③ Selection area The area within the red frame is the selected area of timebar.
- ④ Unselected area The area outside the selection area (covered with dark mark) is the unselected area.
- ⑤ Playback pointer The yellow bar is the pointer of current displayed video data.
- ⑥ Selection location The black frame is the time location of selection area located in selected date.

The operations of timebar are listed below:

- Click on location bar or Drag selection area (black frame) This operation is used to keep selection interval and change location.
- Right click on timebar This operation is used to zoom out the timebar display ratio.
- Click on unselected area This operation is used to reset the display ratio of selection area.
- Drag selection area boundary This operation is used to change the start or end position of selection area. The selection interval is also changed..
- Click within selection area or drag playback pointer (yellow bar) This operation is used to change the playback position of current video.

Quality Control



Click and select video playback quality. The selected quality icon displayed is listed below:



High quality

Play video with high streaming quality.



Medium quality

Play video with medium streaming quality.



Low quality

Play video with low streaming quality.

Additional Play Control Panel



Additional playback functions listed below:



Play speed control

Click up/down arrow to increase/decrease playback speed. The range of playback speed is from 1/16X to 16X.



Zoom in / Zoom out

Click to zoom in/zoom out video in the playback area. The video is displayed in 320x240 or fit to playback area.

Output Panel



Output related functions. The function icons are listed below:



Export video

Click to export current selection area of timebar as AVI file.



Snapshot

Click to save current video frame in the playback area as JPEG file.



Folder setting selection

Click to pop up sub items for folder setting.



Assign AVI file location

Click to pop up folder selection dialog to assign path of exported AVI file.



Assign snapshot file location

Click to pop up folder selection dialog to assign path of snapshot file.

Login / Logout

LOGIN

LOGOUT

Click to login/logout remote site. Click the **LOGIN** button will display the login interface in the playback area as below.

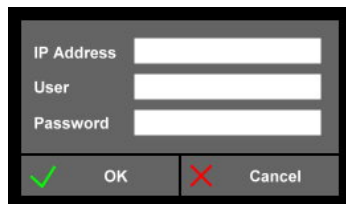
A login dialog box with a dark background and white text. It contains three input fields: 'IP Address', 'User', and 'Password'. Below the fields are two buttons: 'OK' with a green checkmark icon and 'Cancel' with a red 'X' icon.

Enter IP address, user name, password, and click OK button to login to the target remote site. If you press play button from Web Remote, it will pop up Web Remote Player interface and login automatically. Click **LOGOUT** button to disconnect connection.

Appendix 20

SMTP Settings

SMTP related settings allow you to send email through SMTP server if the generated event is needed to be notified. The new SMTP options can use huperVision built-in SMTP server or external servers from other ISP vendors.

You can find the new SMTP settings in the following functions:

- Storage Failure Notification
- Event Notification
- Video Loss Notification

Follow the steps below to find SMTP settings.

- For Storage Failure Notification
 1. Open the Preferences dialog box and click the General tab.
 2. Check the “Storage Failure Notification” in the “Storage for surveillance video recording” group box and then click Options button.
 3. Check “E-mail” and click Options button.
 4. Click the SMTP tab.

- For Event Notification
 1. Open the Preferences dialog box and click the Camera tab.
 2. Check the “Notifications” option in the “Respond to events by” group box and then click Settings... button.
 3. Check the “E-mail” and then click Options button.
 4. Click the SMTP tab.

- For Video Loss Notification
 1. Open the Preferences dialog box and click the Camera tab.
 2. Check the “Notify if video loss” option and then click Settings... button.
 3. Check the “E-mail” and then click Options button.
 4. Click the SMTP tab.

The SMTP Settings

- 1** Default Select this option to use huperVision built-in SMTP server..
- 2** Assigned Select this option to assign external SMTP server.
To setup external SMTP server, you need to assign server name and used port.
- 3** My outgoing server (SMTP) require authentication This option is an extra feature when Assigned option is enabled.
Some SMTP server requires authentication when sending email. Input correct username & password if your server need to authentication.
- 4** POP3 before SMTP This option is enabled when My outgoing server(SMTP) require authentication option is checked.
Some SMTP server will use POP3 to receive email. Input POP3 related information (server name, used port, username & password) for this feature.

Appendix 21

MultipleView

MultipleView is a standalone tool to adjust Live/Player application window size and position for single or multiple instances mode. It also supports large scale display resolution and multiple monitors. With this tool, you can set the Live or Player window size larger than 1024x768 and assigned position within the display area.

Follow the steps below to run and make settings with MultipleView:

1. Run MultipleView tool from **Start >> Programs >> huperVision 1.52 >> Utilities >> MultipleView**.

2. Select Live1 or Player1 from Select instance pull-down menu.

PS: For 32CH version, select Live1/Play1 for first instance; select Live2/Play2 for second instance.

3. Setup monitor and Live/Player program window size from the Display Setup group box. You can select monitor number if using multiple monitors. Program windows size can also be changed if the selected monitor resolution is larger than 1024x768.
4. If the current monitor resolution is larger than 1024x768 and program window is not fit to full screen, you can set Live/Player position in the Position group.
5. To change position, select pre-defined alignment method in pull-down menu (ex. Center). The related top-left/down-right coordinates in the monitor is shown.
6. To customize position, select Custom in pull-down menu. You can set location by typing top-left coordinates or dragging color box in the display area.
7. Click the Apply button to apply to the chosen application.

PS: It will popup warning message if the Live/Player is still working. To apply settings successfully, please close Live/Player and press Apply button again.

The MultipleView dialog box

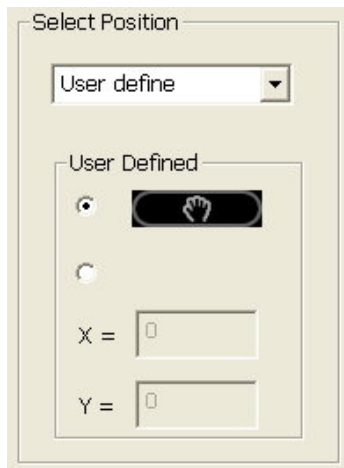
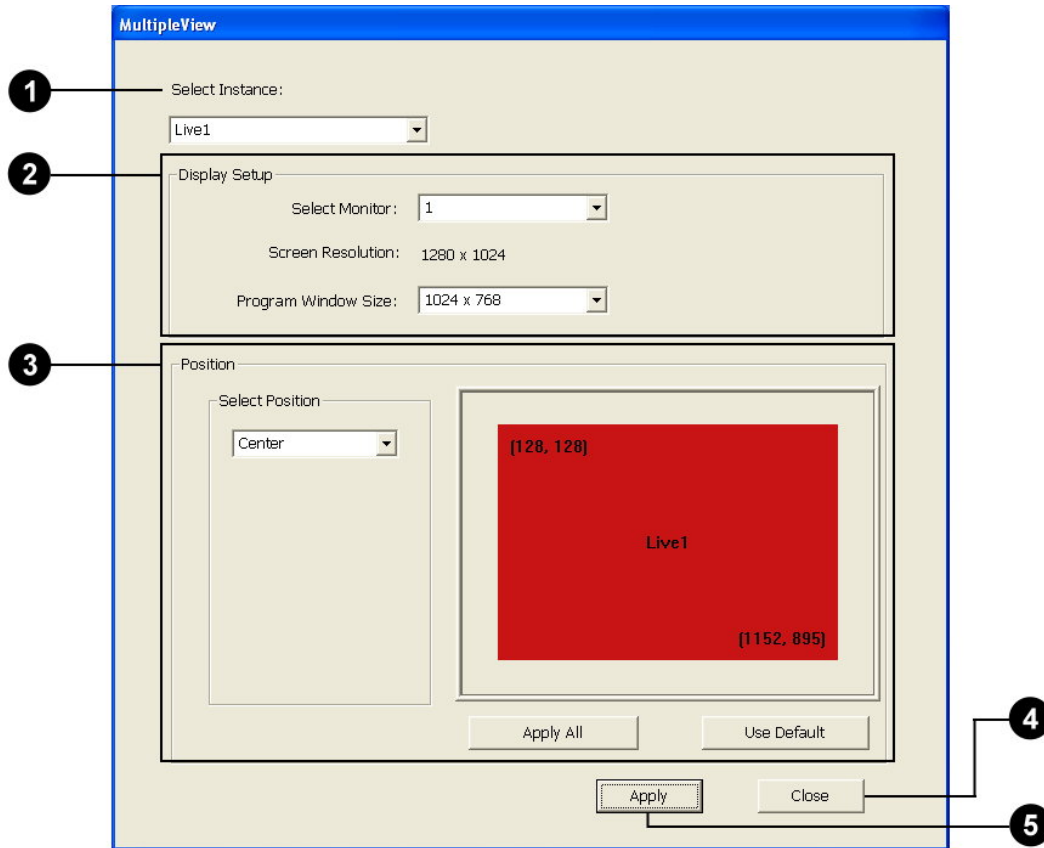

(Settings when select User Defined)

- 1 Select Instance

Select program from list to adjust. In 32CH version, please select Live2 or Player2 to adjust size/location for CH17~CH32.

2 Display Setup

This group contains settings to adjust program window size.

Select Monitor

Select available target monitor to locate selected program..

Screen
Resolution

Display screen resolution for selected monitor.

Program
Window Size

Select available dimension from list to change size.

3 Position

This group contains settings to adjust program window position.

Select Position

Select one of 5 pre-defined alignment method from drop-down menu or select User define to customize position. Default is Top-Left.

Position display
area

This area displays Live/Player program window coordinates (top-left and bottom-right) within selected monitor. Live uses RED rectangle block and Player uses BLUE.

(User Define)



Press this button to change position by dragging rectangle lock within position display area. The coordinates are also changed after dragging block.

(User Define)
Coordinates

Change position by direct input Top-Left X, Y coordinates of program window.

4 Apply

Click this button to apply the modified settings.

5 Close

Click this button if you change your mind and do not want to apply the modified settings. The Flame Detection dialog box then closes and reuses the previous settings.